



# A-WING STARFIGHTER™

STAR WARS

ULTIMATE  
COLLECTOR  
SERIES



75275



Booklet available in English on  
Heft in deutscher Sprache erhältlich auf  
Livret disponible en français sur  
Libretto disponibile in italiano su  
Folleto disponible en español en  
如需中文版手册, 请访问  
[LEGO.com/service/buildinginstructions](http://LEGO.com/service/buildinginstructions)

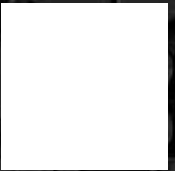



# ABOUT THE LEGO® STAR WARS™ DESIGN TEAM

LEGO® *Star Wars*™ started in 1999 and we have made new models for the product line every year since then. The LEGO *Star Wars* design team consists of 11 model designers and 2 graphic designers. The team is a mix of brand-new designers with fresh new ideas, and experienced LEGO *Star Wars* designers with many models under their belts.

This is an ideal team for creating new, innovative LEGO *Star Wars* models, as well as revising and improving previous LEGO versions of classic and iconic *Star Wars* ships, vehicles and scenes. The focus of our main LEGO *Star Wars* product line is to make cool, fun, and inspiring models for children.

For fans and adults, we have the opportunity to make even bigger, more challenging models with special attention to accuracy and details. These models are fun and exciting to develop, but also a huge challenge! We always do our very best and hope you will enjoy building them.

Happy building!



**Jens Kronvold Frederiksen**  
Creative Director, LEGO® *Star Wars*™

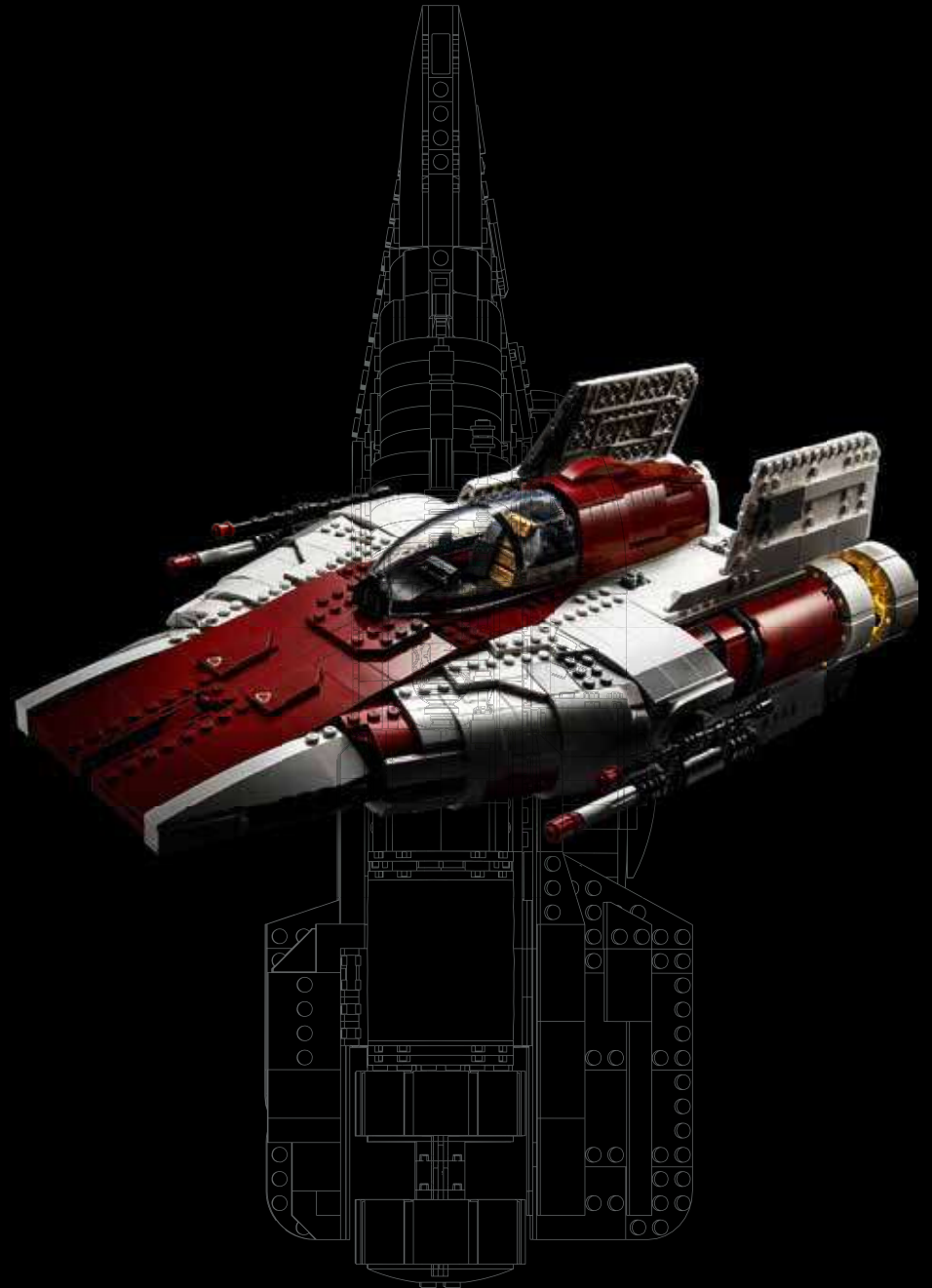



Ralph McQuarrie © & ™ Lucasfilm Ltd.

## ABOUT THE A-WING STARFIGHTER

The A-wing Starfighter you now own is a feat of Rebel resourcefulness: after the Empire rejected the earliest Kuat Systems Engineering's R-22 A-wing model, Rebel cells modified it and turned it into the RZ-1 - a fighter craft even faster than the TIE interceptor, ideal for high-speed strikes and reconnaissance missions. One of the earliest Rebel units to enter these fighters into battle was Phoenix Squadron - an elite group of A-wings

in one of the first larger Rebel collectives - in a fight with Darth Vader™. Later, when the Empire increased production of standard TIE and experimental fighters, Alliance techs reworked the RZ-1 into a fighter that could outrun them all. Lighter, nimbler and harder to handle, the re-engineered RZ-1s blasted their way through the greatest Rebel victory against the Empire: The Battle of Endor™.

Behind the scenes of the film the A-wing Starfighter was one of the two Rebel starfighters designed especially for the *Return of the Jedi* film in 1983. In fact, the name 'A-wing' derives from it being the first of the two designs. Conceived by *Star Wars*™ designer Ralph McQuarrie, the original concept art had blue markings - later changed to red because of the limitations of bluescreen technology at the time.





## LEGO® STAR WARS™: A-WING STARFIGHTER

**Jens Kronvold Frederiksen**  
Creative Director  
LEGO® Star Wars™

**Q:** *The A-wing Starfighter has the markings of a cult classic, having faded in the background after Return of the Jedi only to enjoy a renaissance of sorts in later years. How high was the A-wing on your wish list of models to work on?*

**A:** You could say it's a bit of a 'niche' model, considering how little you see it in the classic Star Wars™ saga. We like to keep an eye on different fan forums and fan-generated media, so we've known for a long time that the A-wing is a fan favourite. We like to give fans what they want, so

this model has been high on our Ultimate Collector Series wish list for many years.

**Q:** *This isn't the first appearance of the A-wing in the LEGO® Star Wars range. How many times has it crossed your desk over the years?*

**A:** I actually worked on the first LEGO A-wing Starfighter, a small play theme unit, around the turn of the millennium – the second year of LEGO Star Wars. Looking back now, that model looks quite funny, very brick-built, far from the sleeker

designs we make today. We've done the A-wing several times as a play theme model, both as an individual and as part of a bigger set. It's a popular one!

**Q:** *How did you and your team come to the decision to make this version of the A-wing now?*

**A:** Partly, it had to do with the fact that a lot of the fanbase really loves models from the classic Star Wars saga. Plus, we were really taken with the awesome dark red and white look of it.

But the main reason behind it was accuracy. We knew that we could make an accurate ship out of existing LEGO pieces except for the cockpit canopy, because it has such a special shape. In the past we simply didn't have an element that could accurately replicate the canopy, but once we got the opportunity to create a special element and get the canopy right, we jumped at the chance.

**Q:** *For people who may not know, LEGO keeps their range of existing pieces really tight. You don't just get to produce whatever pieces you want for any new model.*

**A:** Exactly. We also know that the fans, especially the grown-up ones, really like seeing existing pieces used in a new and surprising way. We do our best to make our models as accurate as possible, and very often that means looking at existing elements in a completely new light. If we can get around a design

problem with existing pieces, we'd always choose to do that.

**Q: How common is it that you have to hold off working on a model until you can create a missing element from scratch?**

**A:** In the earlier years it was very rare that we'd create new elements for our Ultimate Collector Series models, but we've done it more often in later years. However, our aim is to create the models from existing pieces and show the world that you can basically build anything out of LEGO® bricks, even incredibly elaborate models like these. We really only create a special element when we're facing a big design problem that we just cannot solve within the existing brick range - cockpit canopies are typical design headaches, because they're see-through and you can't just combine a few elements creatively to replicate them.

Cockpit canopies are tricky - and not just for us designers. We know fans can sometimes find it difficult to apply stickers to the canopies. In order to make things easier on everyone, we now include two sets of stickers. People can use one set as a practice run, so to speak, and then have a do-over if they find their first application was not perfect. This is the case with this A-wing set, and any future LEGO Star Wars™ Ultimate Collector Series model with canopy stickers.

**Q: The A-wing is a highly streamlined starfighter, stripped down to its most basic**



James Clyne © & ™ Lucasfilm Ltd.

**combat and speed elements. Was this a challenge for the design team?**

**A:** You're right, it's a rather unusual *Star Wars* model because it doesn't really look that much like a spaceship - it's somewhere between a fighter jet and a race car - and that did pose a challenge. Most of our Ultimate Collector Series models have lots of small details and elements, and here you've got these big streamlined surfaces.

One of our big discussions was around the number of visible studs against the use of flat panels. On Ultimate Collector Series models, you'll always

see quite a lot of studs because we want it to look like a LEGO set. In this model you'll see more flat surfaces than usual, because of the natural look of the A-wing.

**Q: You have a grandson who's very keen on LEGO sets. Will you be building your very own A-wing together?**

**A:** This one may be a bit too challenging for him. Plus, he's a huge LEGO NINJAGO® fan, so I'm still trying to convince him that LEGO *Star Wars* is as cool as NINJAGO. Maybe the A-wing will do the trick!

# MEET THE MODEL DESIGNER

Hans Burkhard Schlömer,  
Designer, LEGO® Star Wars™

**Q:** *The A-wing is a classic, yet it's gotten less attention than other rebel fighters over the years. How did it feel to be entrusted with its design?*

**A:** After appearing in *Return of the Jedi*, the A-wing seemed to take a back seat. But there's so much to it! It's the fastest starfighter in the rebel fleet, excelling in reconnaissance missions or as an interceptor. As a fan of the classic LucasArts

*Star Wars*™ computer games and an A-wing pilot myself, creating the Ultimate Collector Series version of this incredibly cool classic design was a dream come true.

**Q:** *What makes this model stand out among other LEGO® Star Wars builds?*

**A:** LEGO A-wings have always been a regular sight in toy stores, but this is the first time this ship

gets the Ultimate Collector Series hero model treatment. Only an extremely select few designs are chosen to receive this honour – it took the A-wing over 20 years from the start of LEGO *Star Wars*.

**Q:** *The A-wing has taken different shapes through the course of its history: the original R-22 prototype, the RZ-1 from Return of the Jedi, and the improved R-22. Which design elements did you bring into the LEGO model from these different iterations?*

**A:** The LEGO *Star Wars* team wanted to go for the most iconic version of the A-wing, which in our opinion is the one you see in *Return of the Jedi*. In fact, the dark red details on this model show that this is a very particular A-wing indeed: this is the fighter that crashes into the bridge of the Super Star Destroyer *Executor* during the Battle of Endor™, leading to its collision with the second Death Star™.

**Q:** *Did you have a particular starting point when designing the A-wing? Does size or brick count matter?*

**A:** Since the A-wing is just slightly bigger than a sports car, the model could not be in scale with other Ultimate sets. The size of the pilot seat should give you a good idea of the fighter's real dimensions. LEGO windscreen elements usually only come in increments of 2 studs/units, so the initial question was whether to go with a 6- or 8-wide windscreen. The first version I built, based





on an 8-wide windscreen, was way too big and still wouldn't have featured any more details that a smaller version could. Brick count doesn't really matter - only making the best model possible does.

**Q:** *The A-wing is an extremely lean craft - little more than a cockpit with two engines. However, Ultimate Collector Series models are usually very rich in detail. As the designer of the model, are there any features and details you're especially proud of?*

**A:** Aside from the building techniques required to design and attach the curved hull sections, there are two notable details I'd like to highlight: there are curved openings at the back of the A-wing. On the studio model, they turned out to be air intakes from F-16 fighter jet model kits! I also added rotating guns, because some publications mention them even though I believe there's no screen evidence of them. It's a nice added feature.

**Q:** *When designing this as well as other Star Wars™ models, how do you imagine people interacting with your work - as something to admire, or something to play with?*

**A:** Appreciation of LEGO® Star Wars sets takes many forms, from playing with a model to collectors keeping the box sealed. The ideal for Ultimate Collector Series sets is of course for them to be built and eventually displayed proudly on a shelf or desk. You can always pick up another box later on for collecting, right?



Star Wars: Return of the Jedi (1983) © & ™ Lucasfilm Ltd.



Wesley Seeds Ilm paints A-wing model for Star Wars: Return of the Jedi (1983) © & ™ Lucasfilm Ltd.



[LEGO.com/brickseparator](https://www.lego.com/brickseparator)

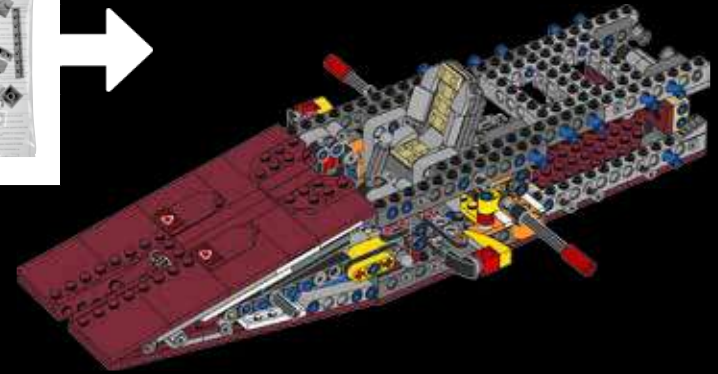
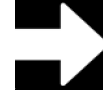
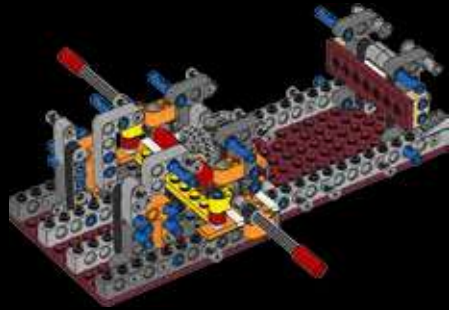

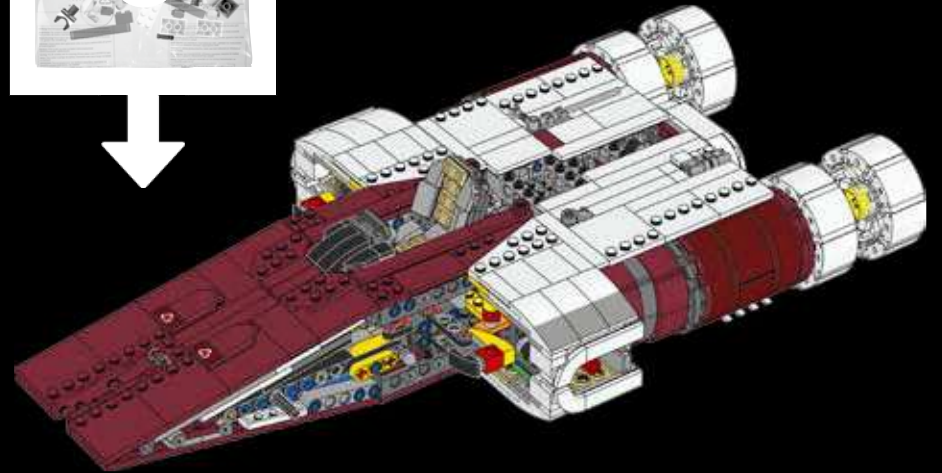
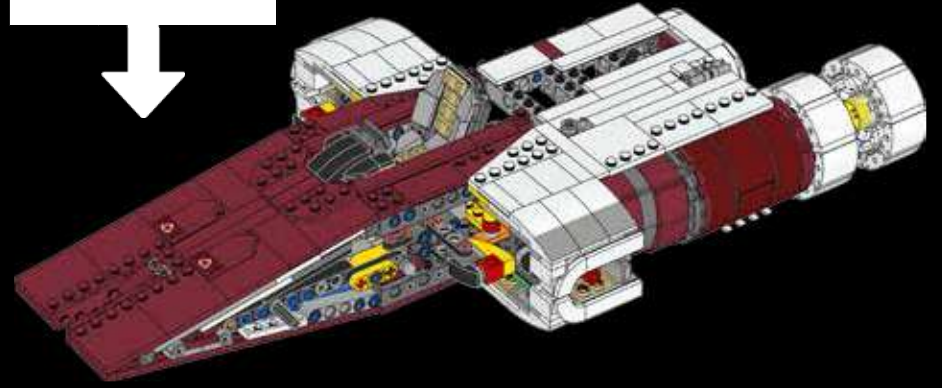
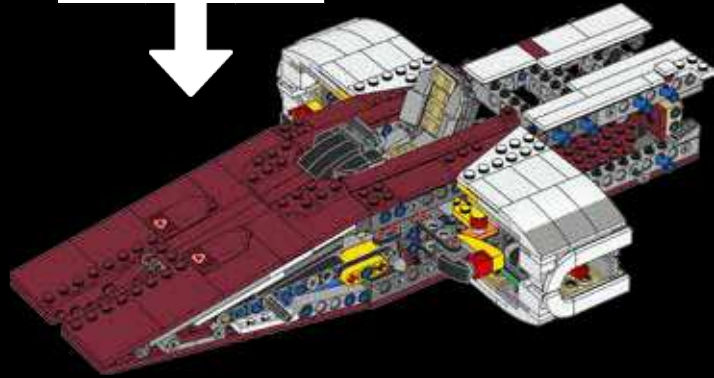



7

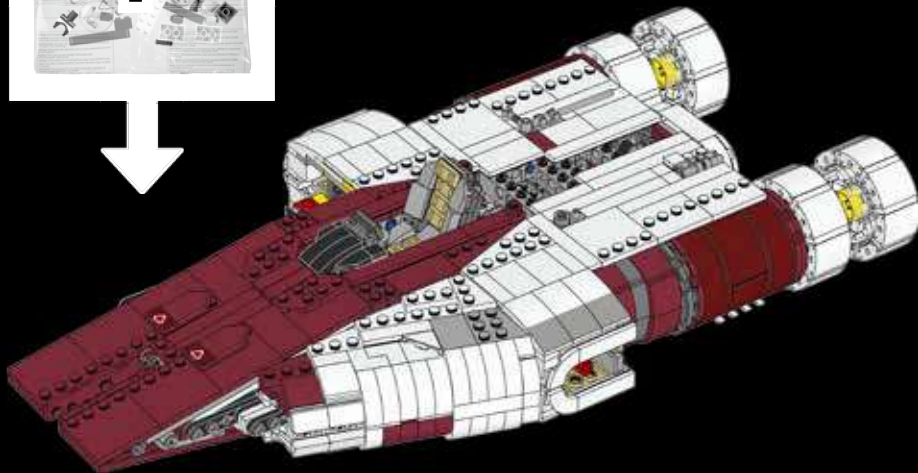

8

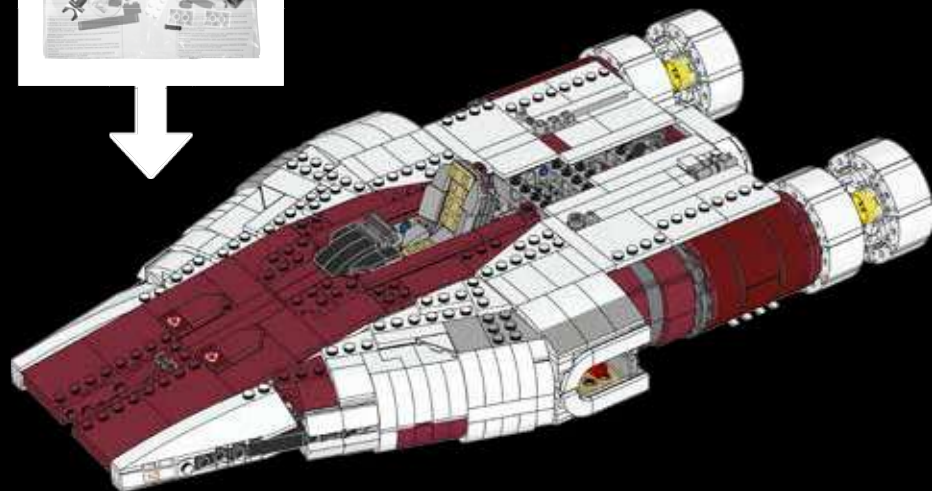

9

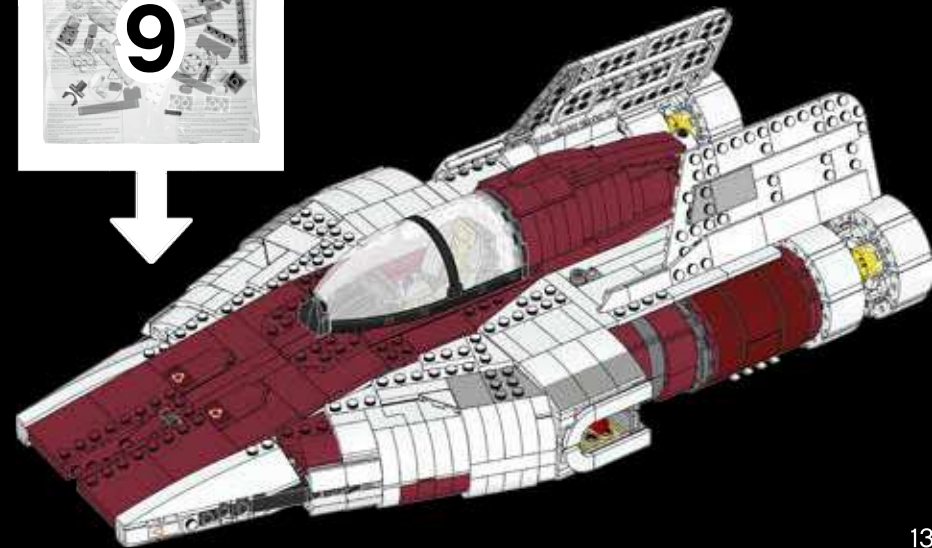

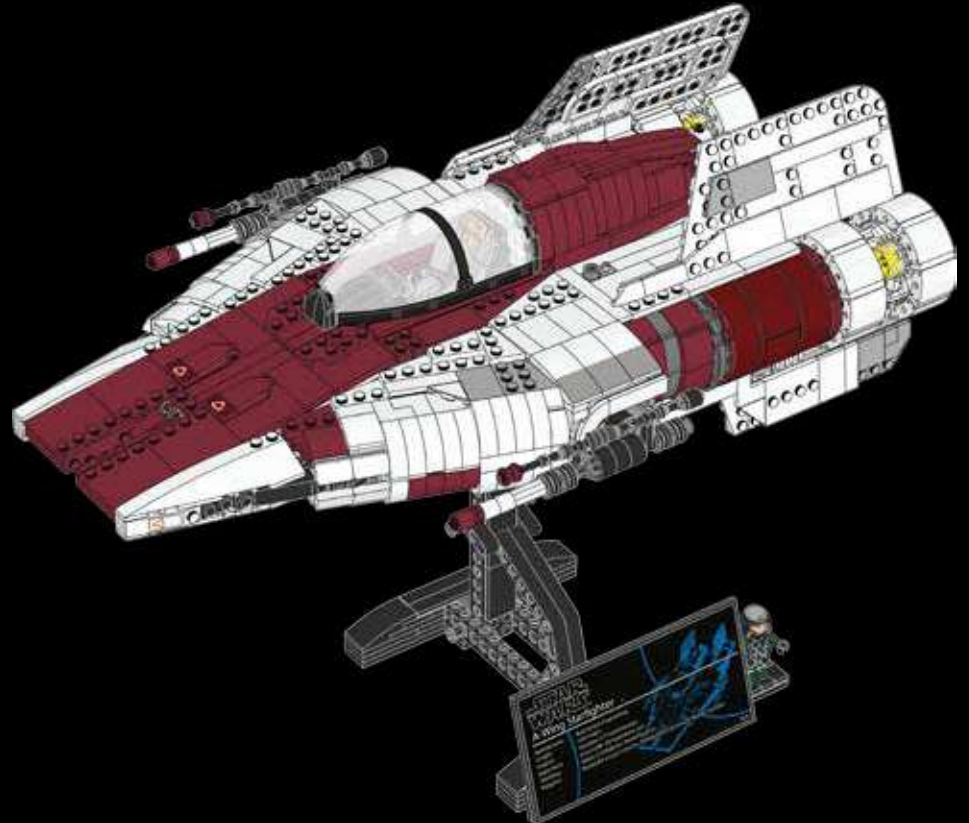

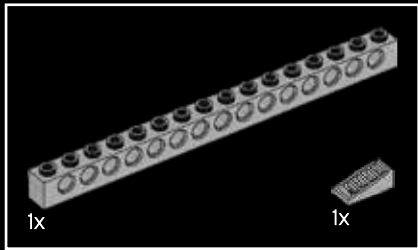
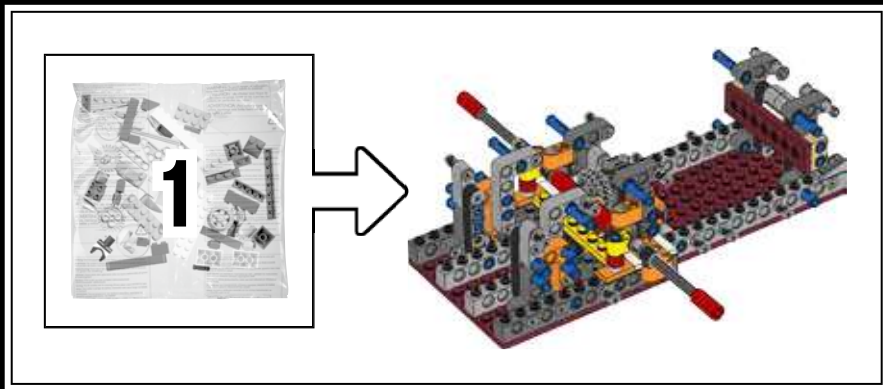

1

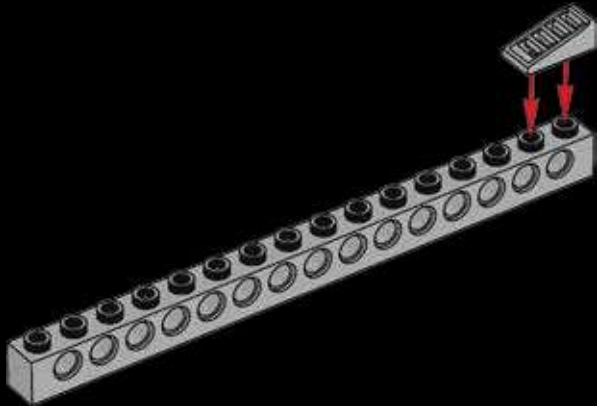

2

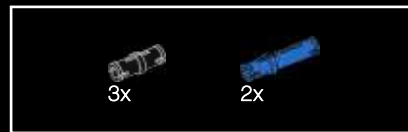
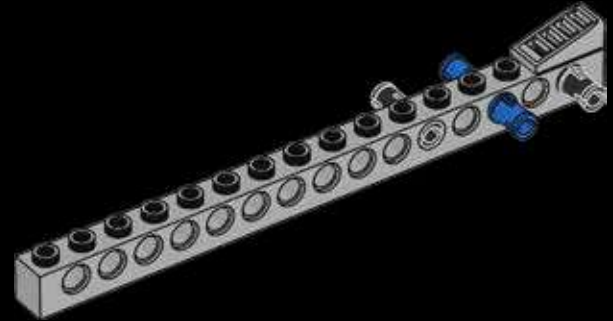

3



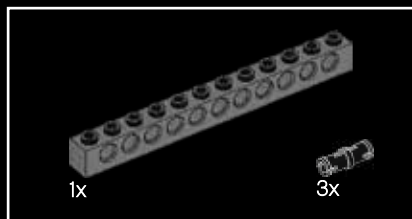

4

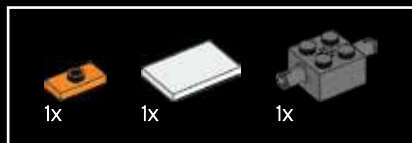
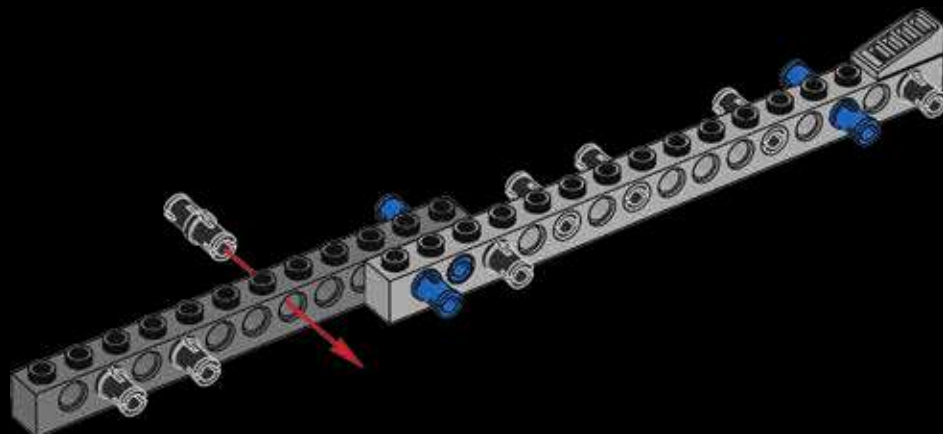

5

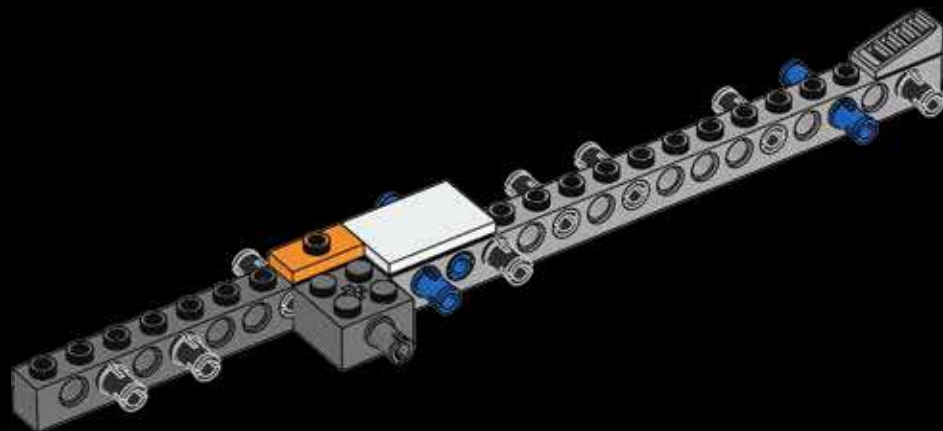



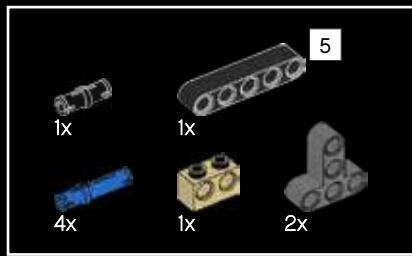

6

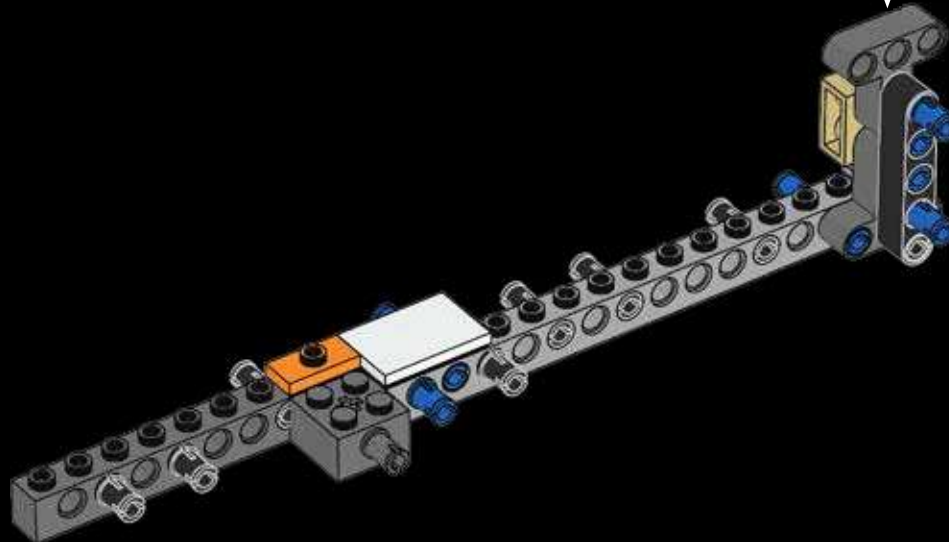
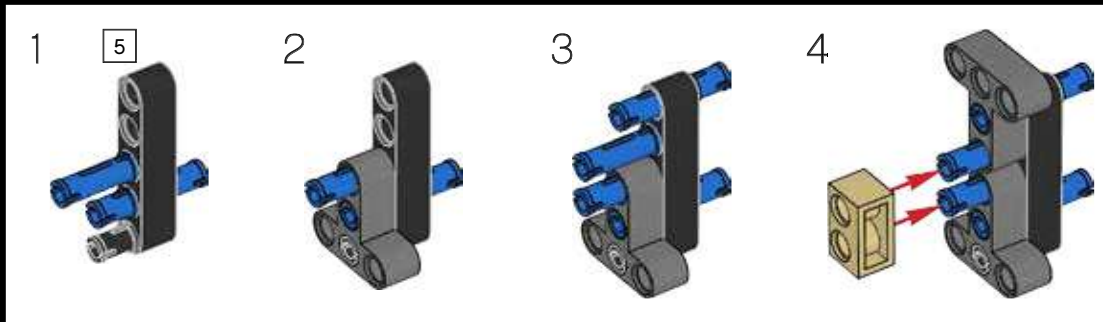

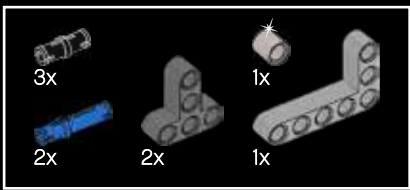

7

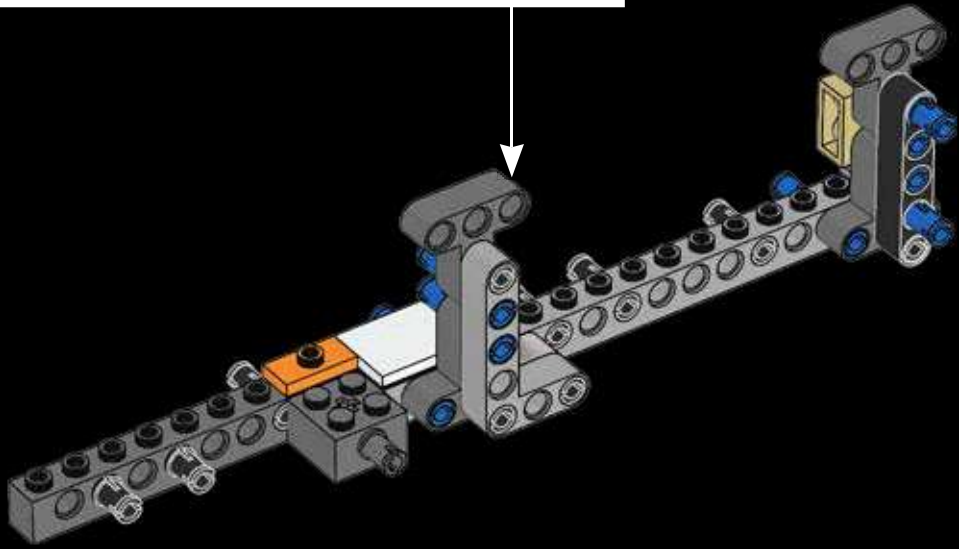
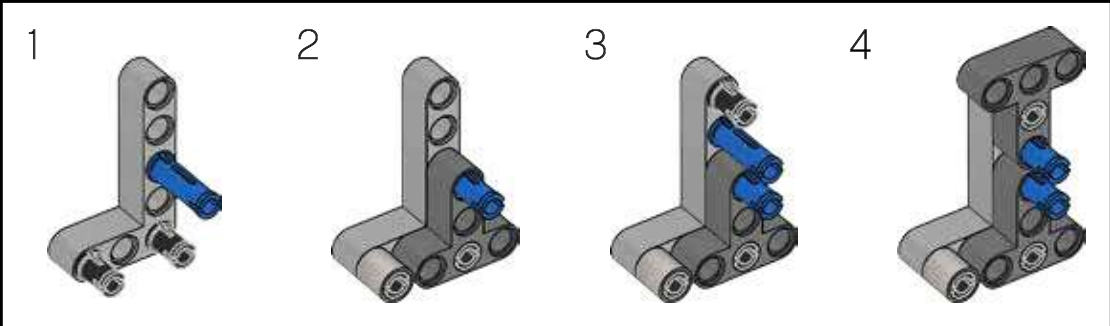

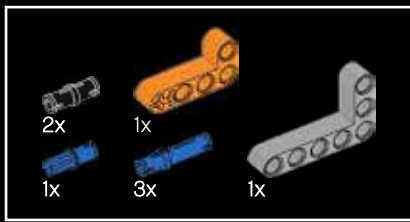

8

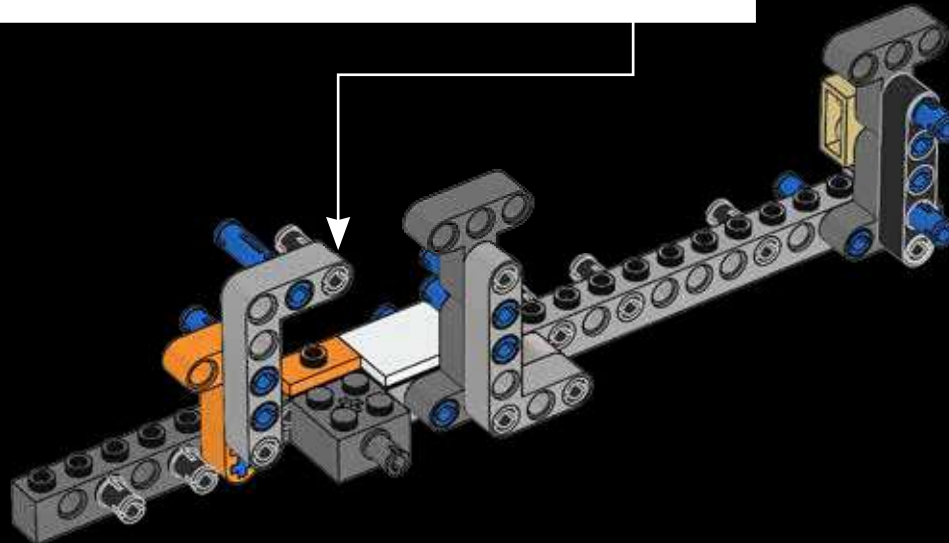
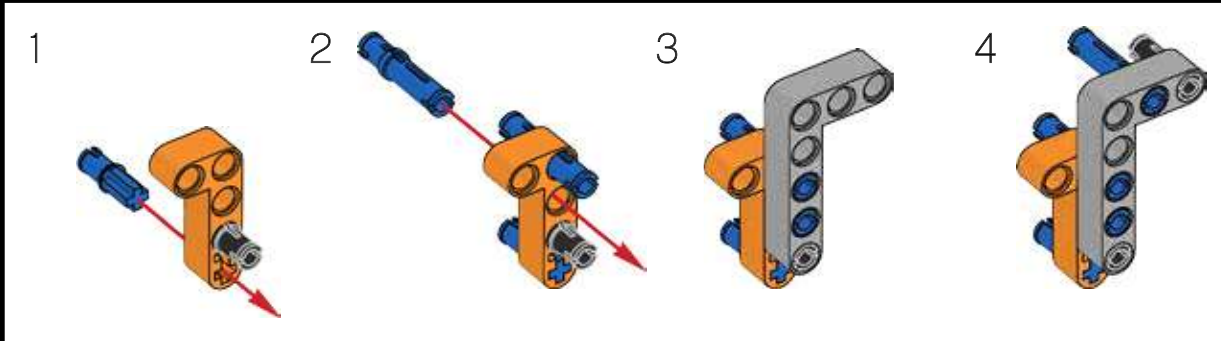



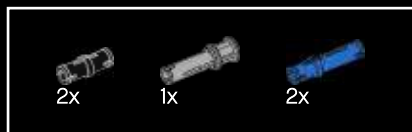

10

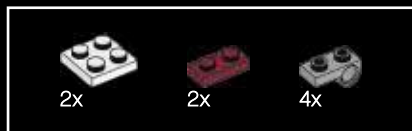
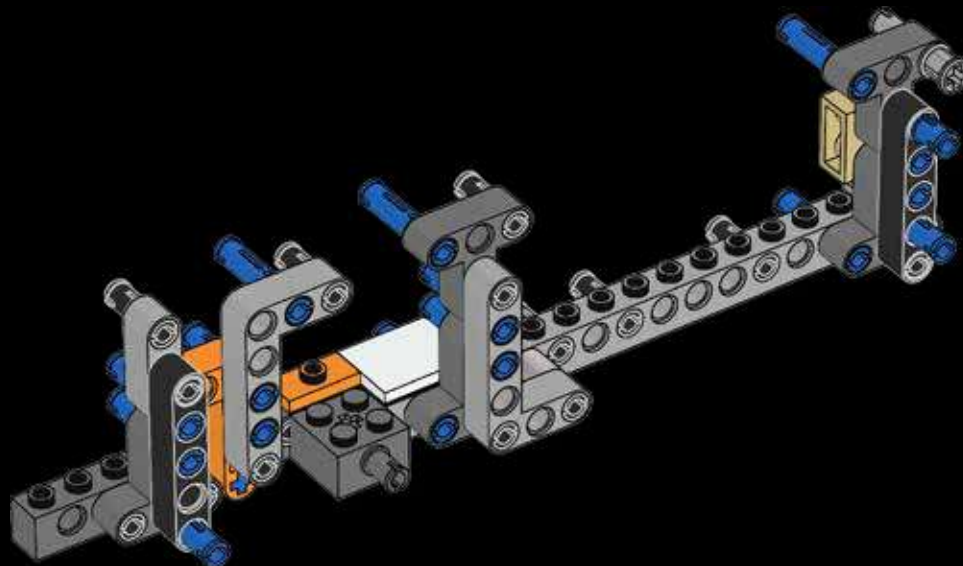

11

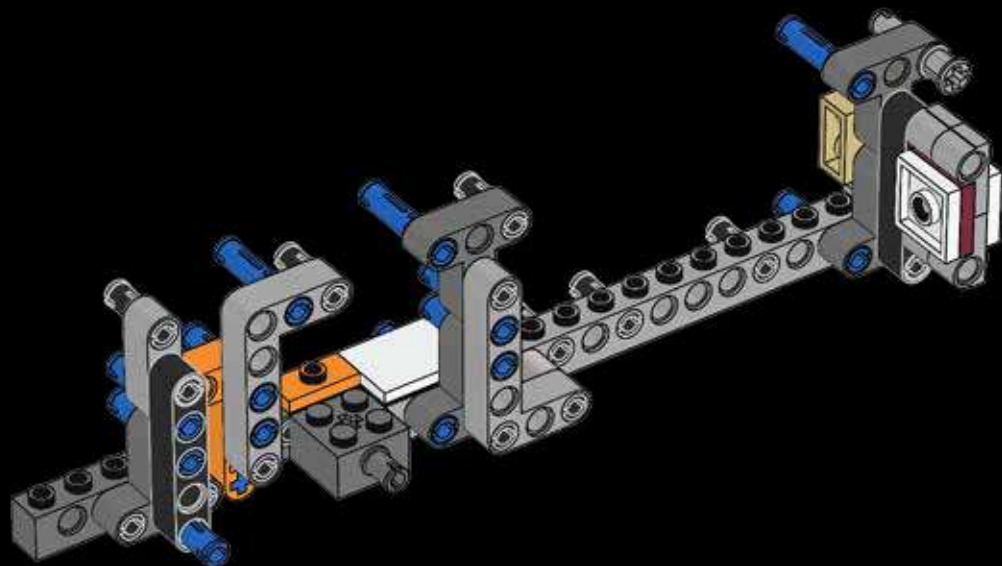
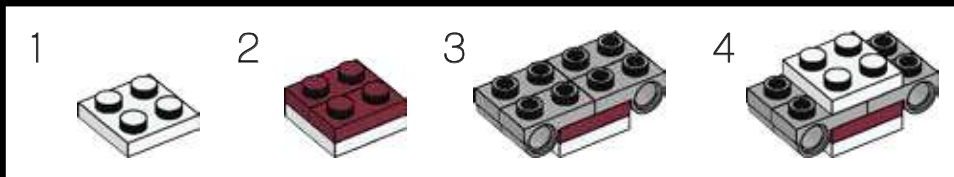

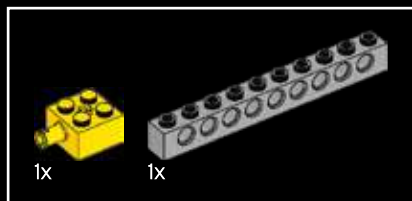

12

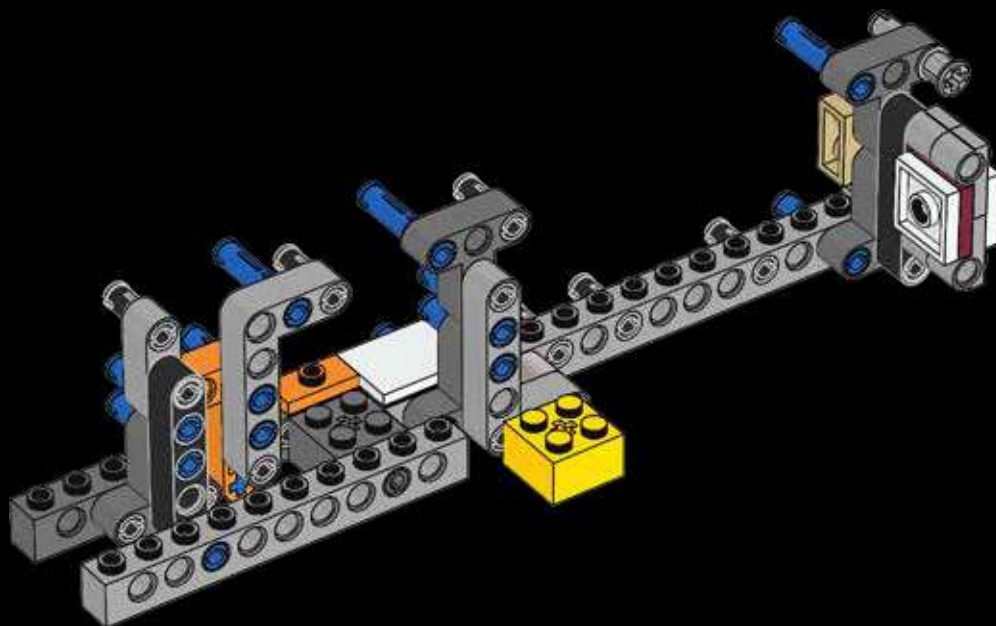

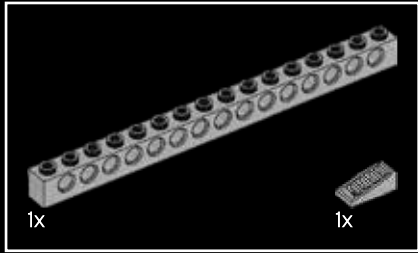
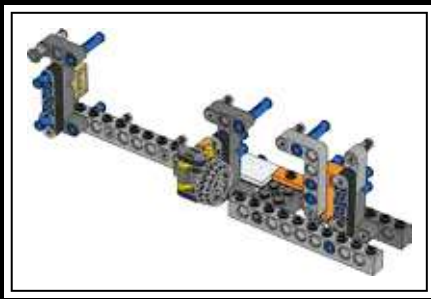

13

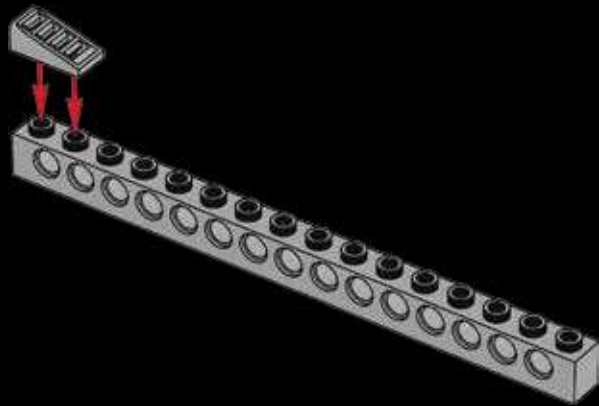

14

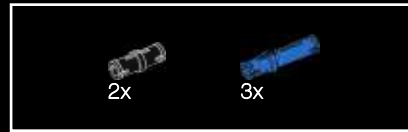
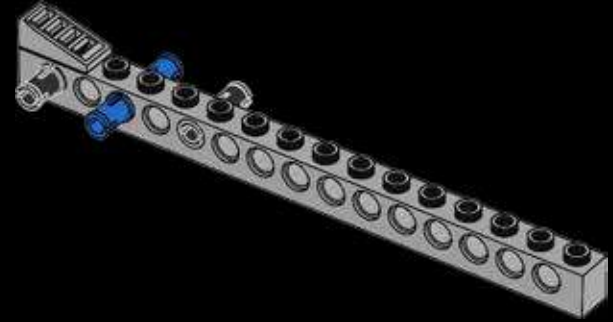

15



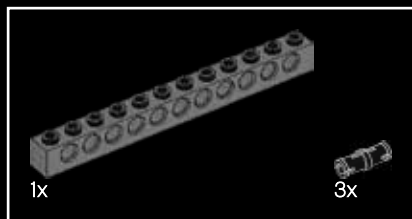

16

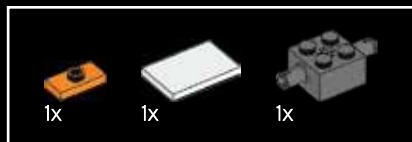
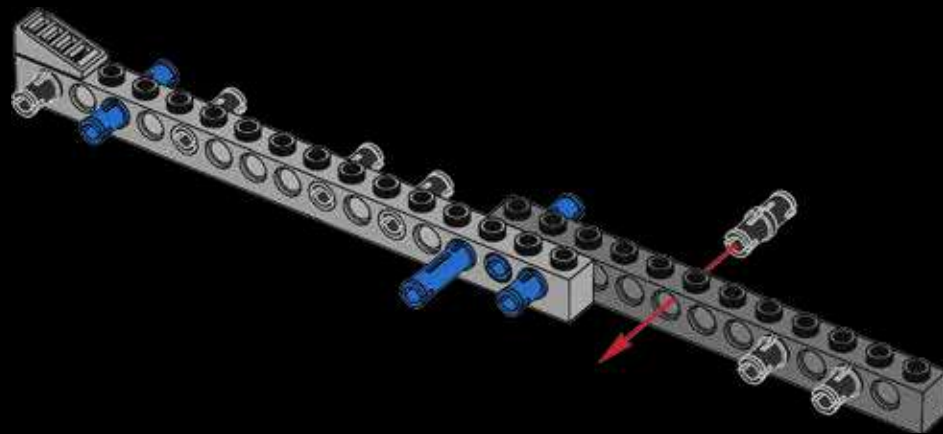

17

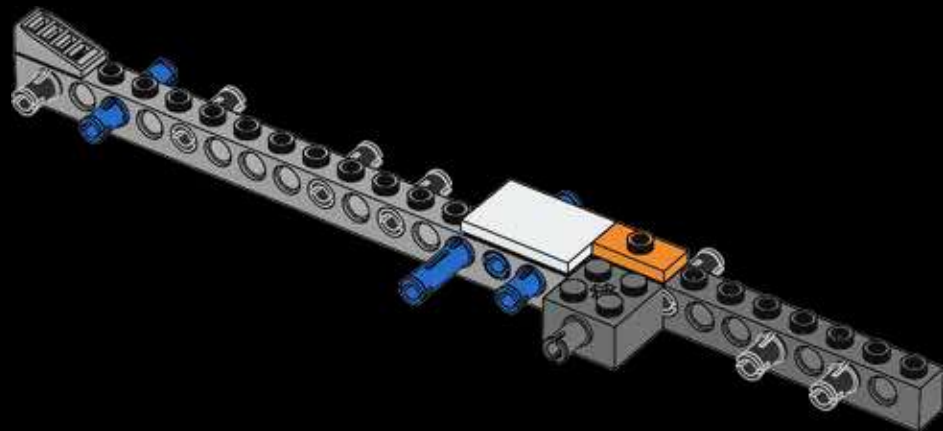





18

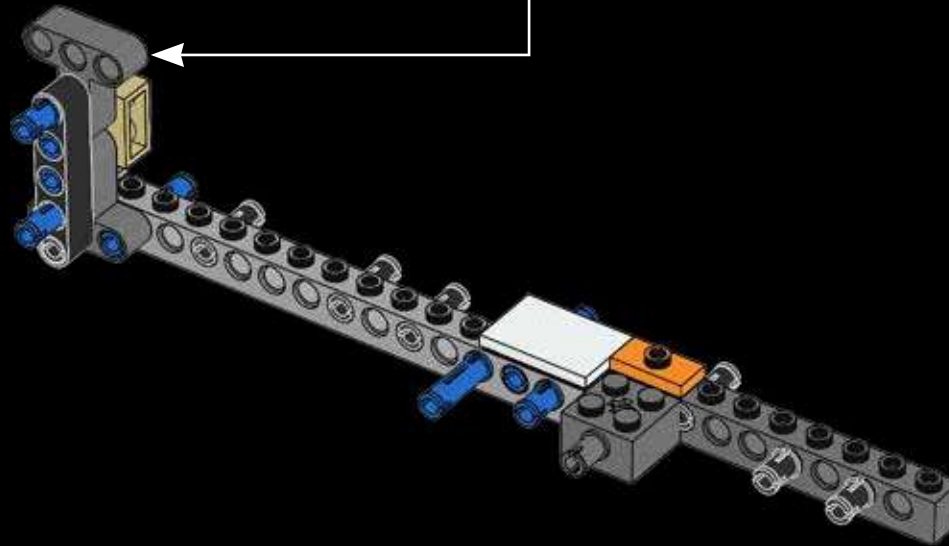
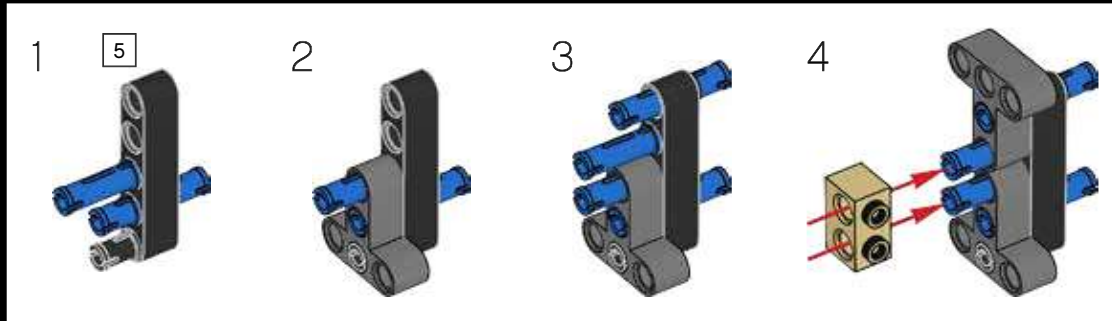

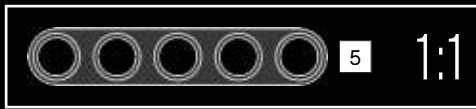
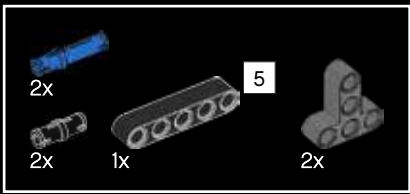

19

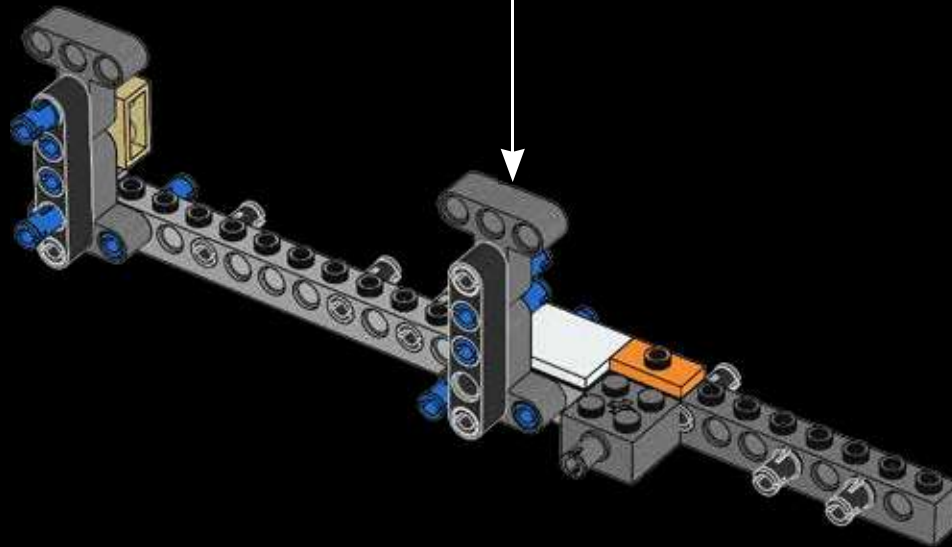
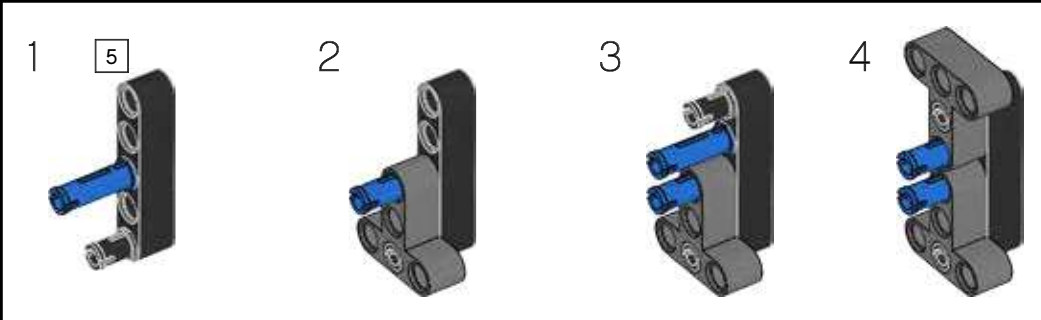

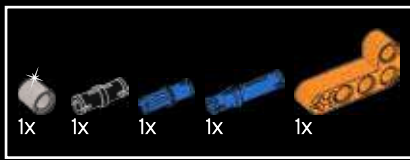

20

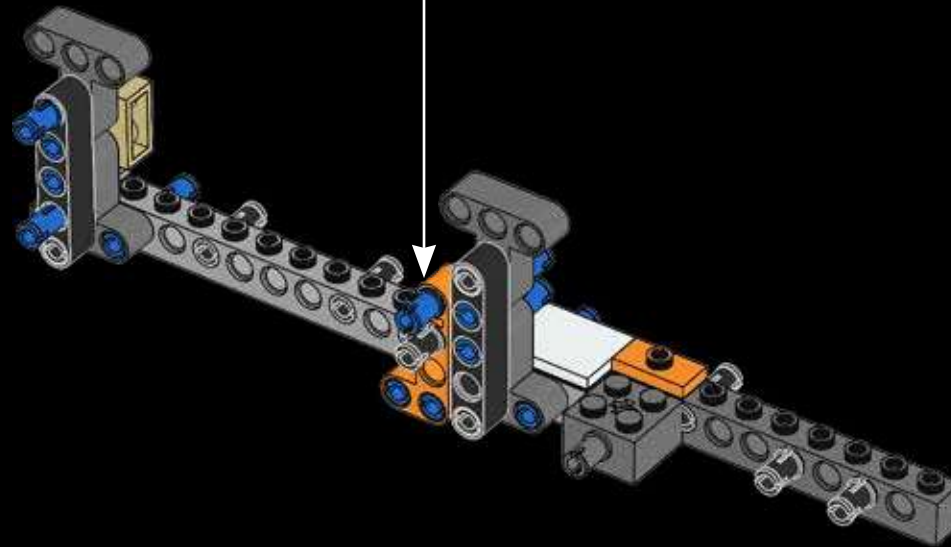
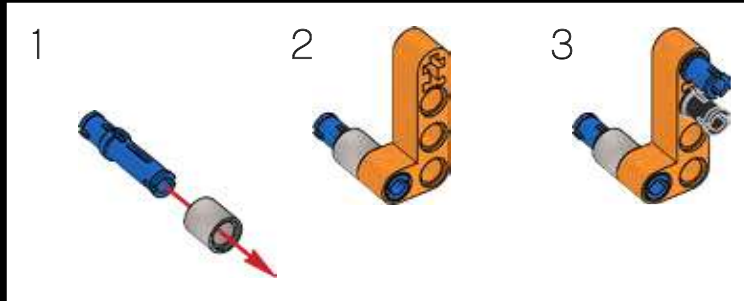

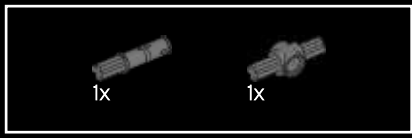

21



22



23



24

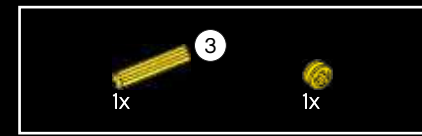
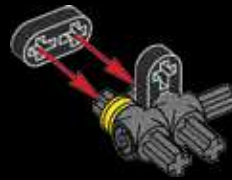

25



26





27

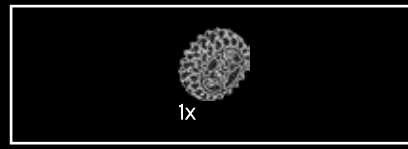

28



29

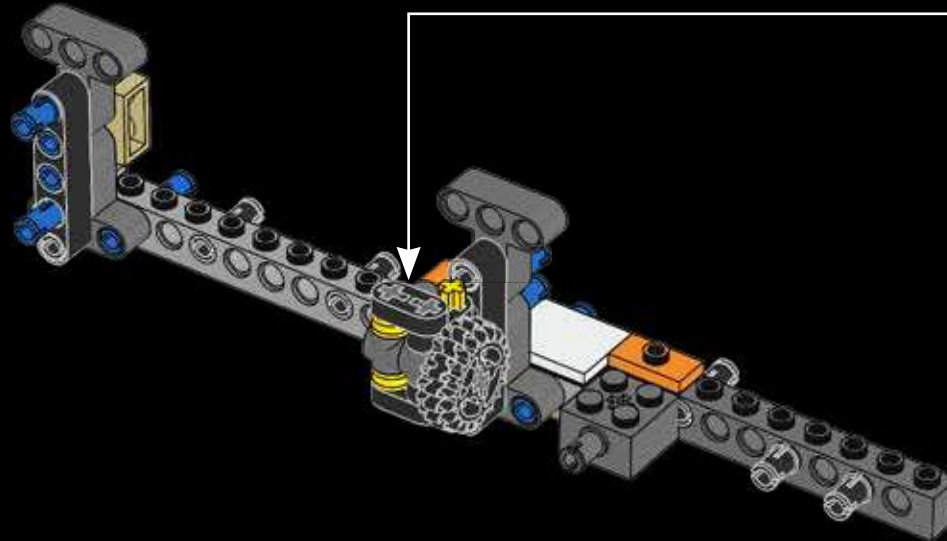

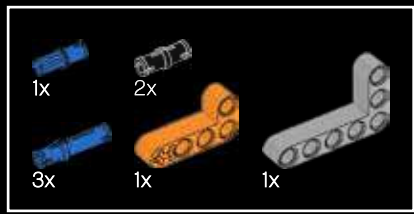

30

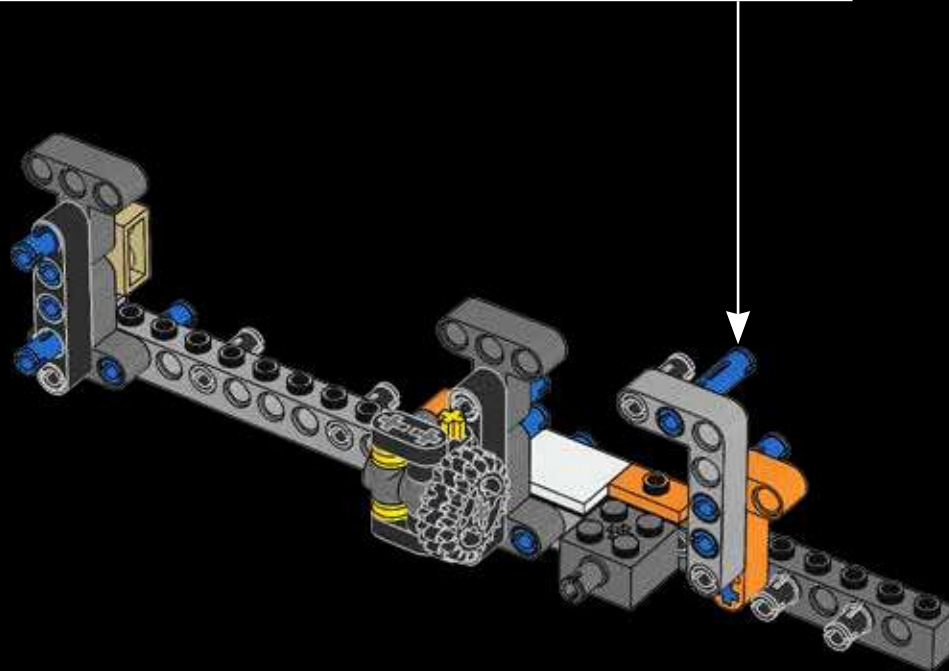
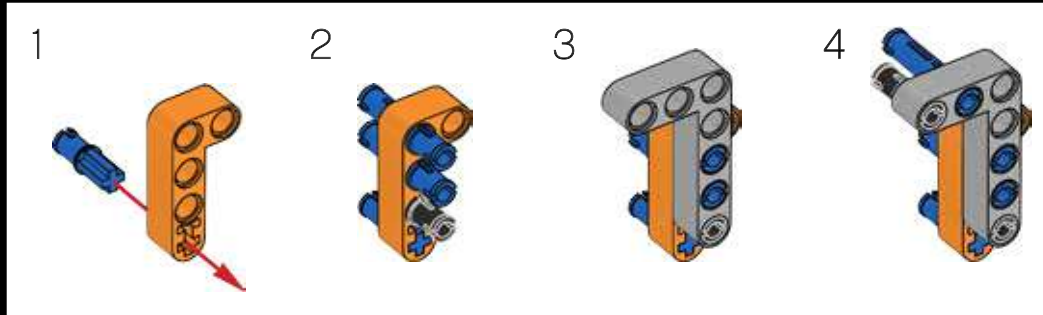

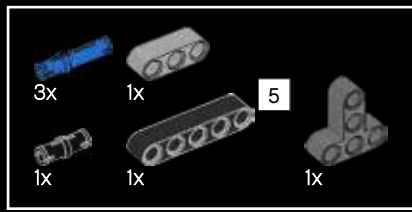

31

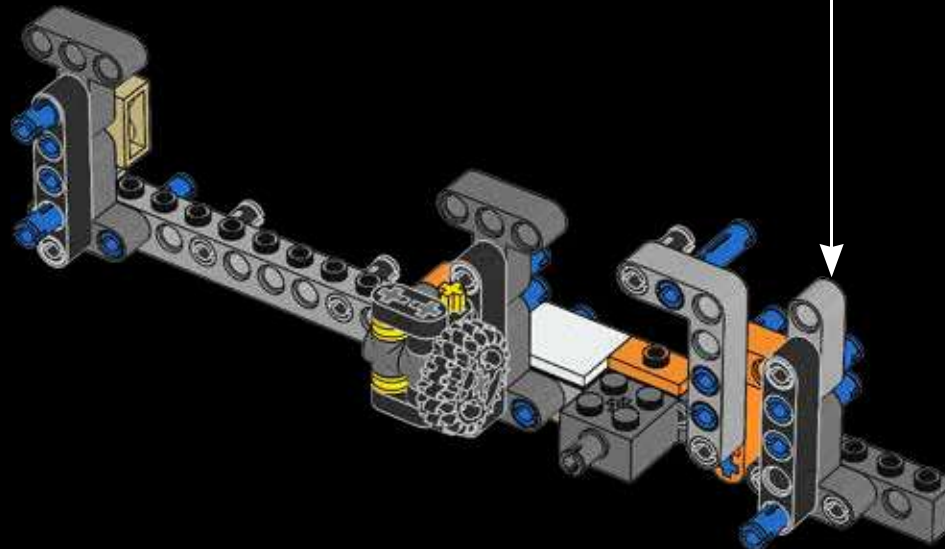
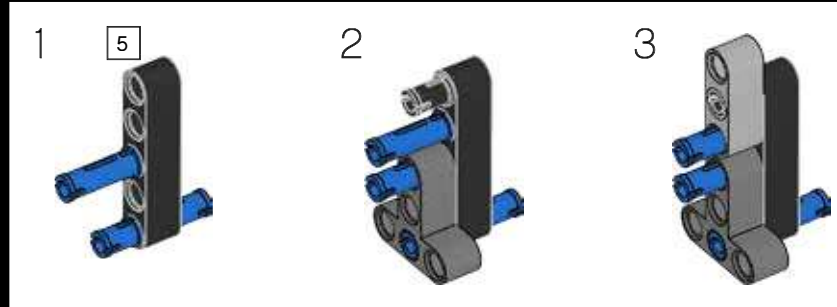





34

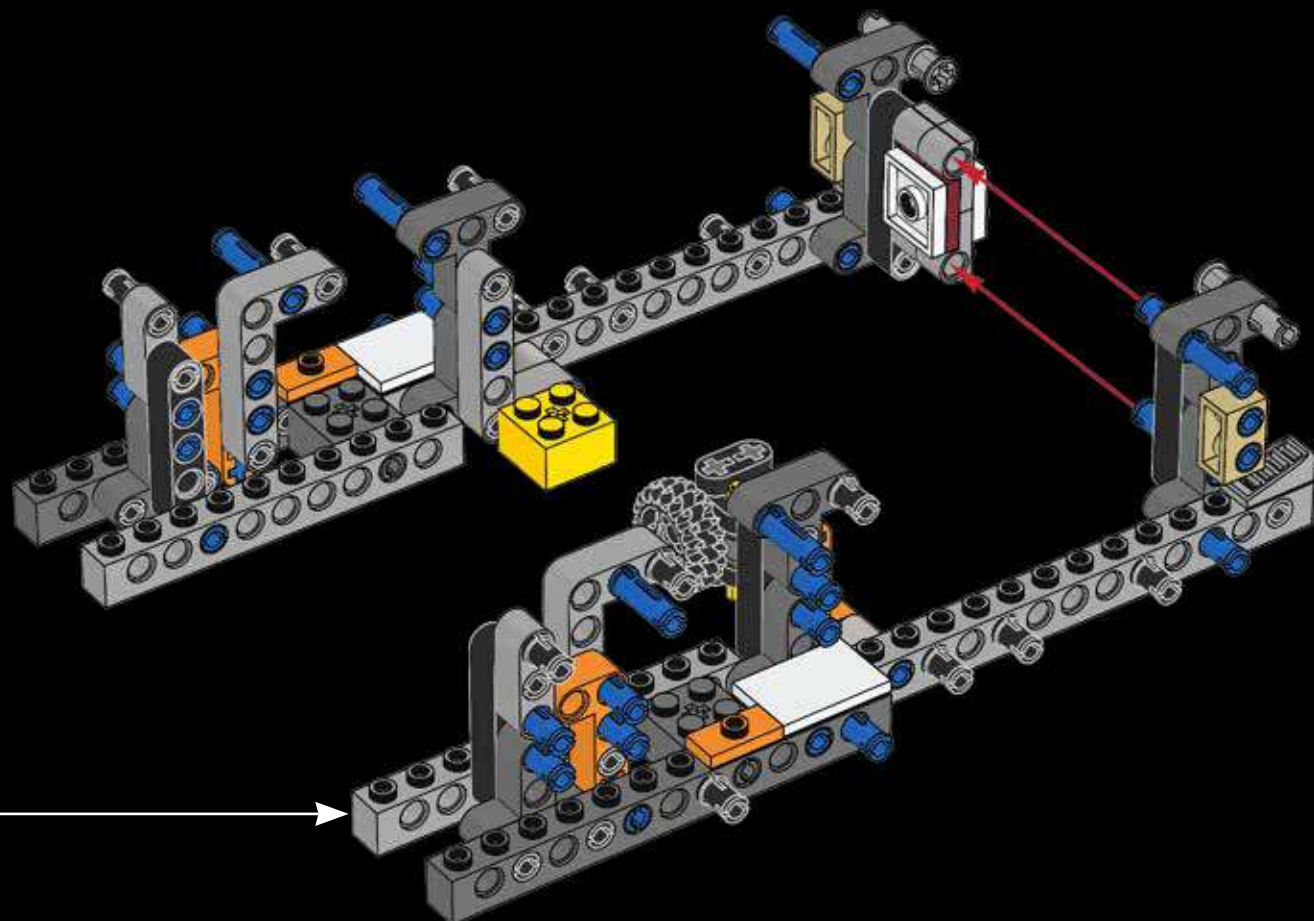



35

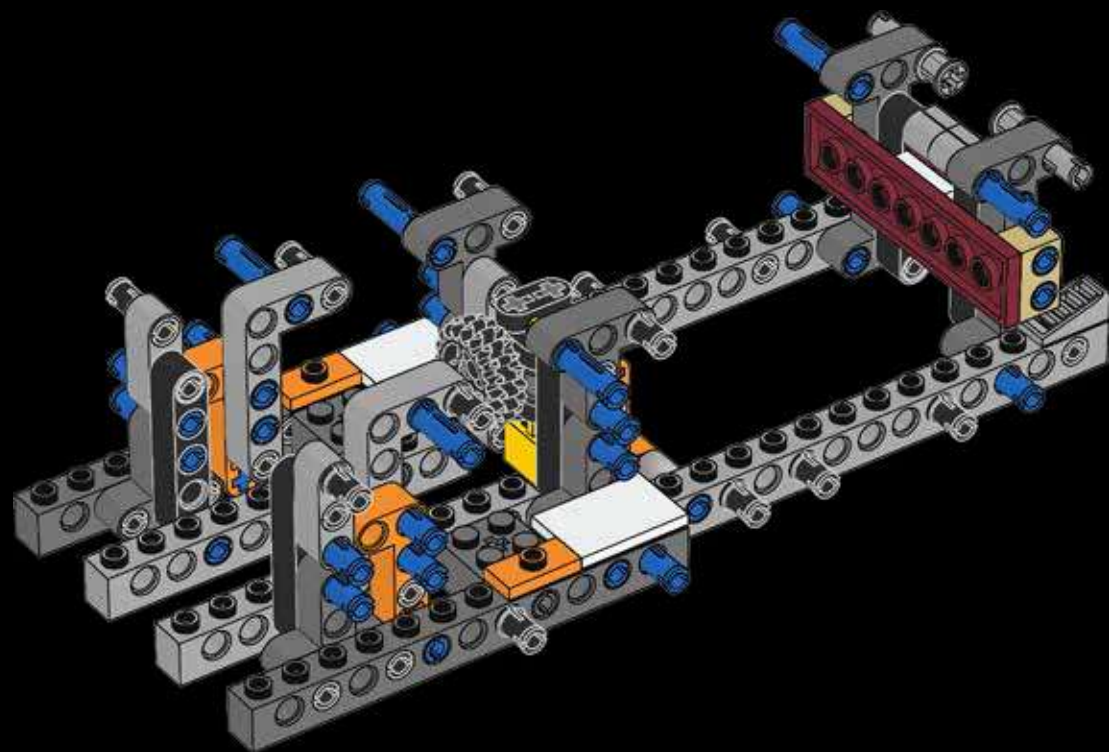



36

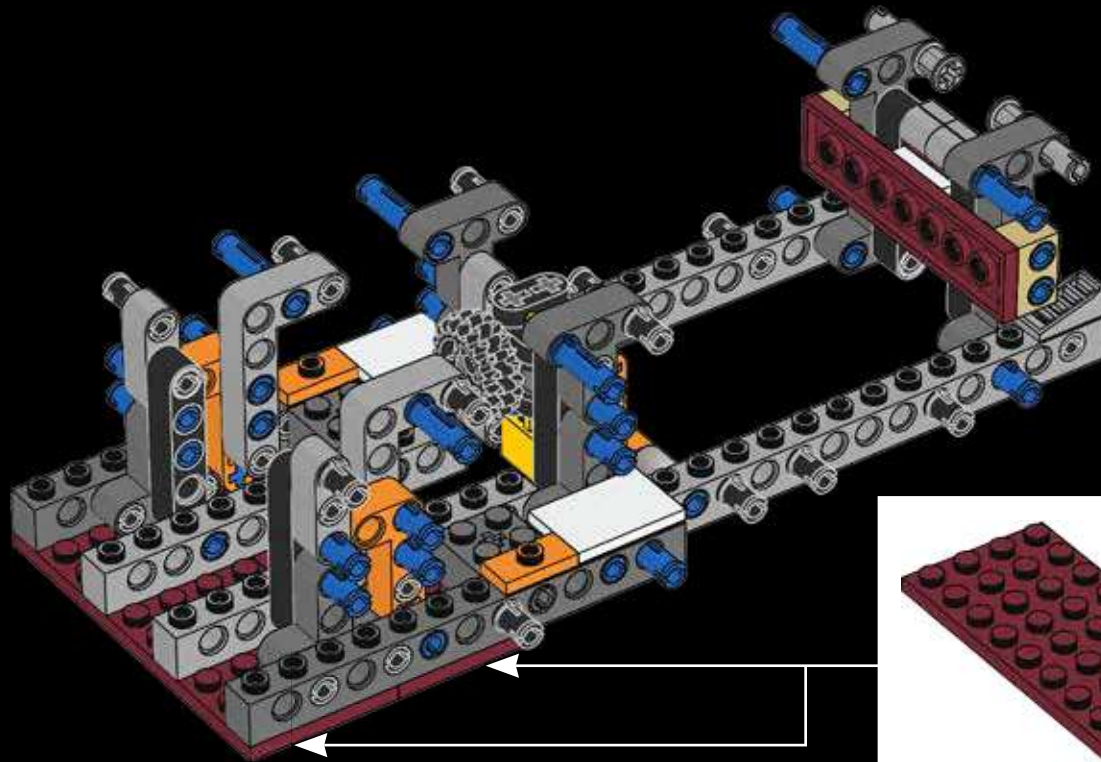

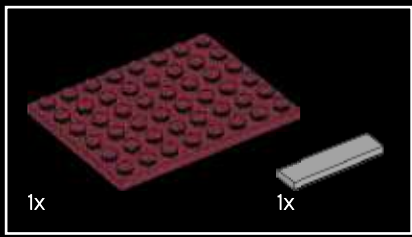

37

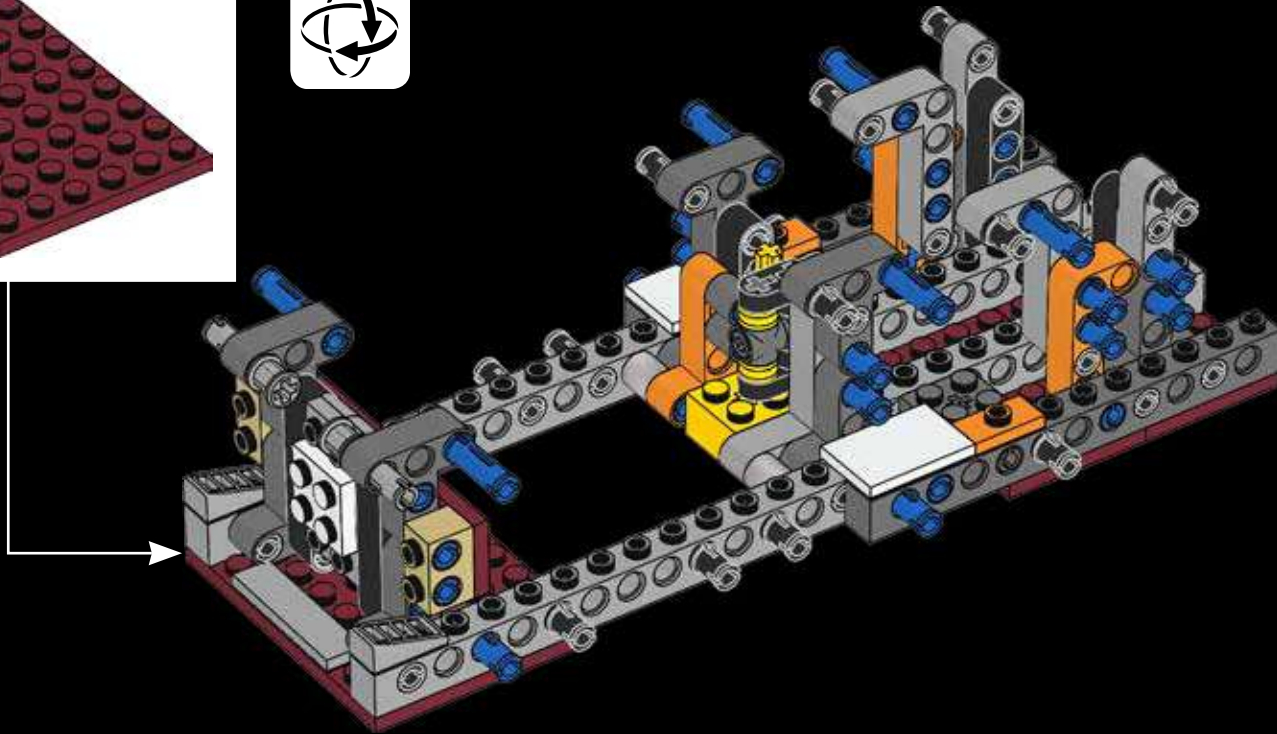

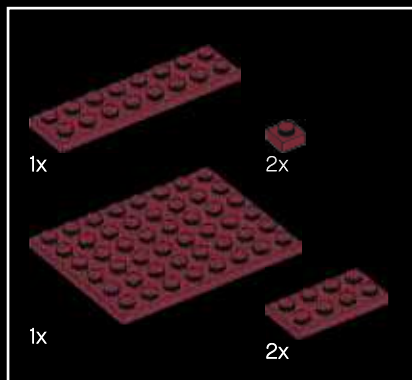

38

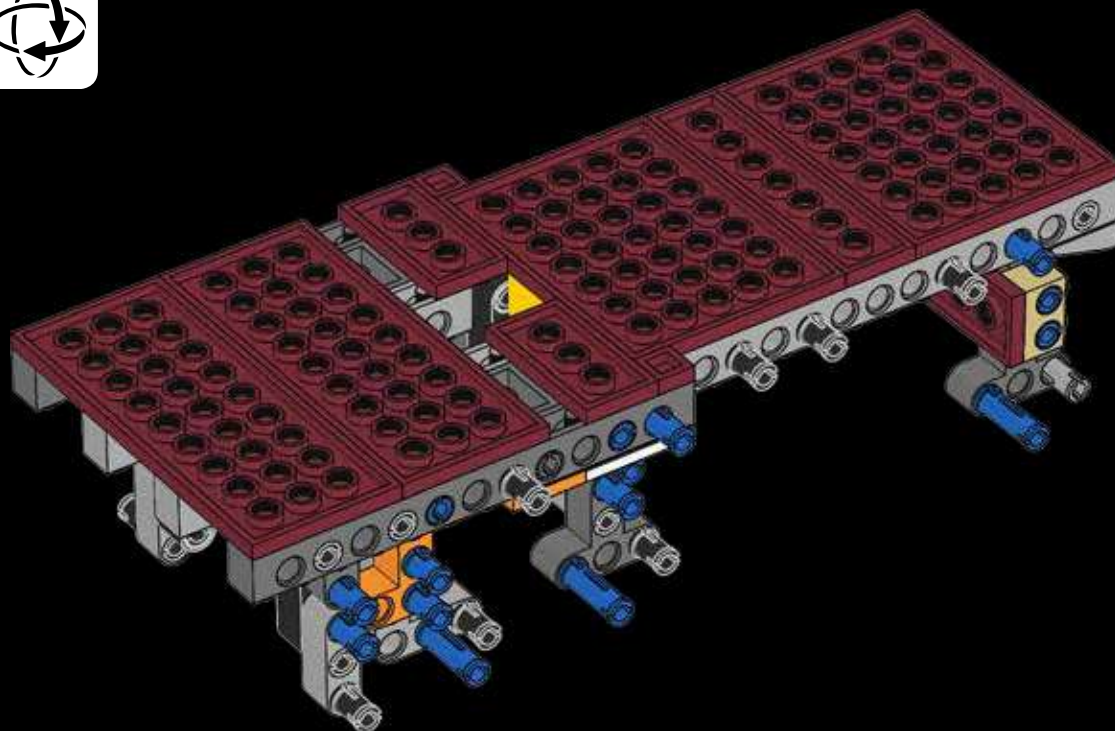

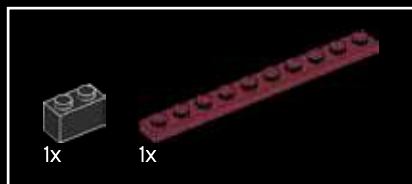

39

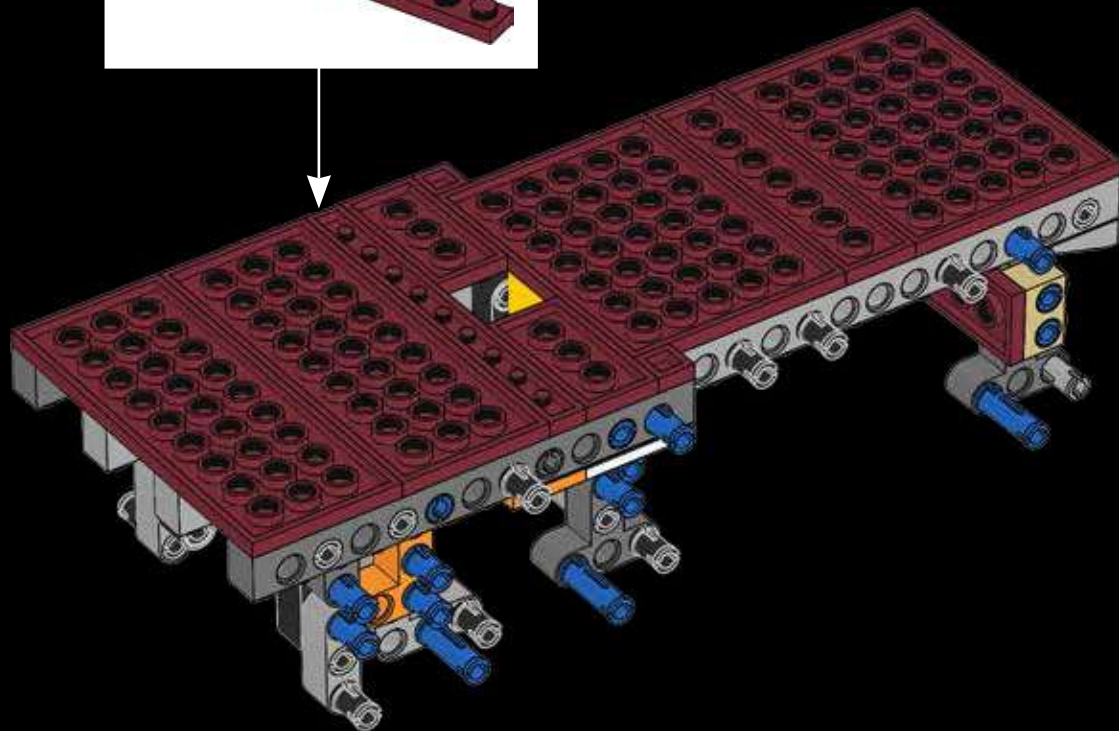
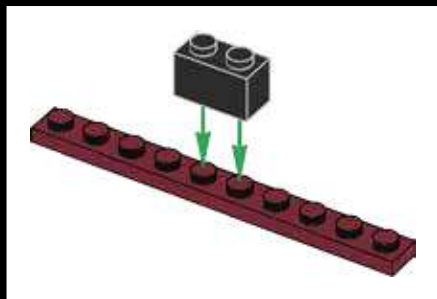

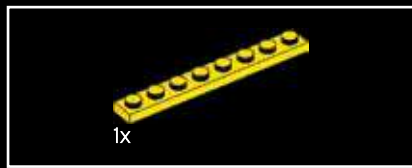

40

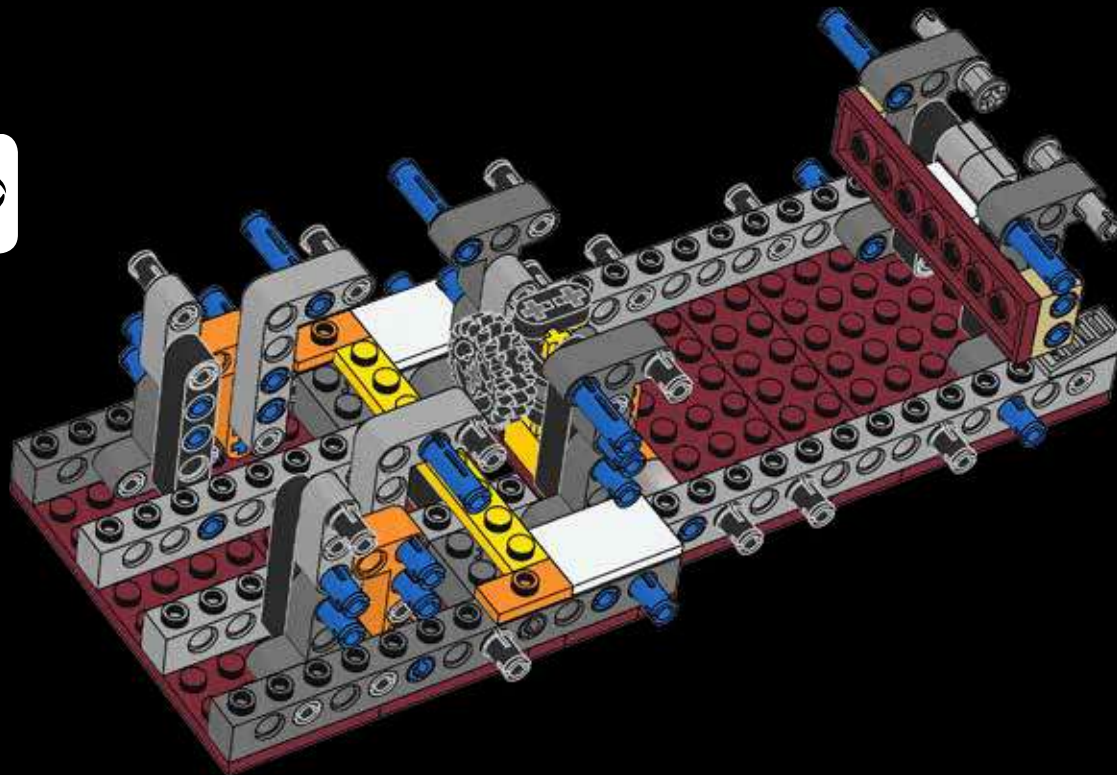



2x



2x

41

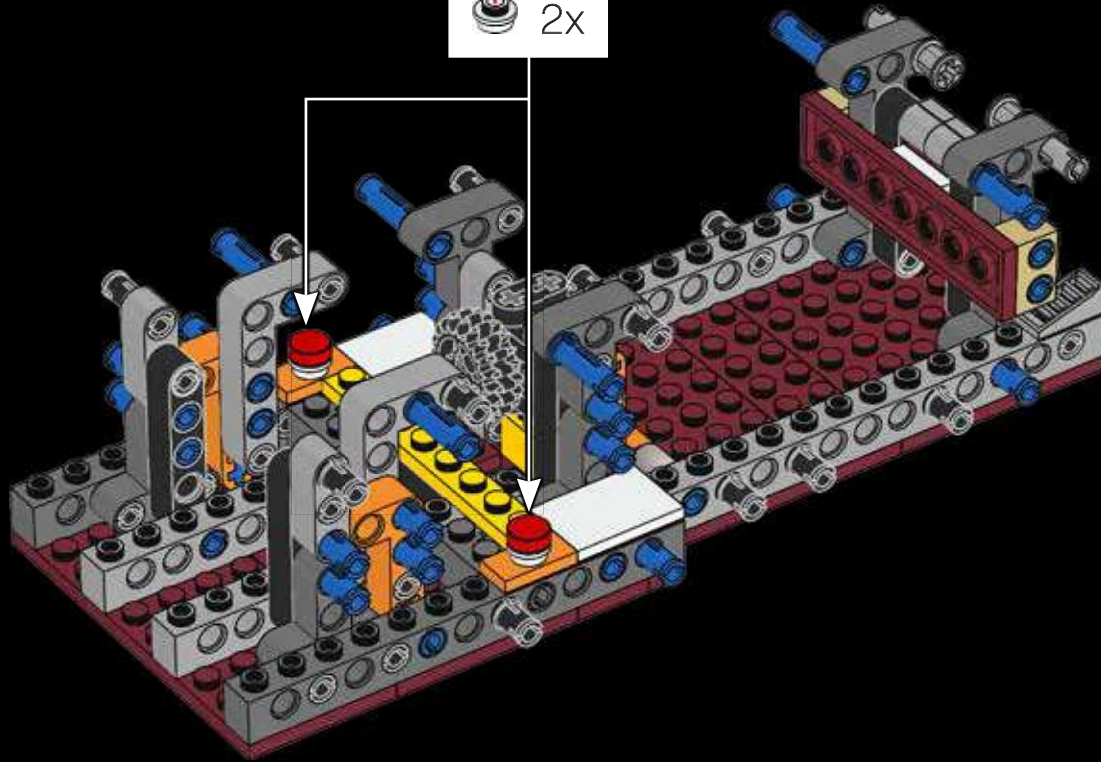



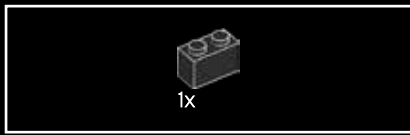

42

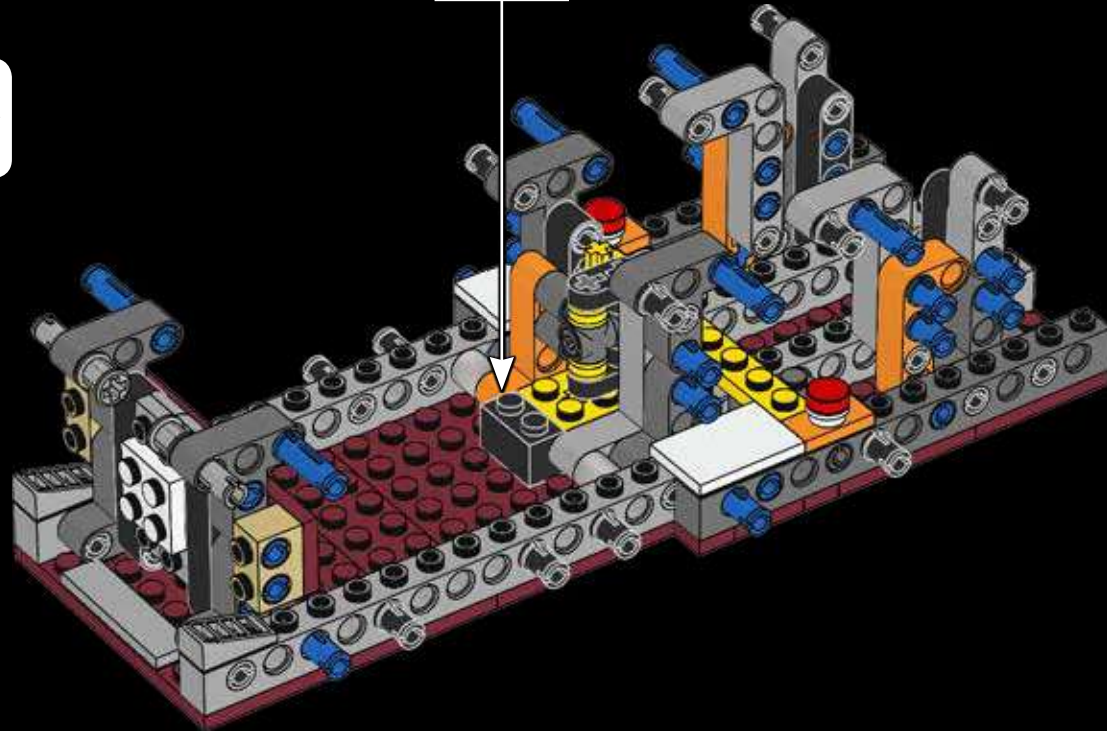



1x

43

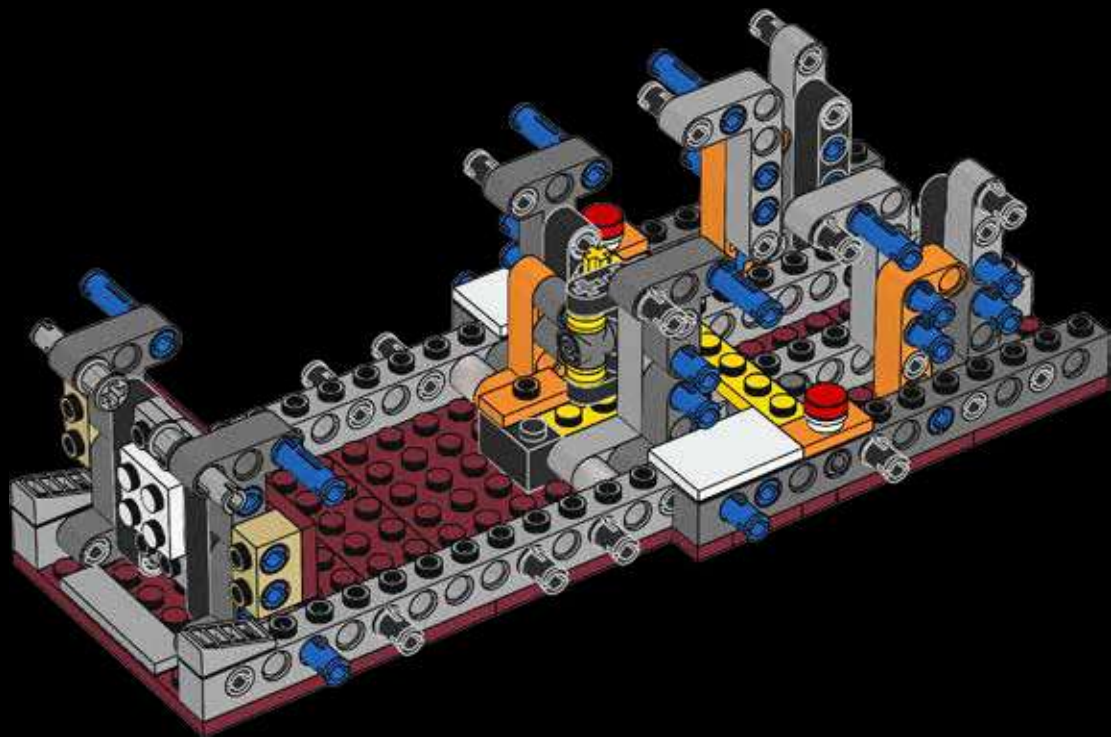

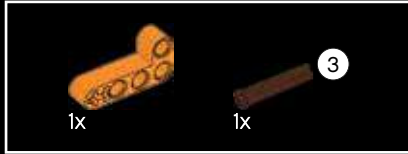

44



45

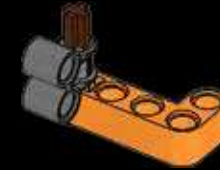

46

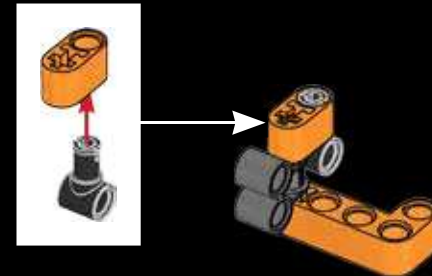

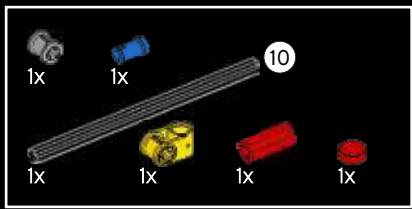

47

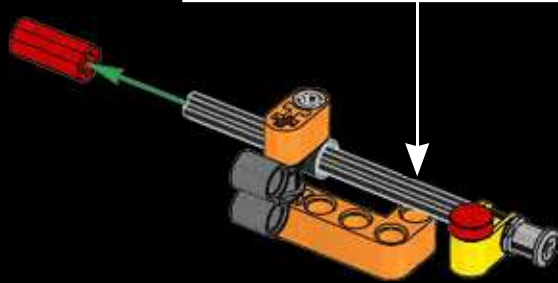
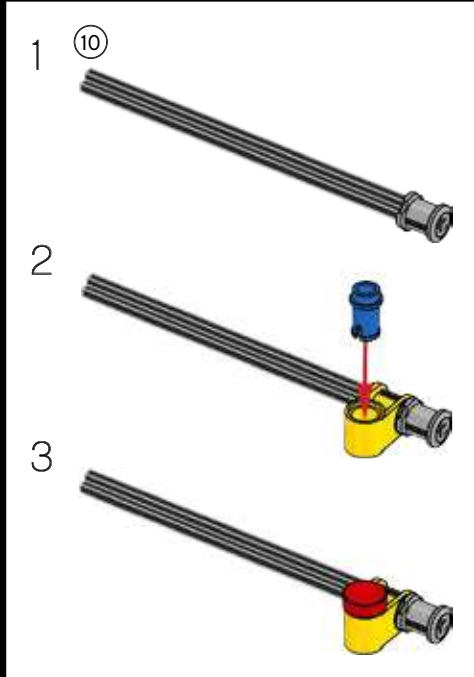

44

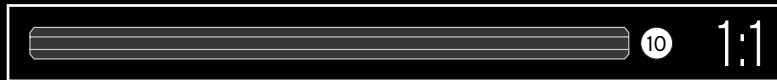

48

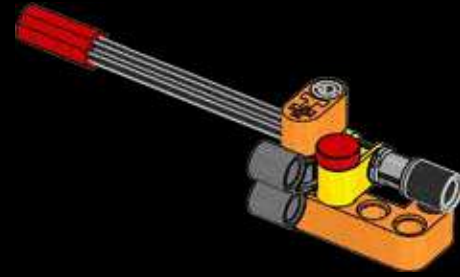

49

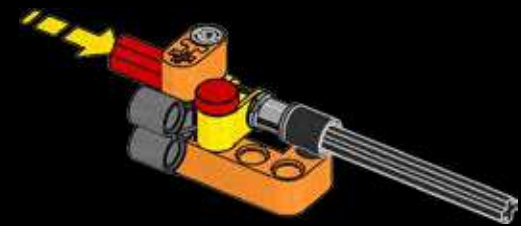



50



51

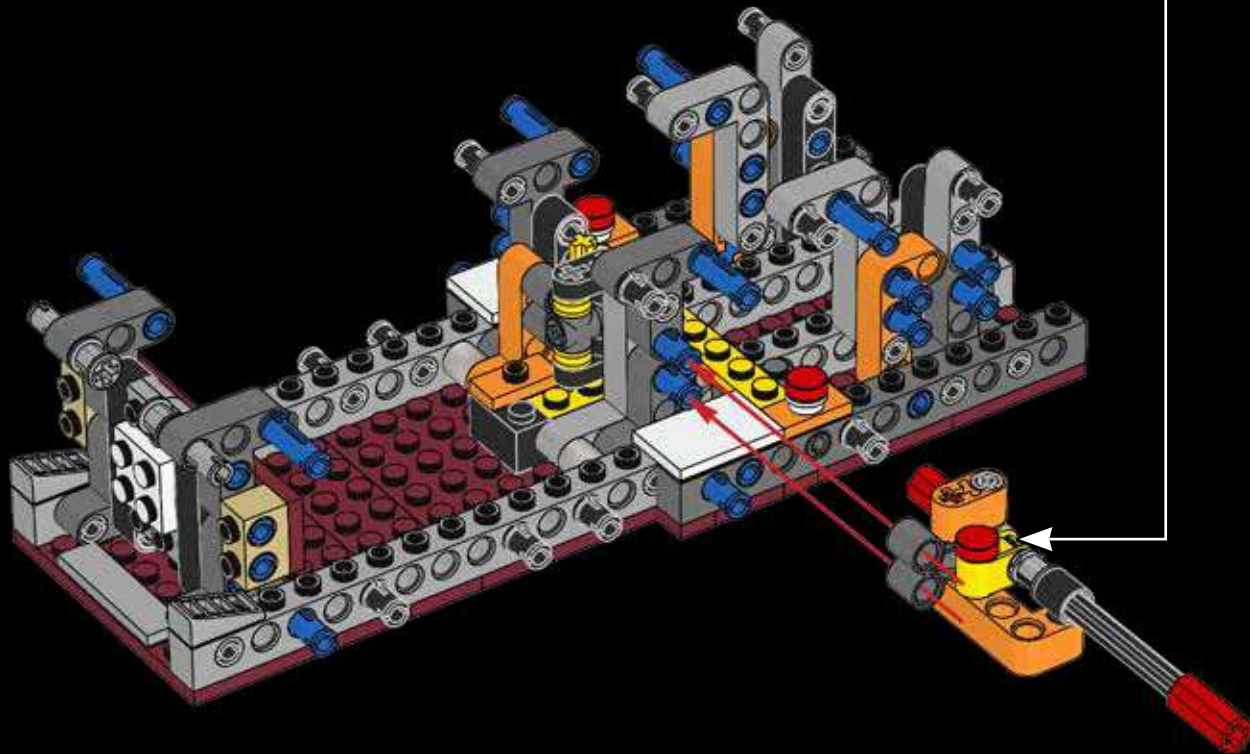



52

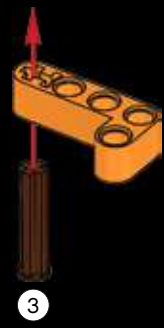

53

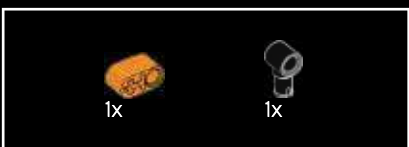
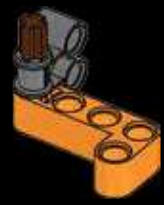

54

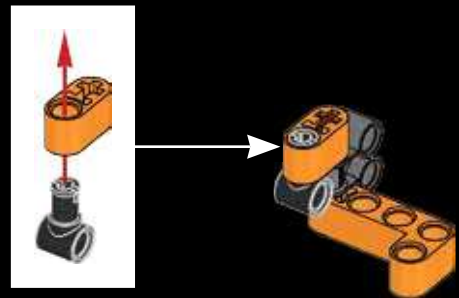

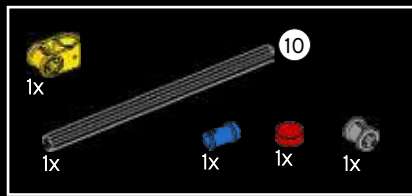

55

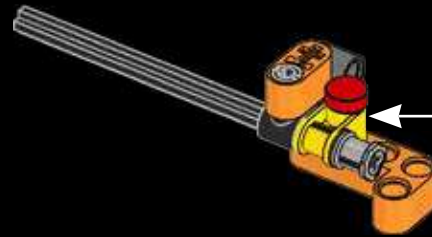
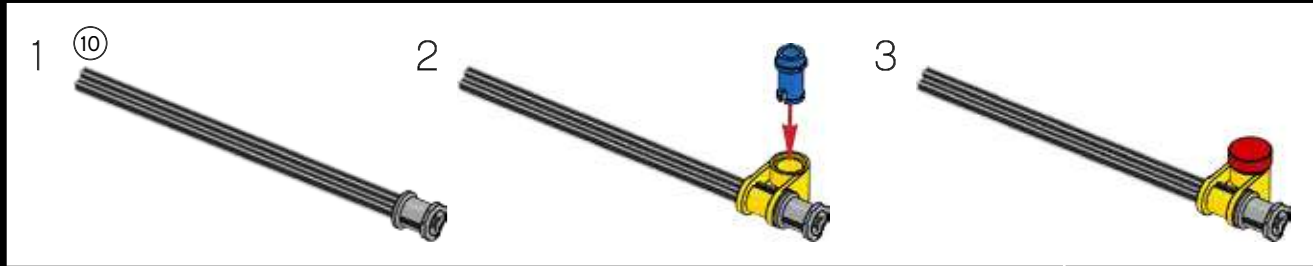

56

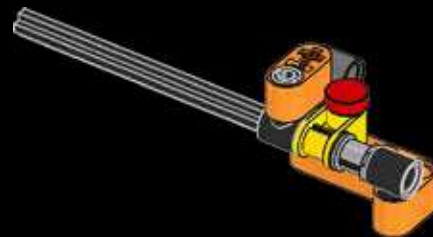

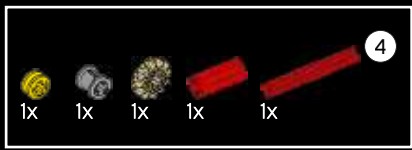

57

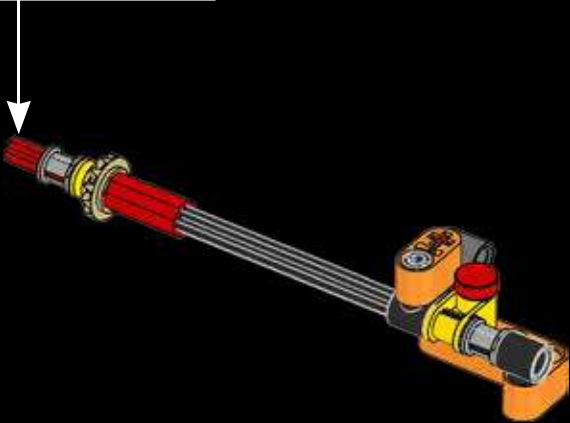
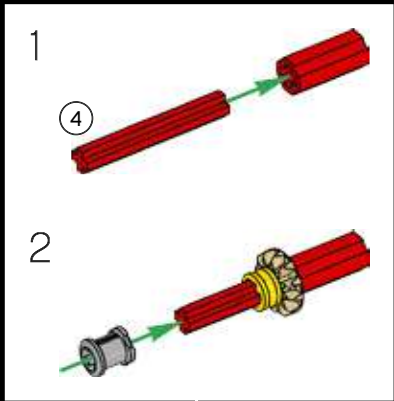

58

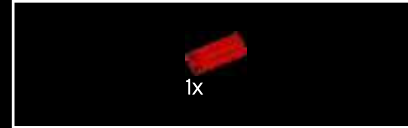
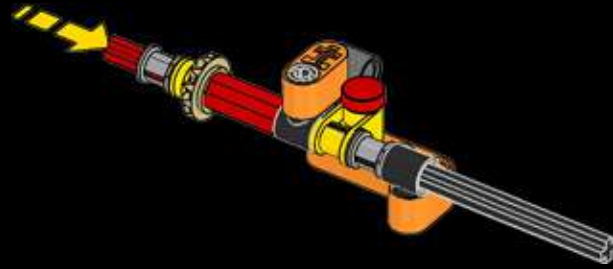

59

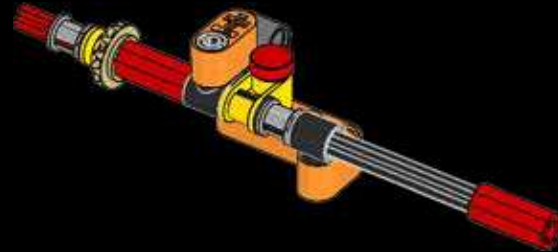



60

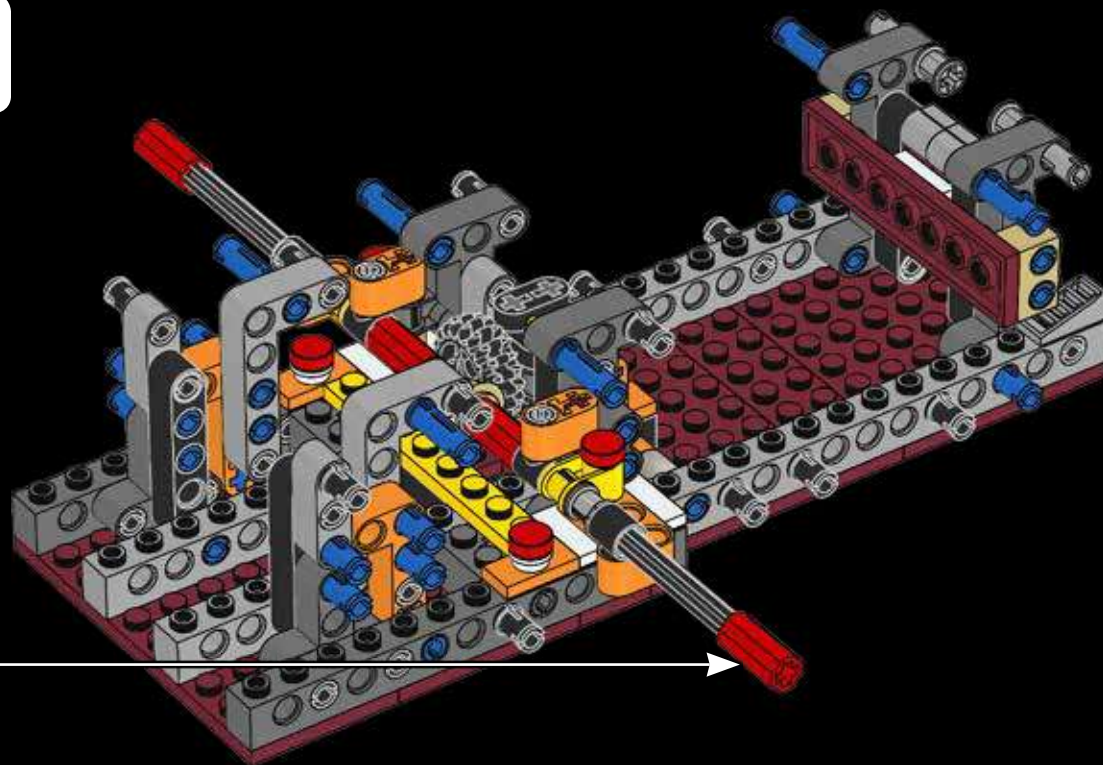

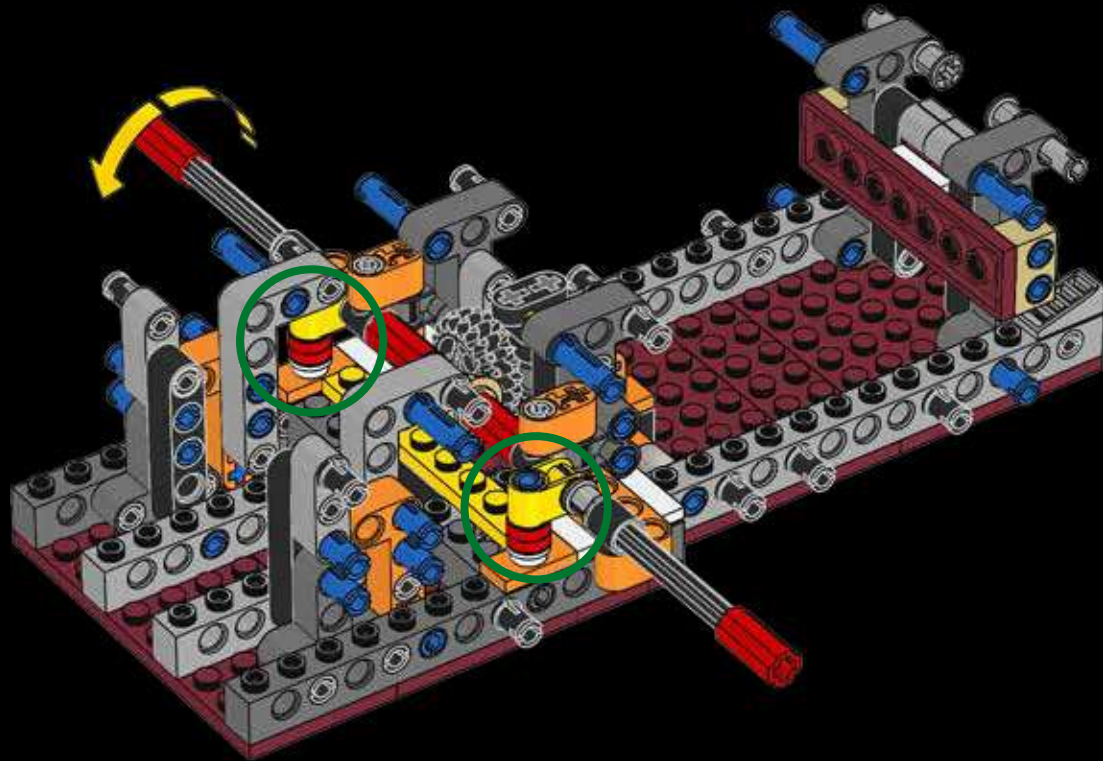

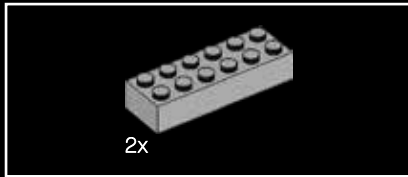
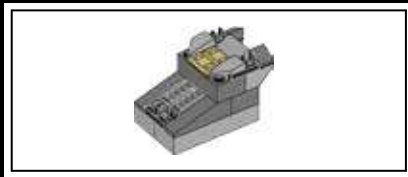
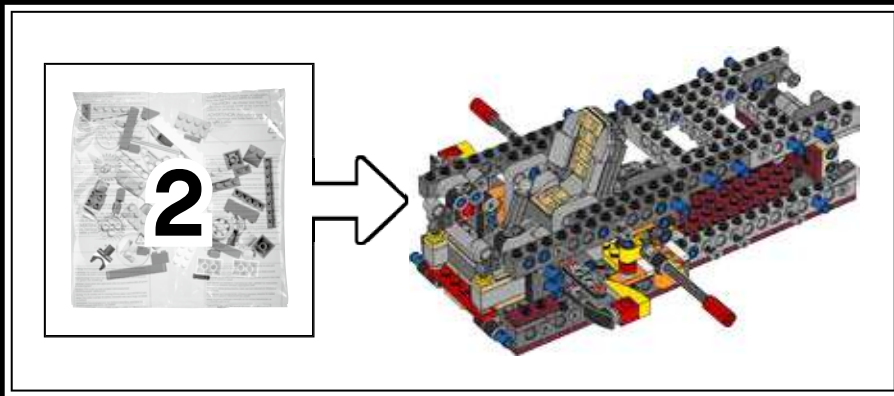

62

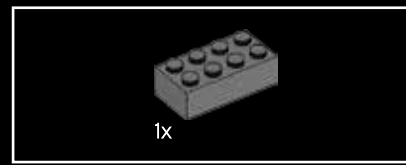
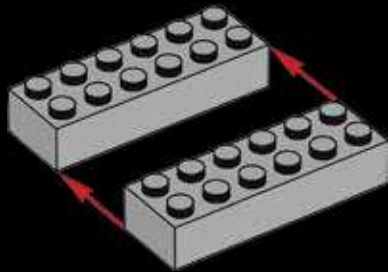

63

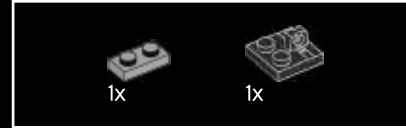
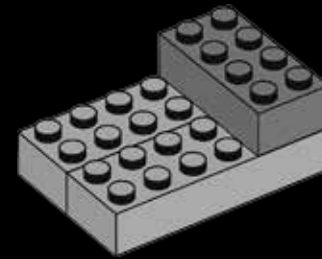

64

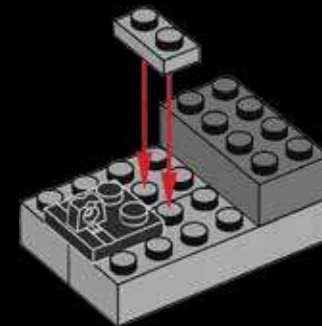

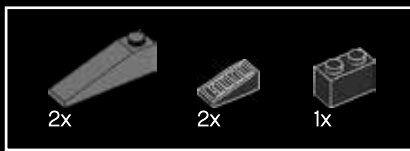

65

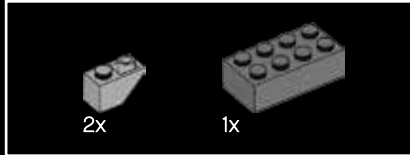
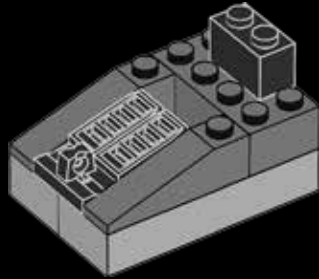

66

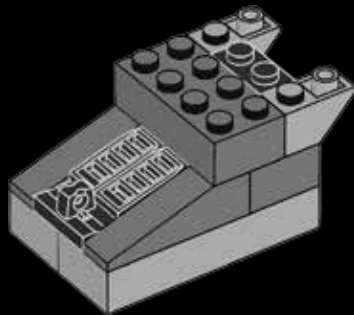

67

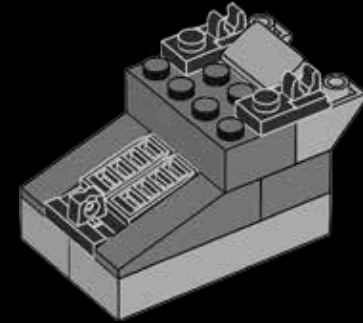

68

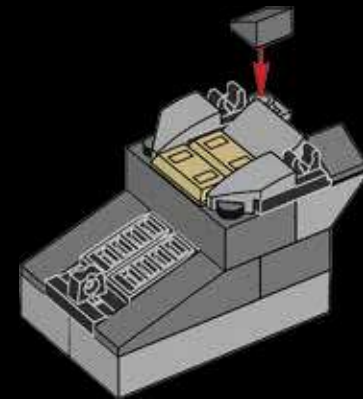

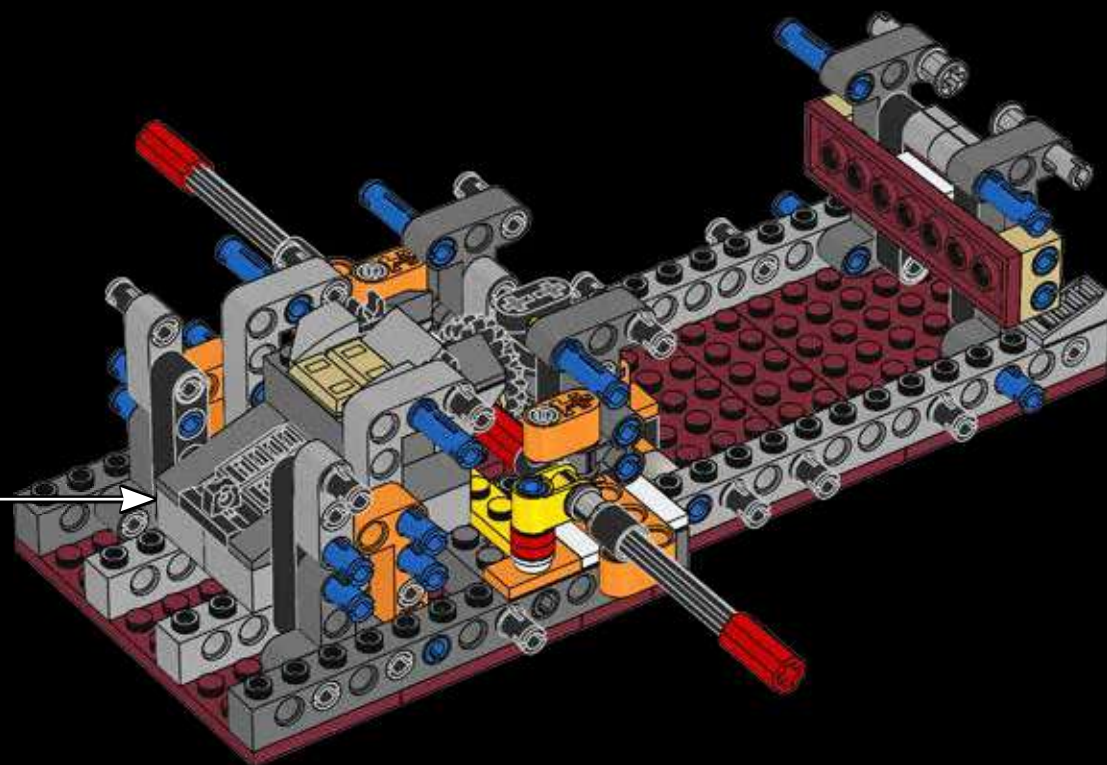

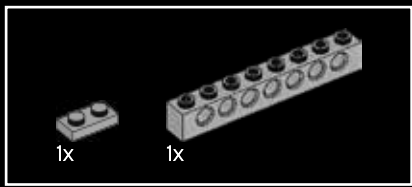

70

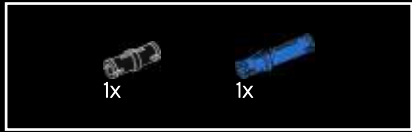
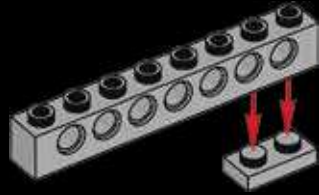

71

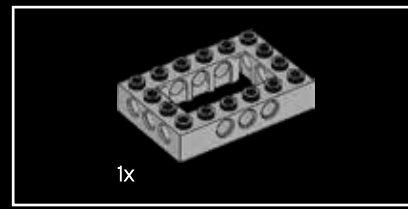

72

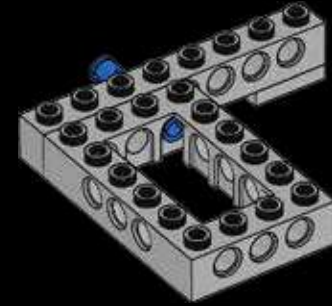

73

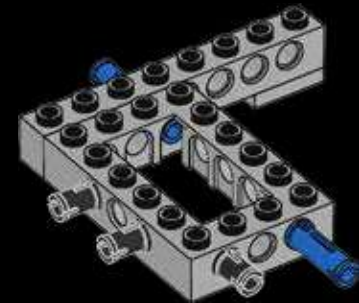

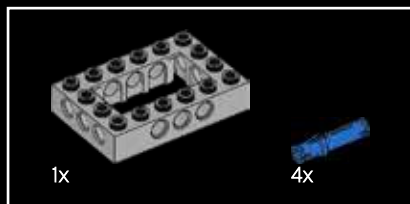

74

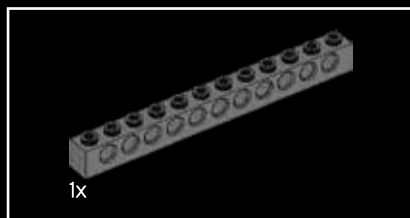
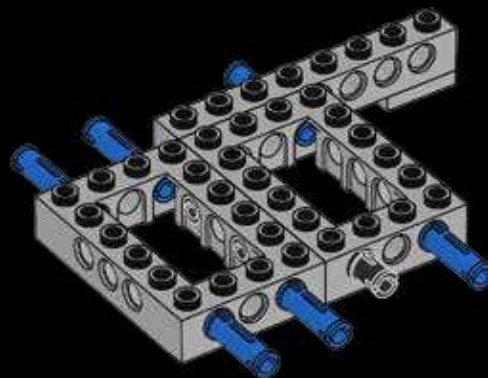

75

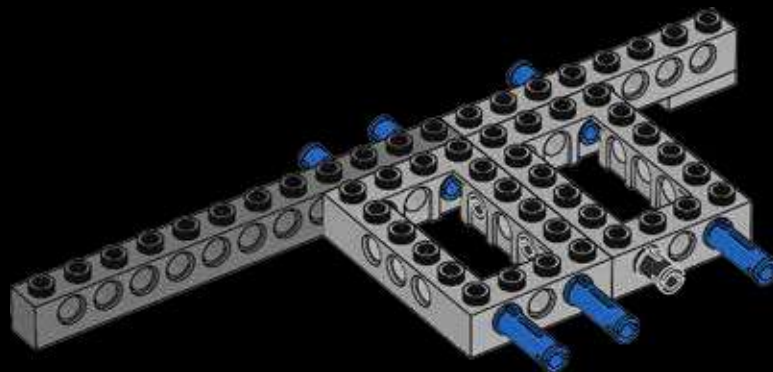

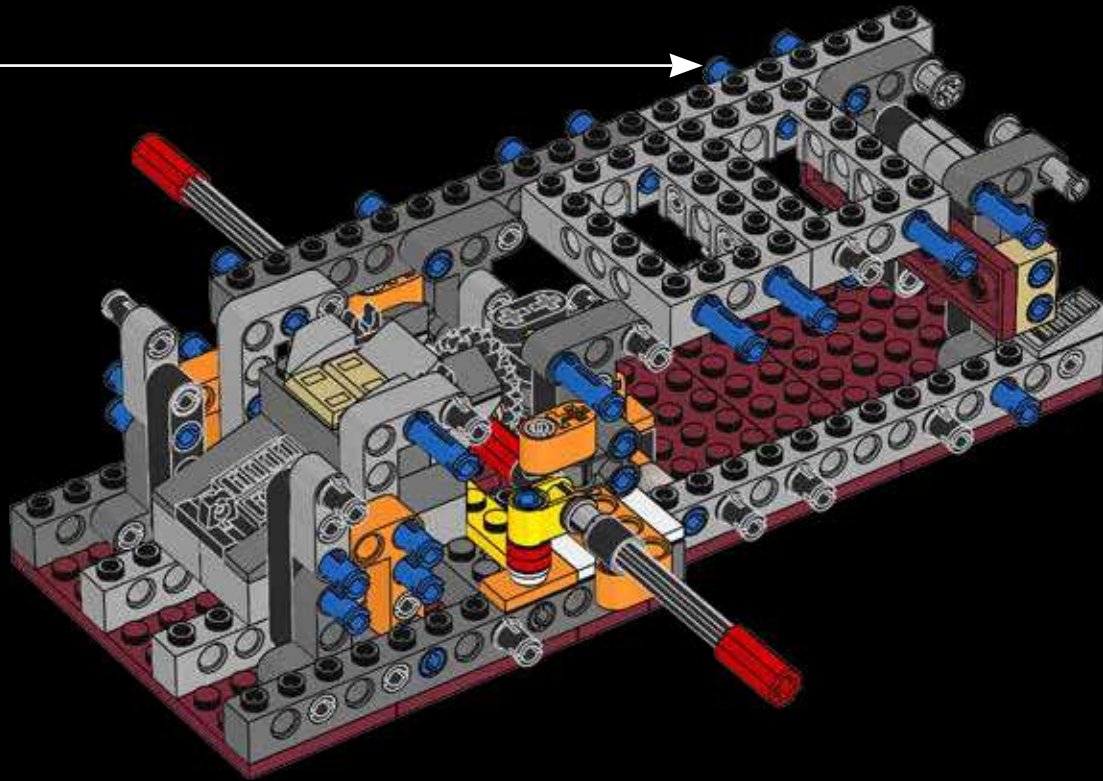



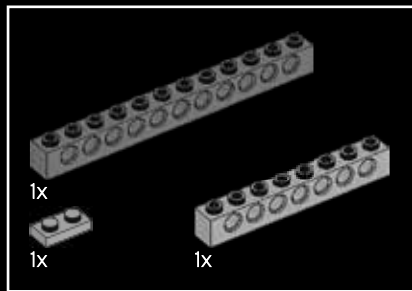

77

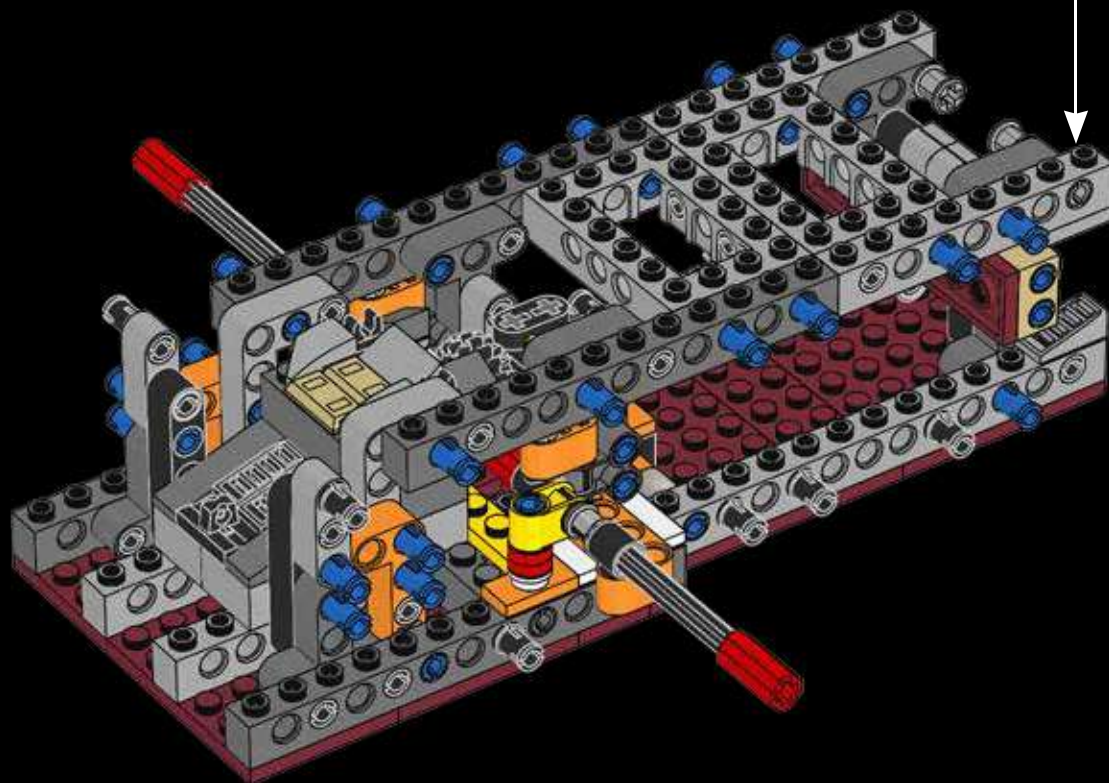
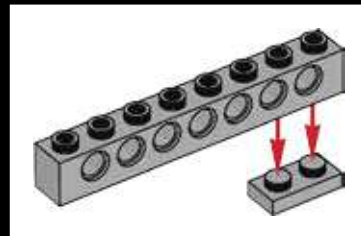



78

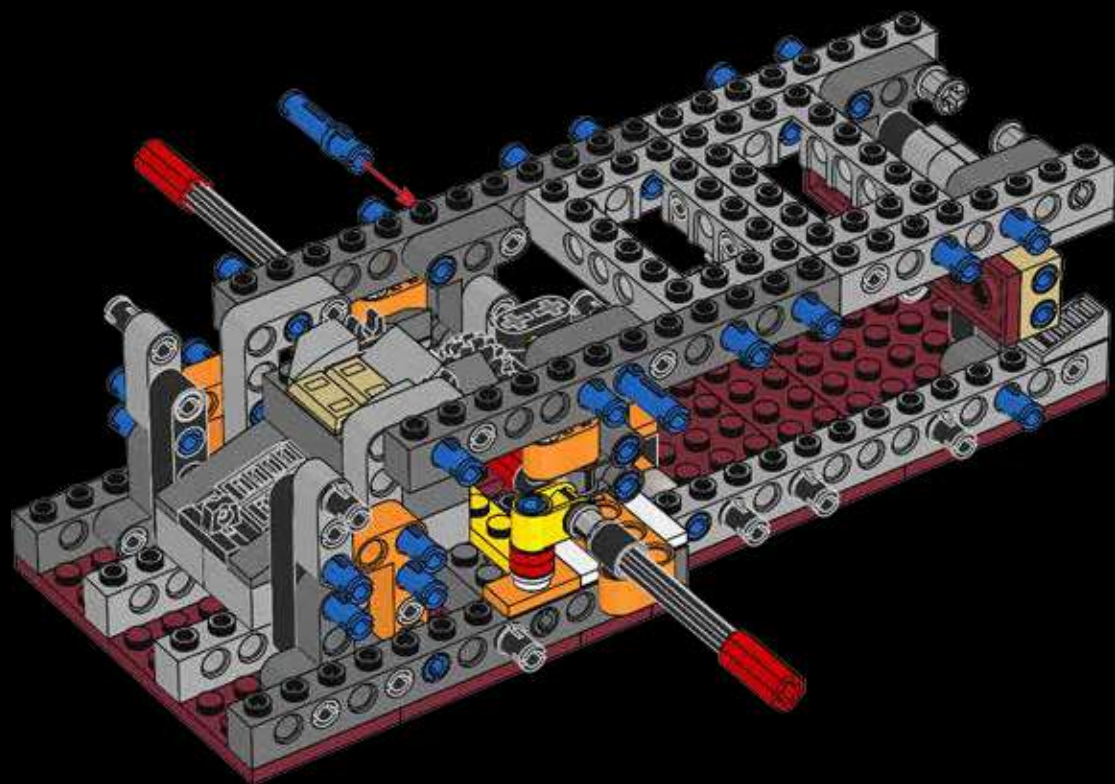



79

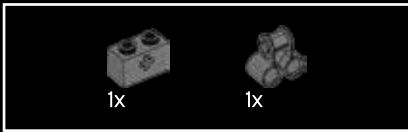

80



81



82





83

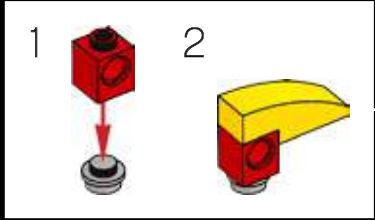

84



2x

85

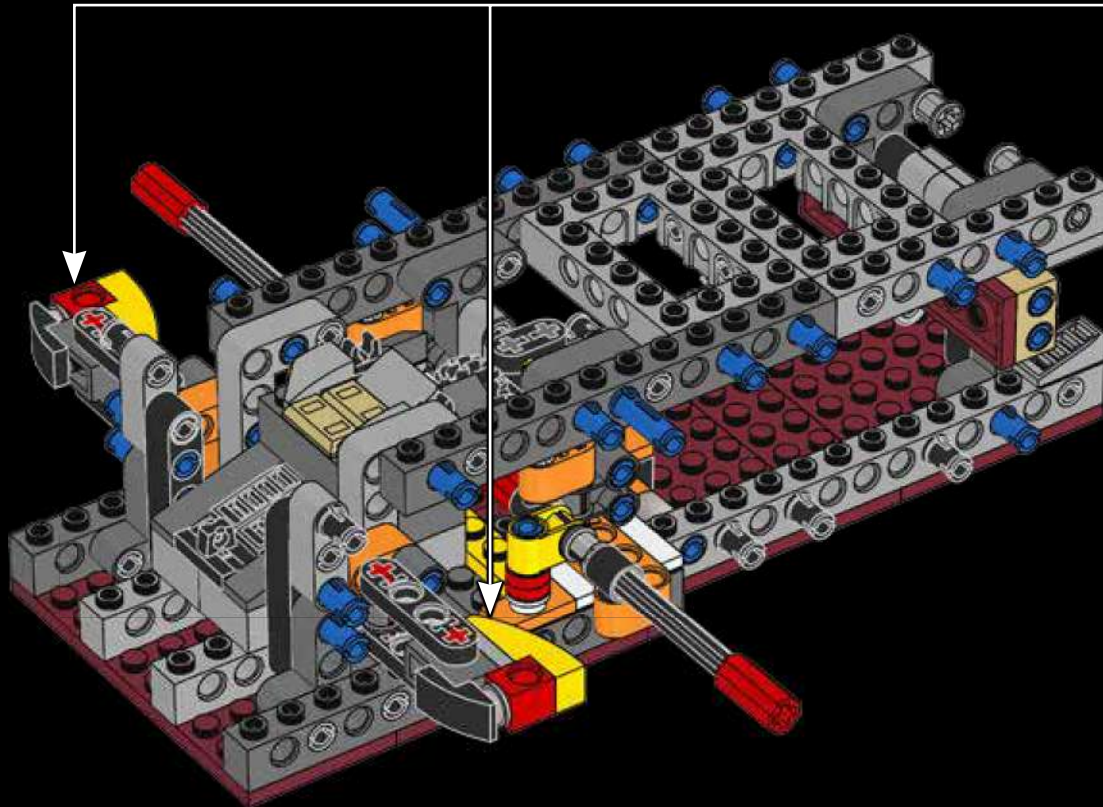



86

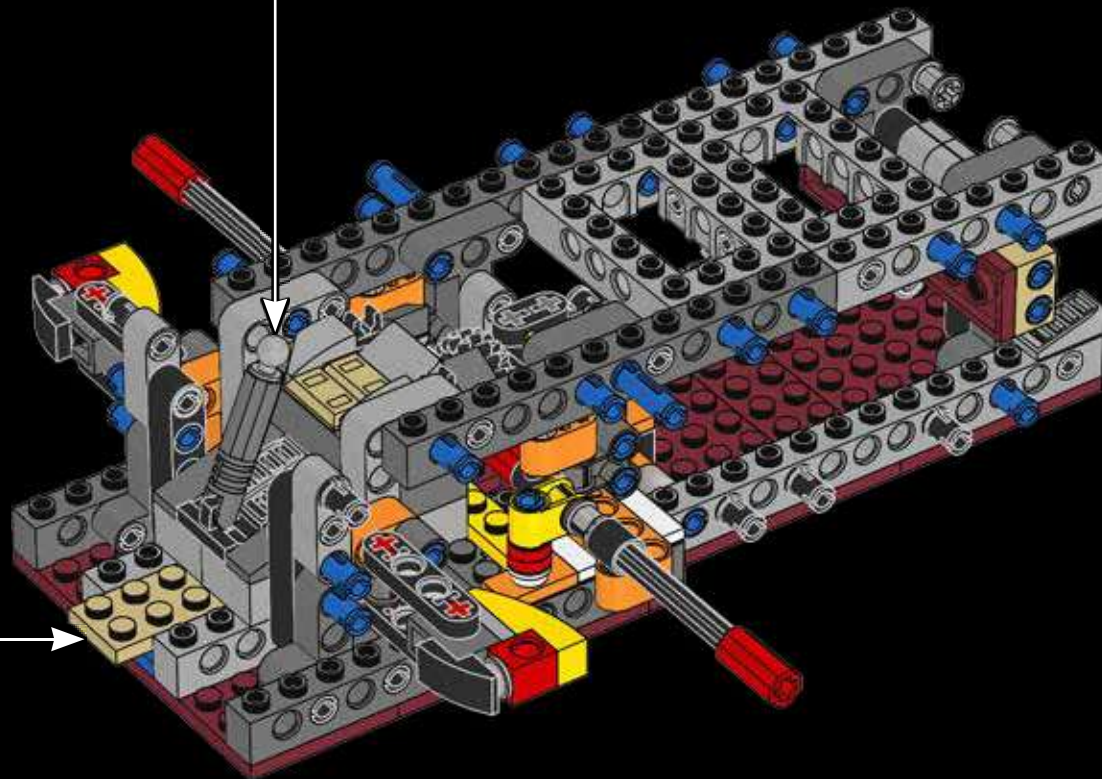
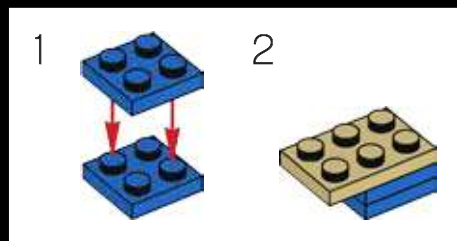
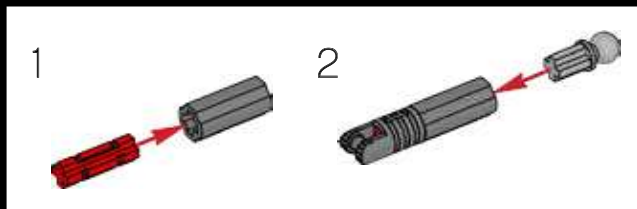



87

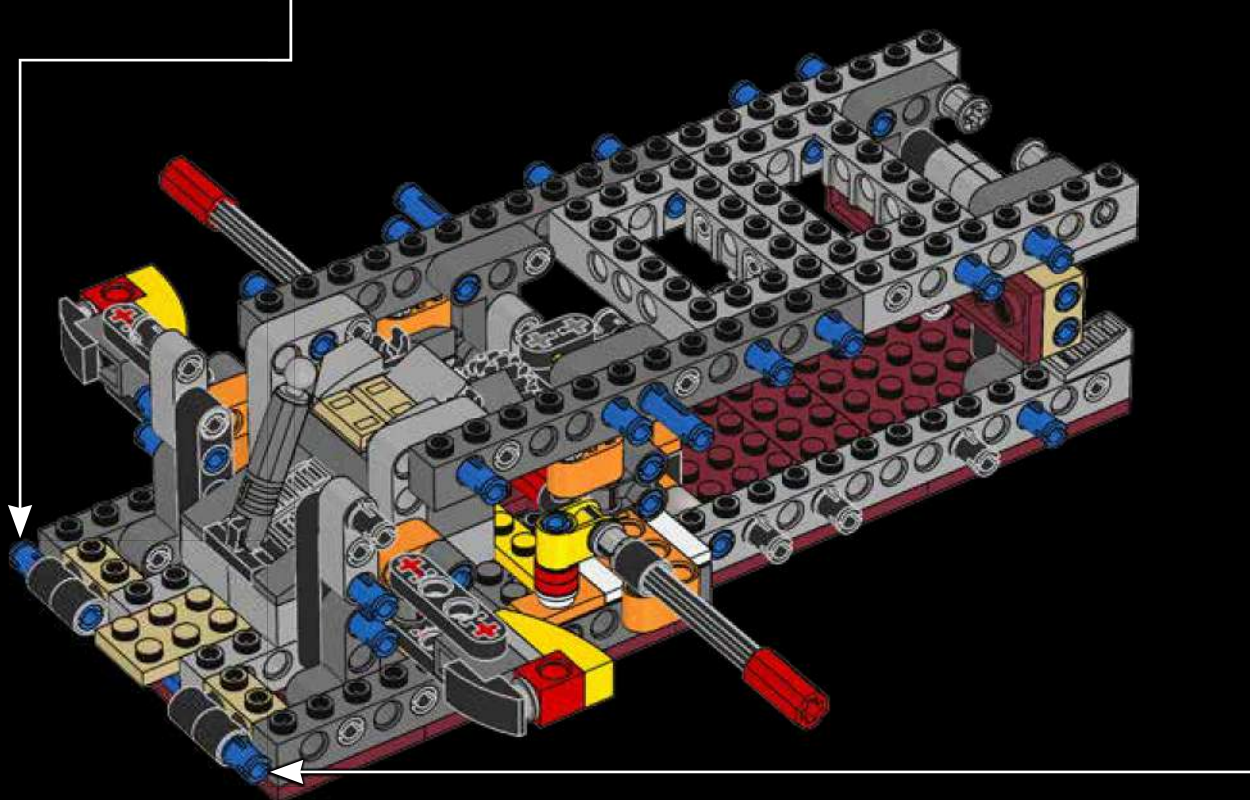
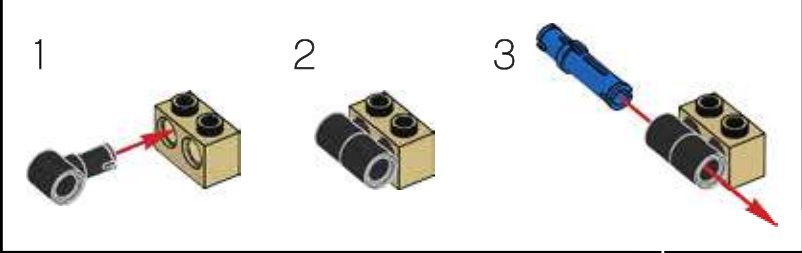

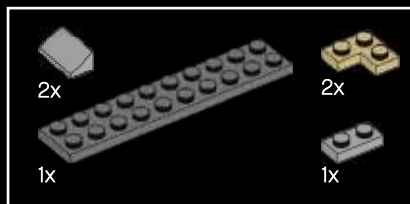

88

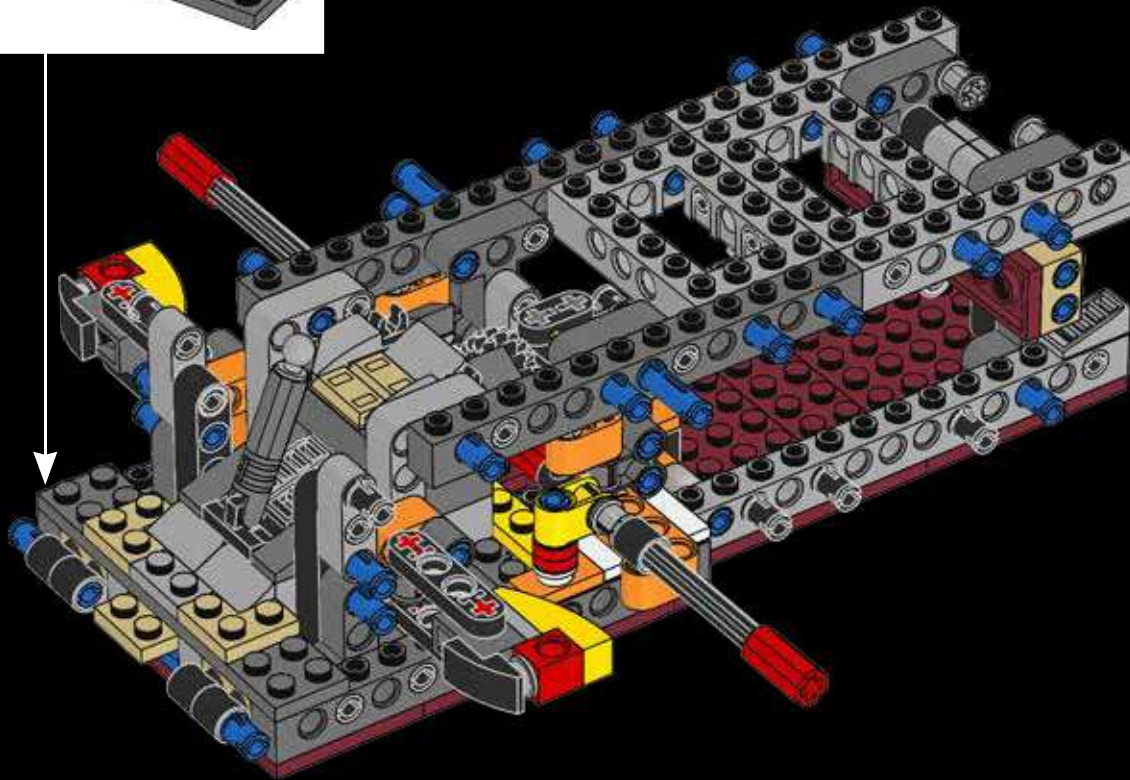
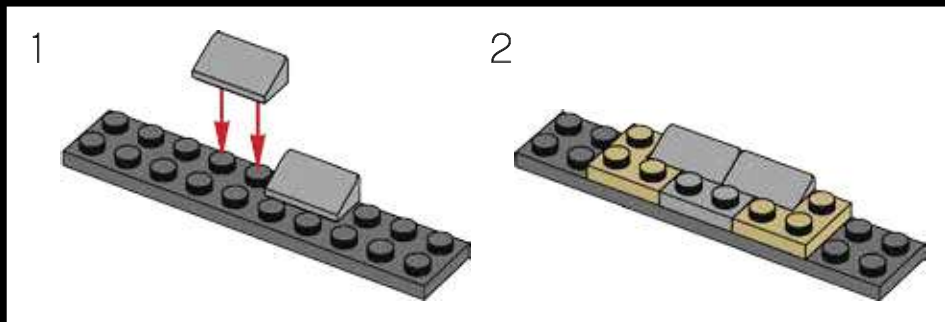

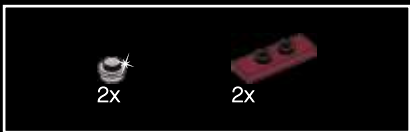

89

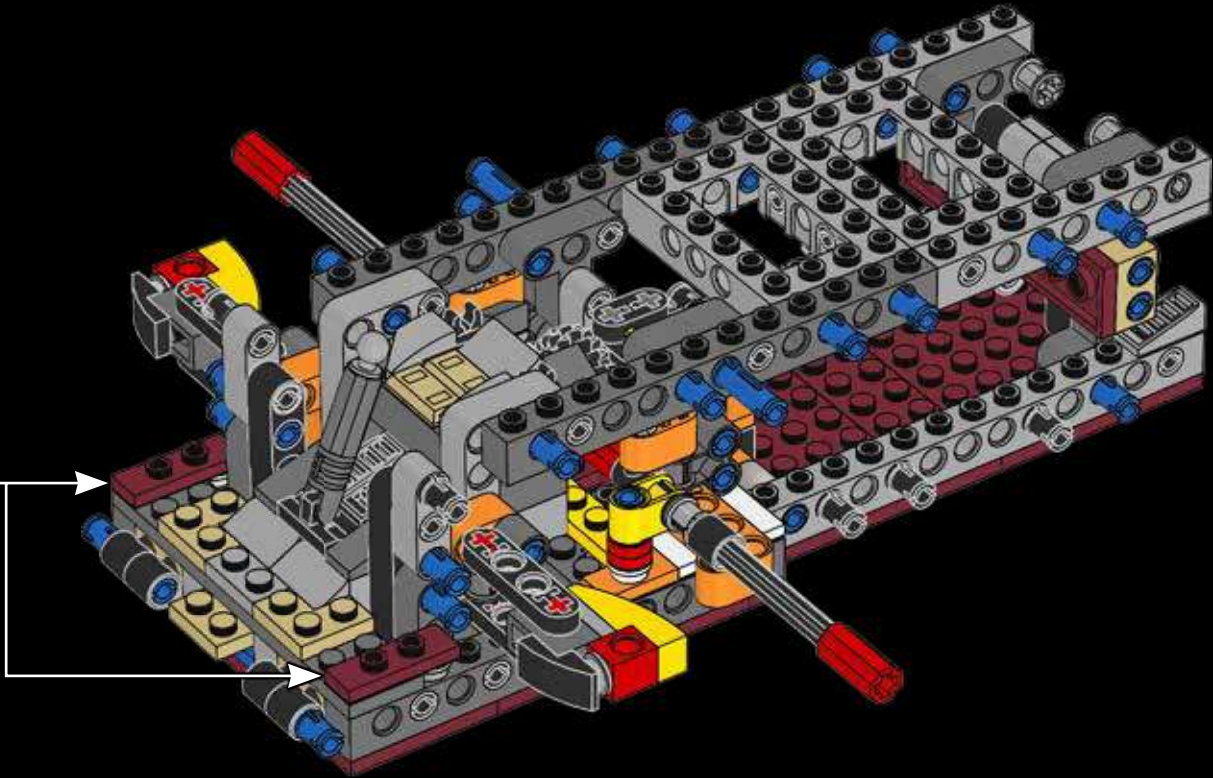
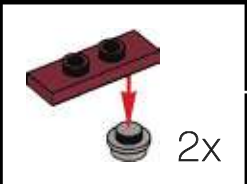





90

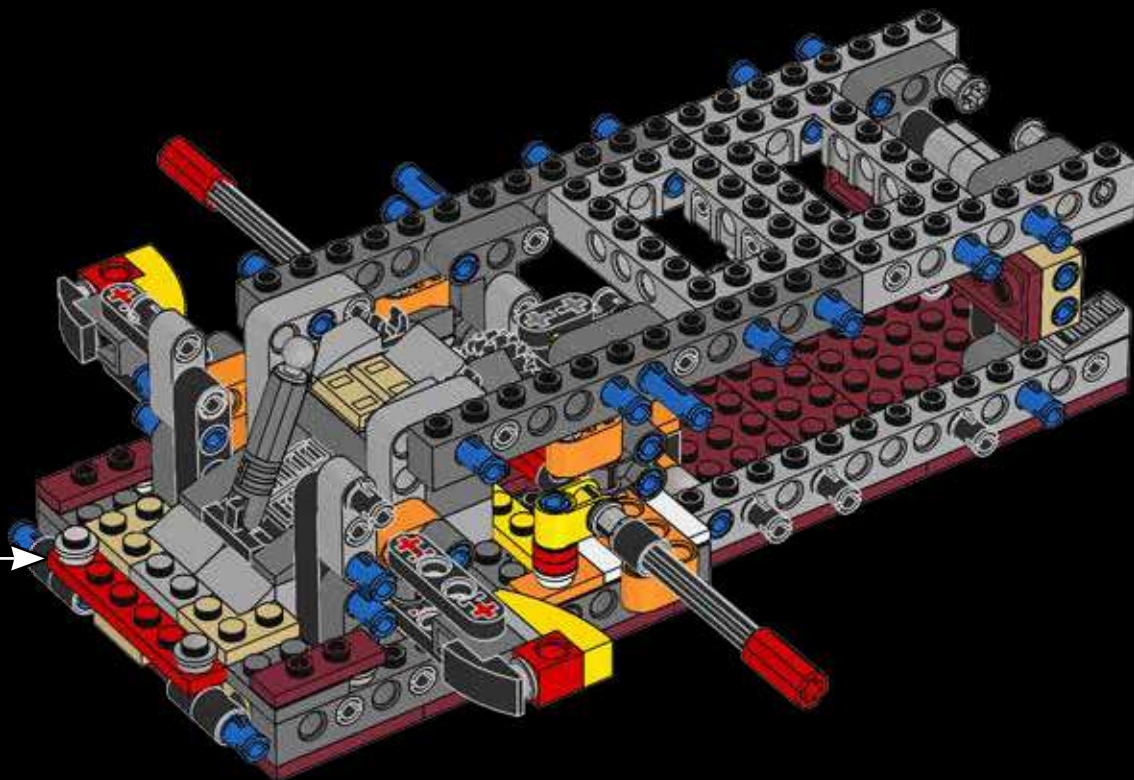
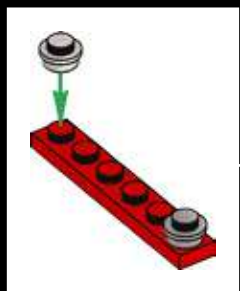

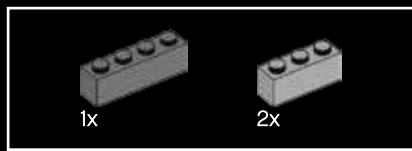

91

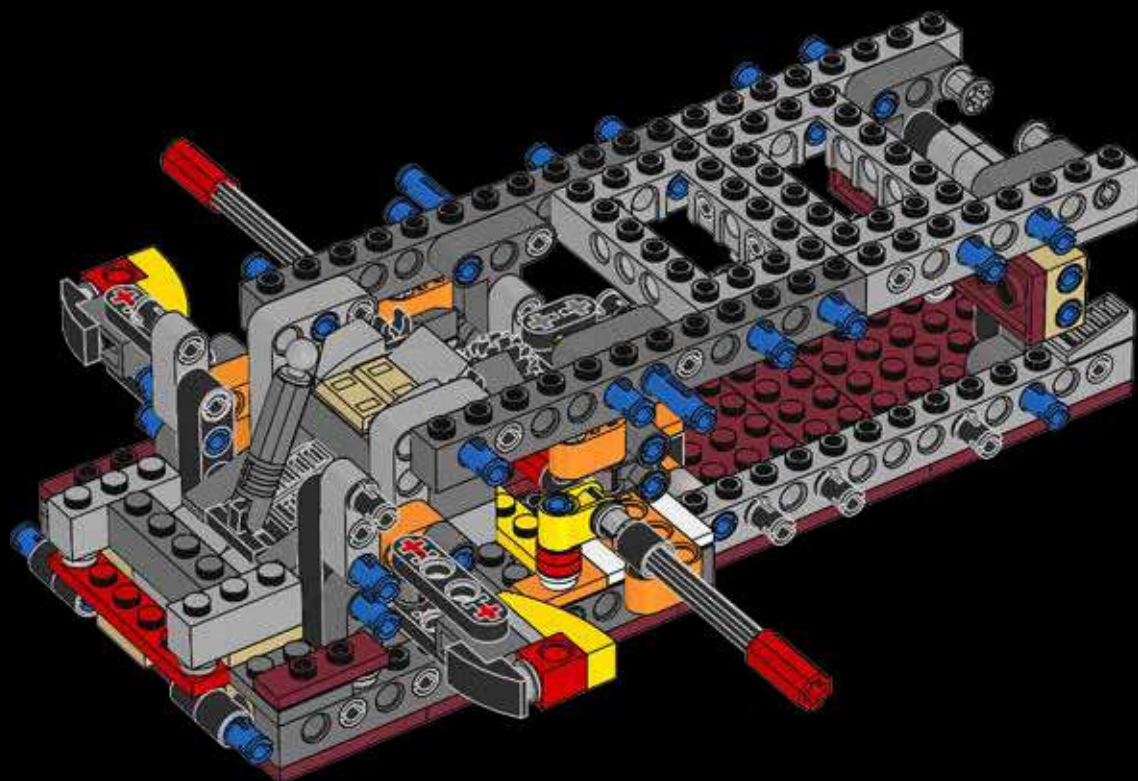

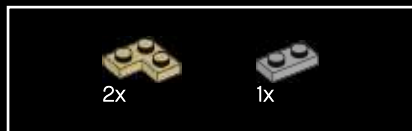

92

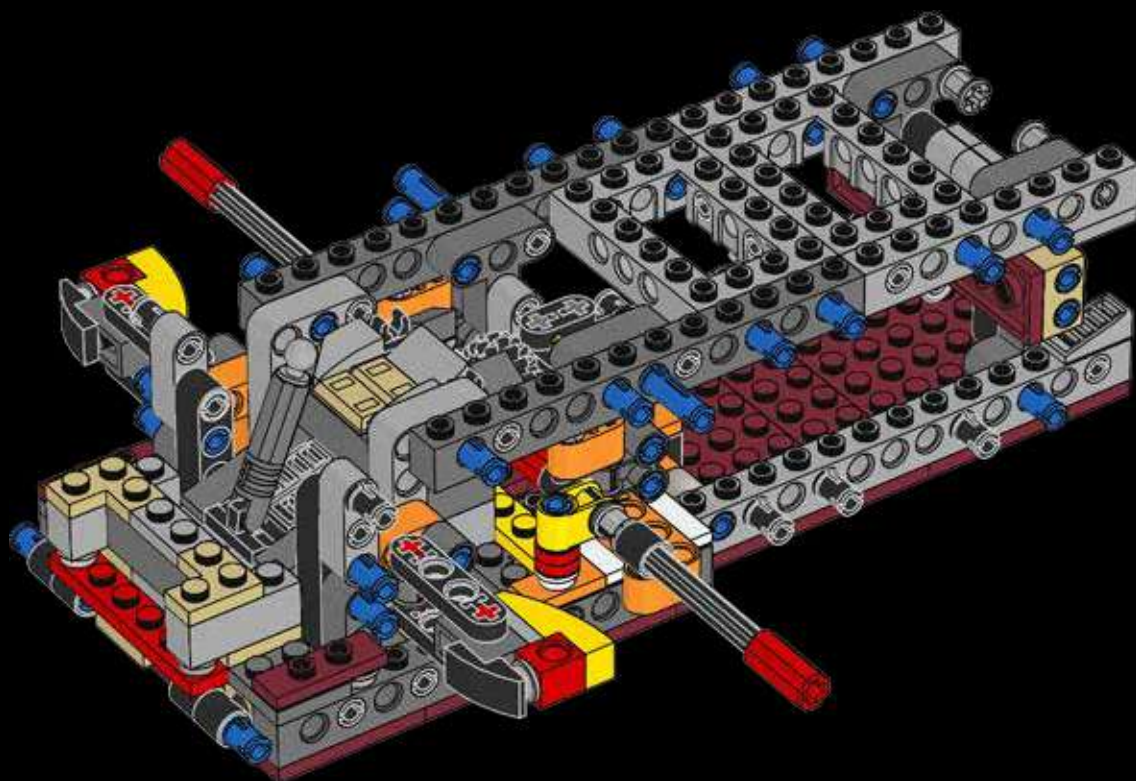

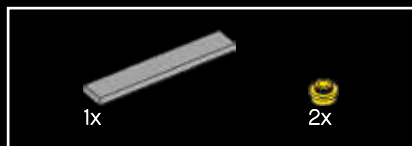

93

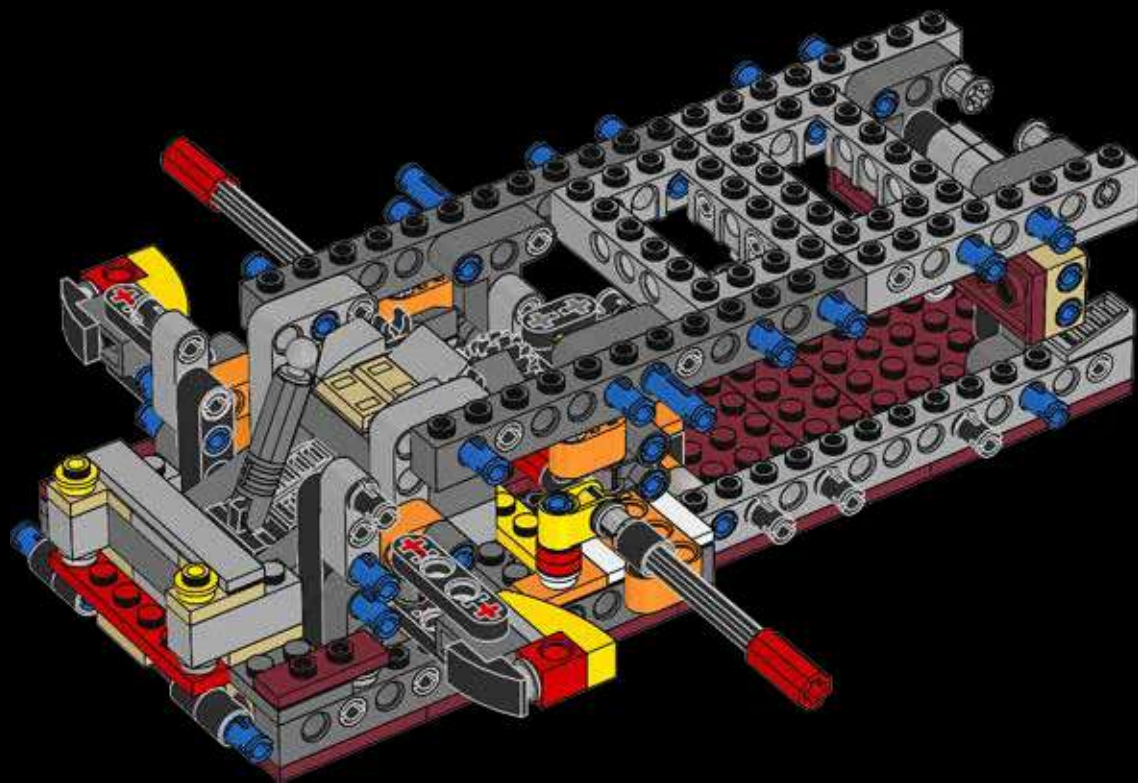

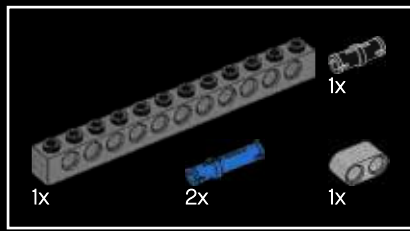

94

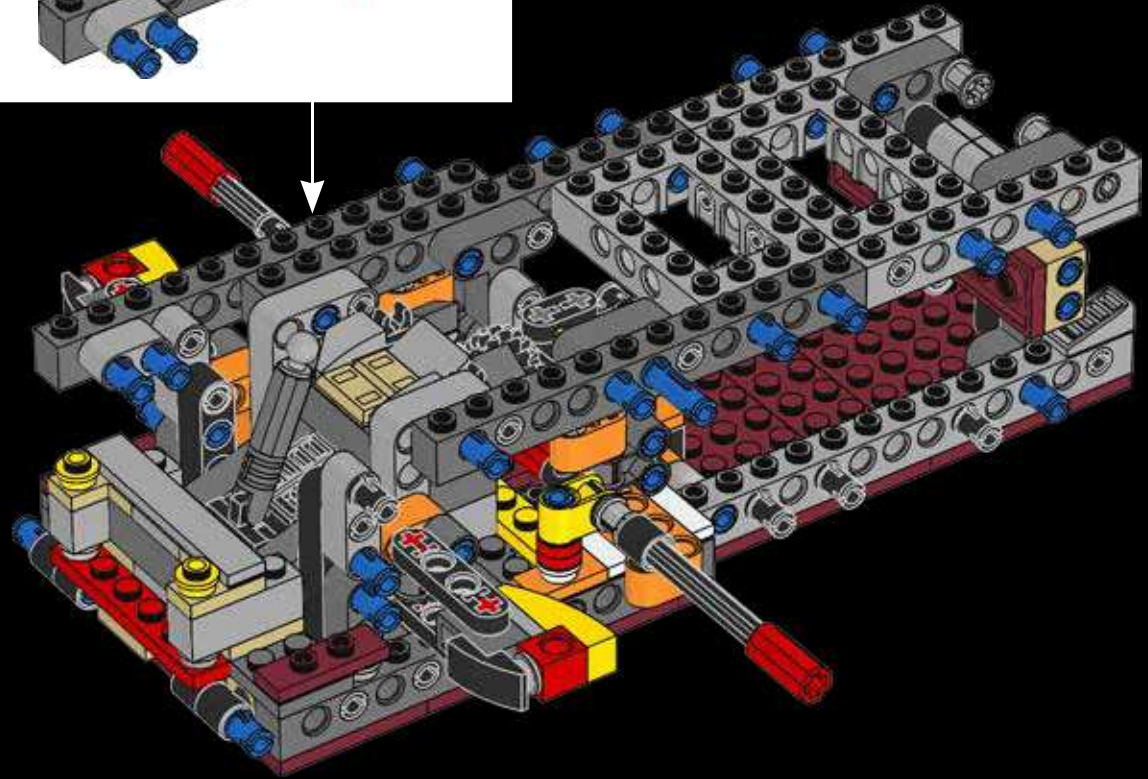
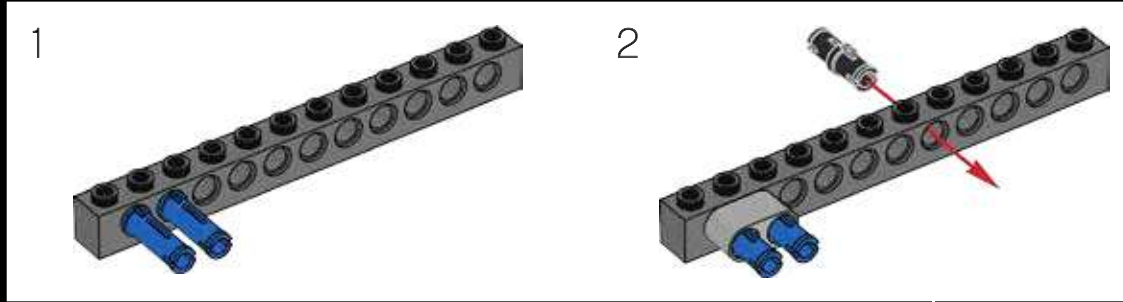

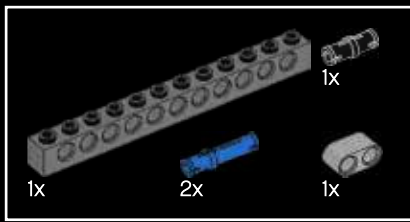

95

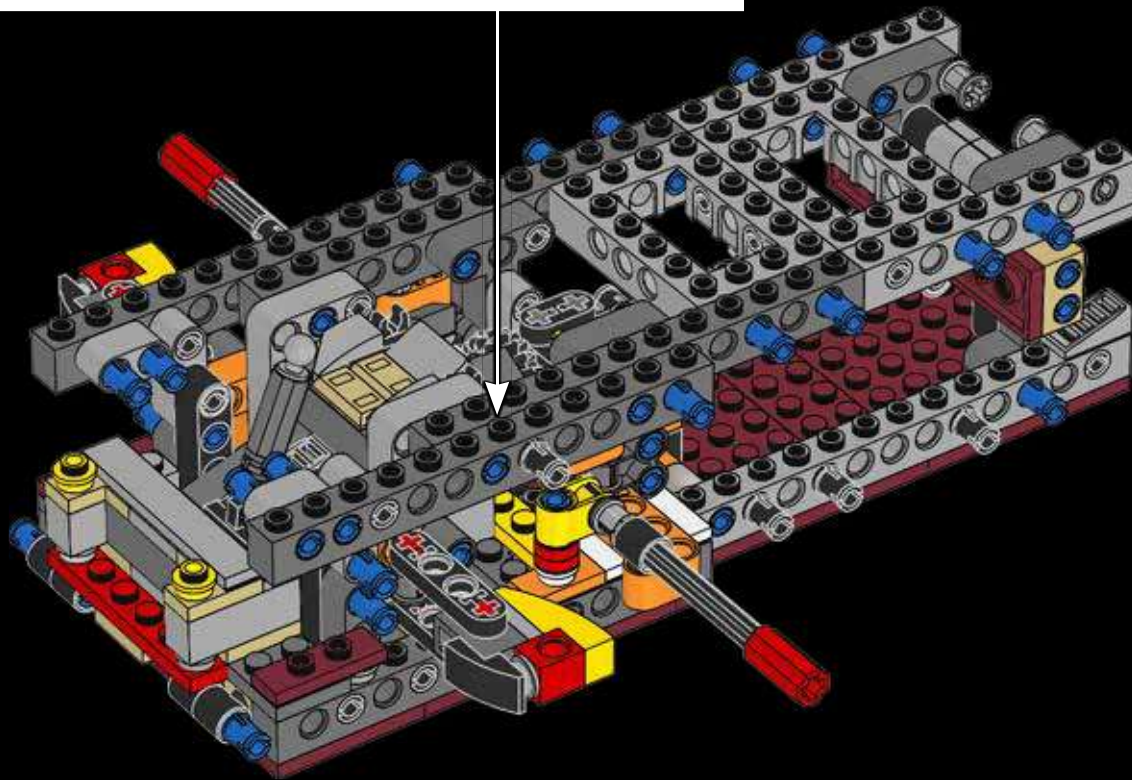
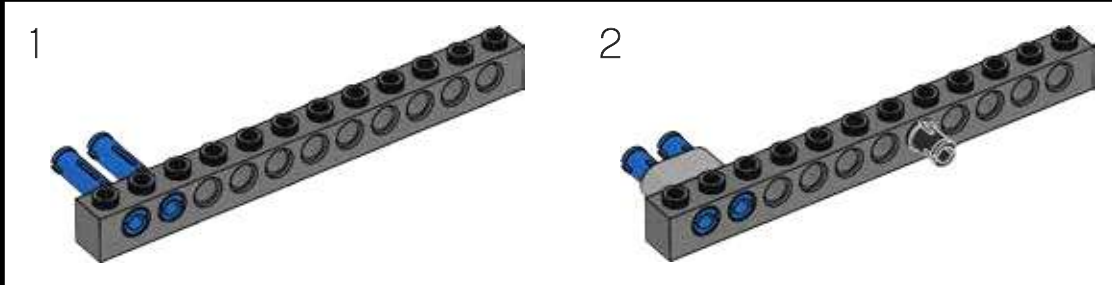



96

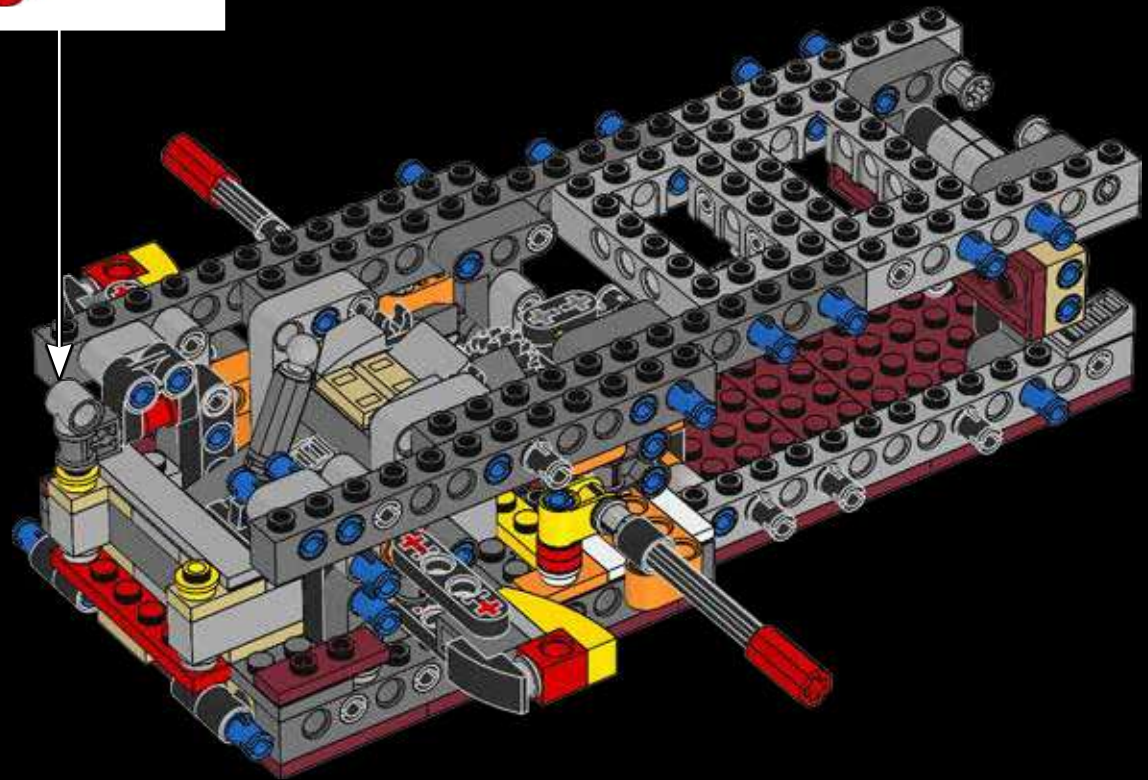
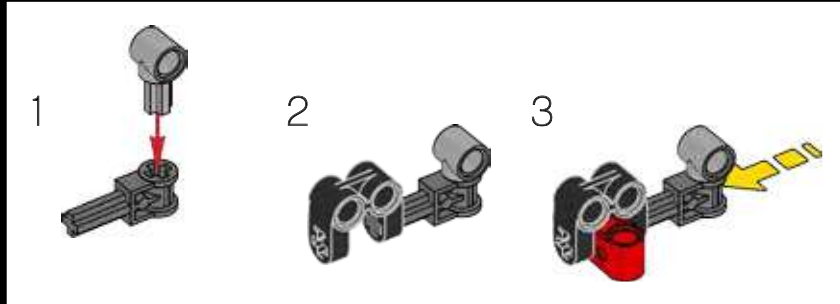



97

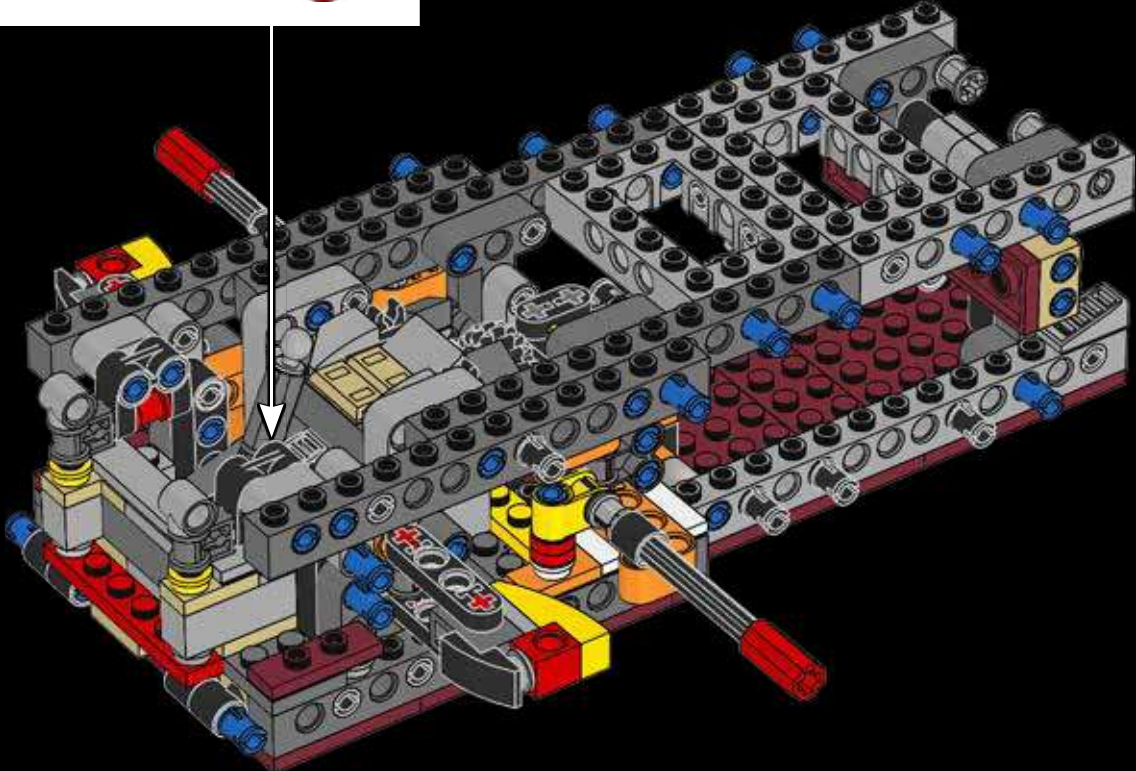
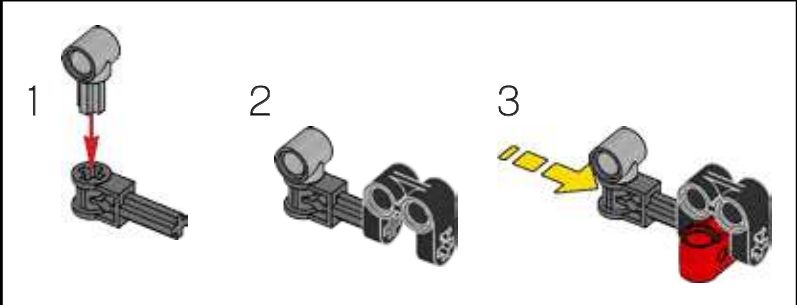



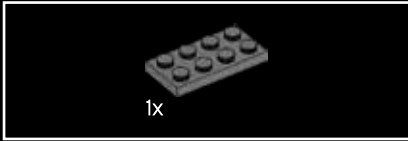

98



99



100

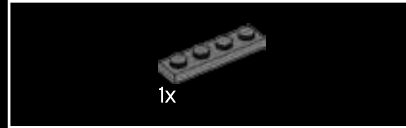

101

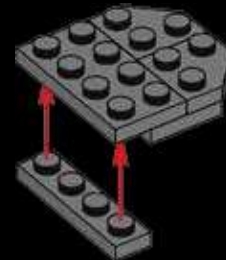



102

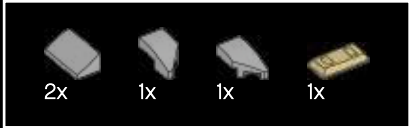
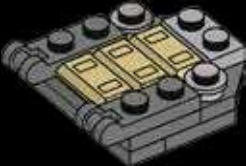

103

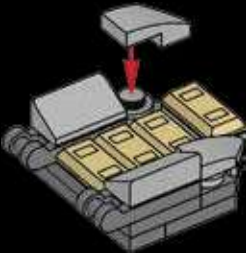

104

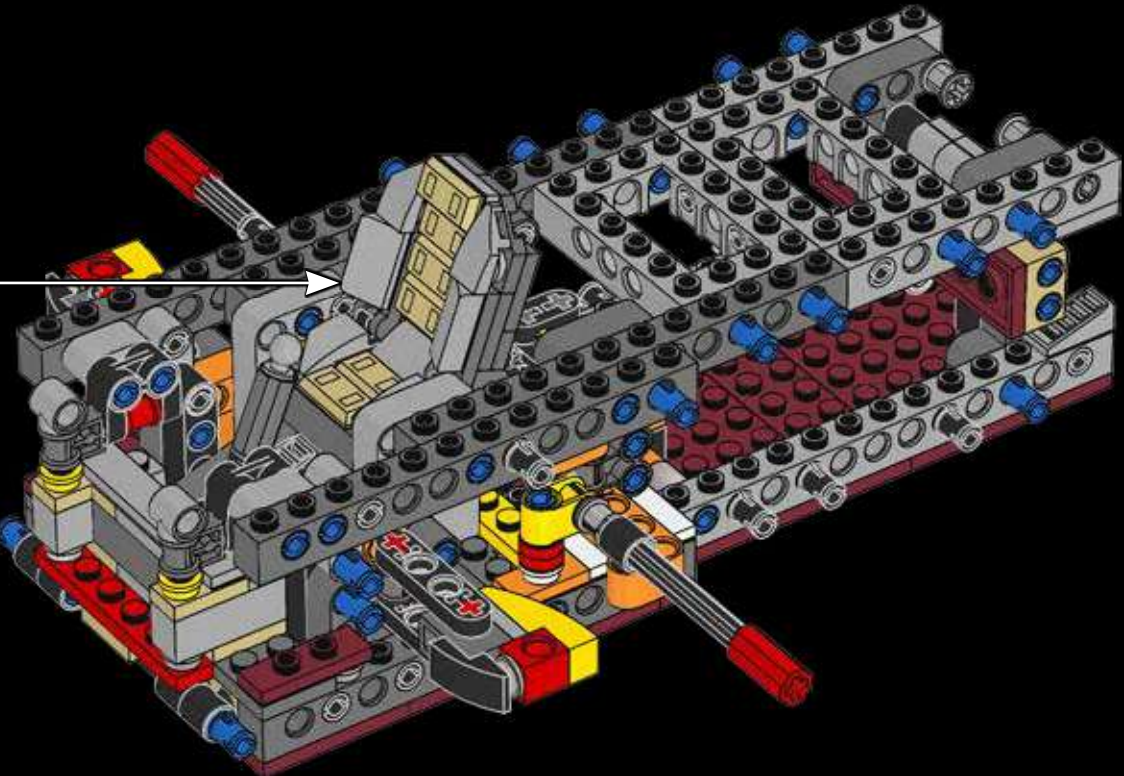

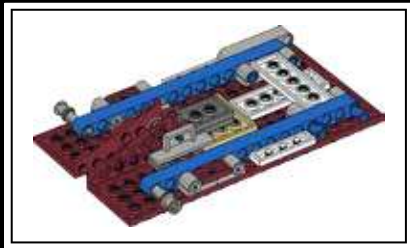
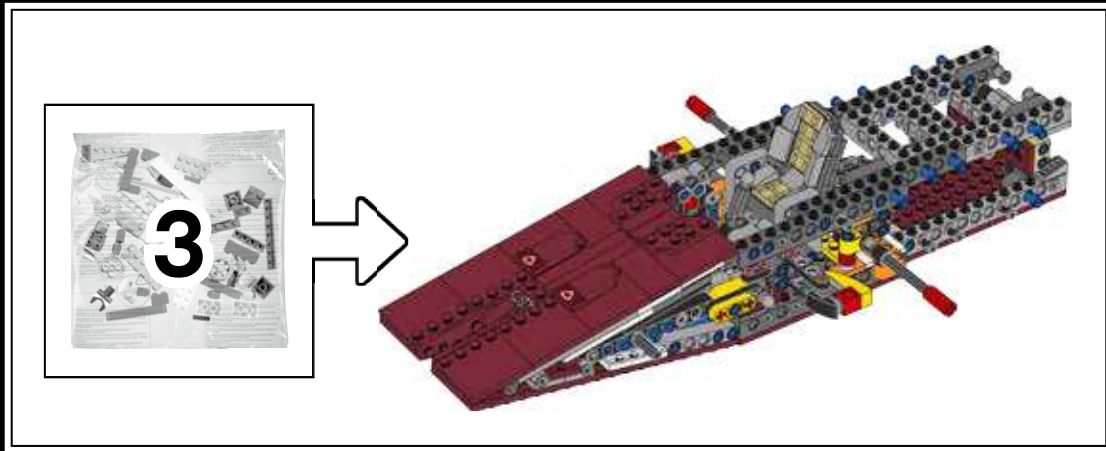

105

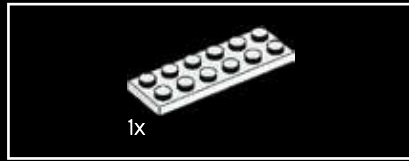

106



107





108



109

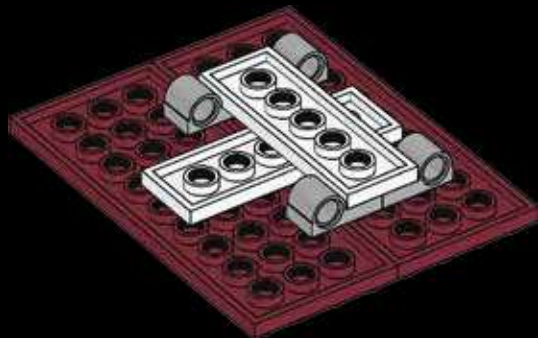

110

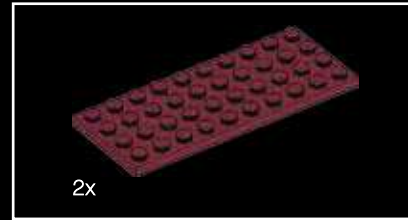

111

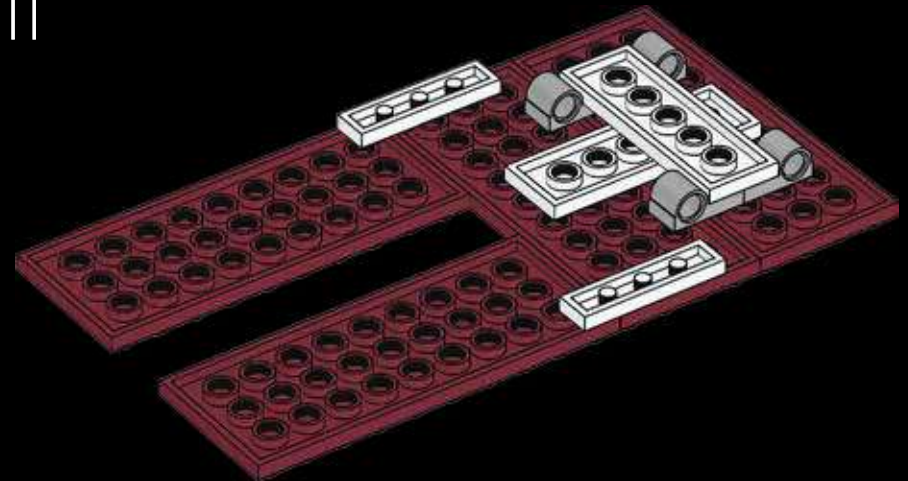

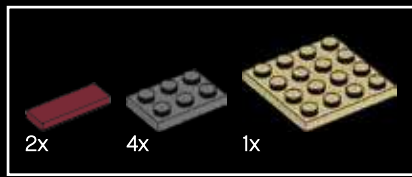

112

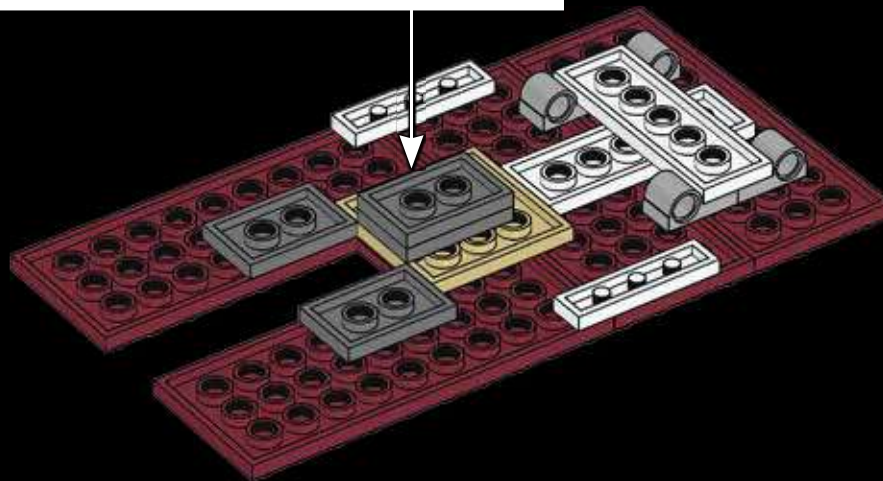
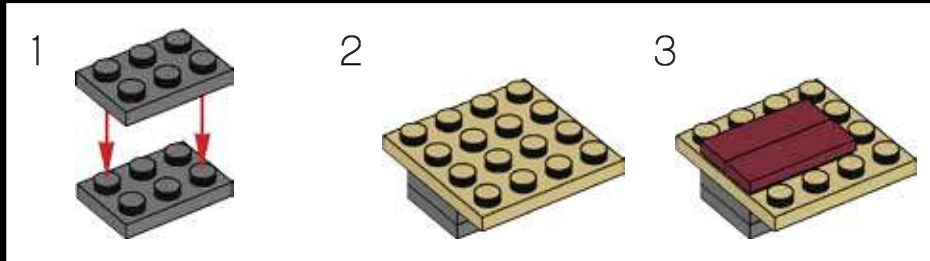

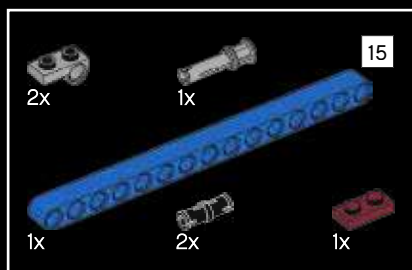

113

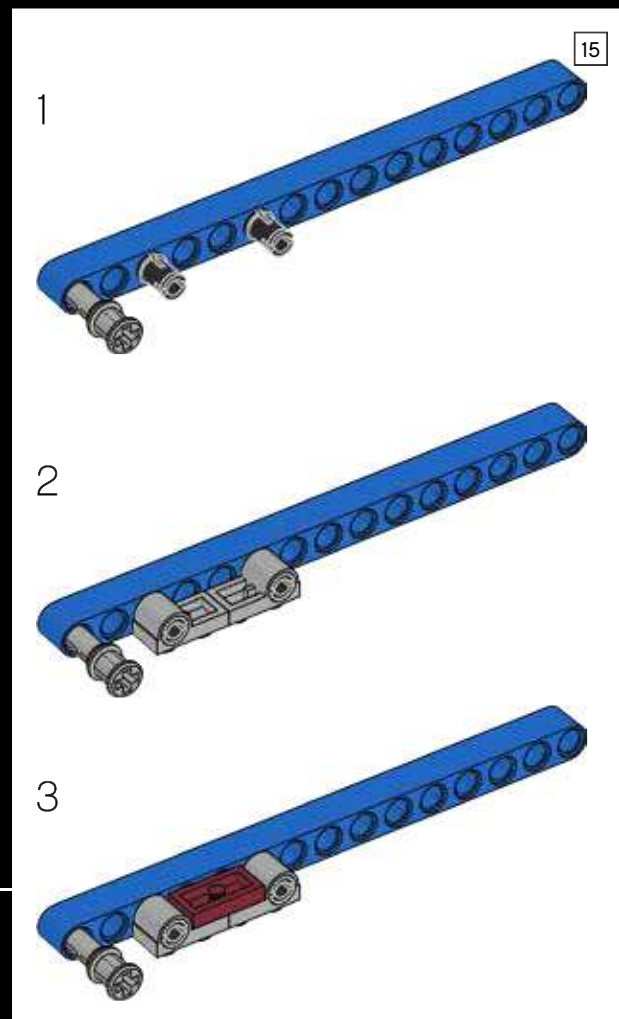
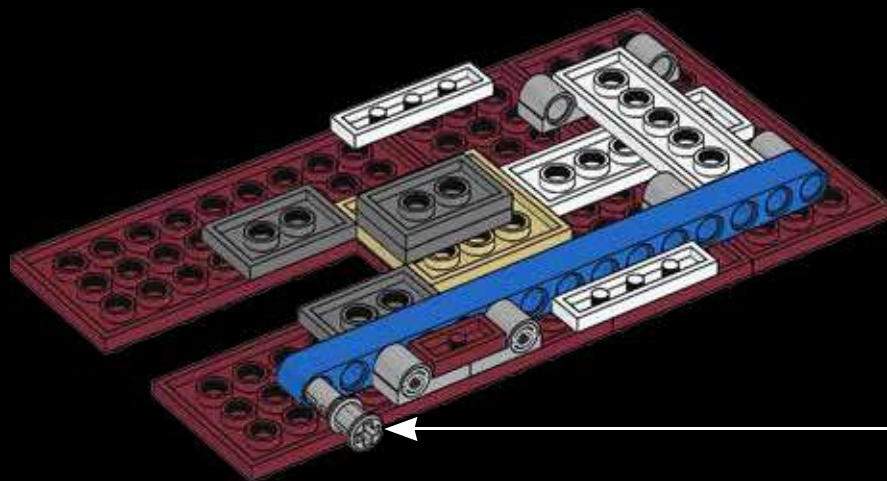

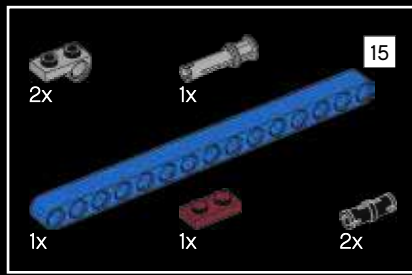

114

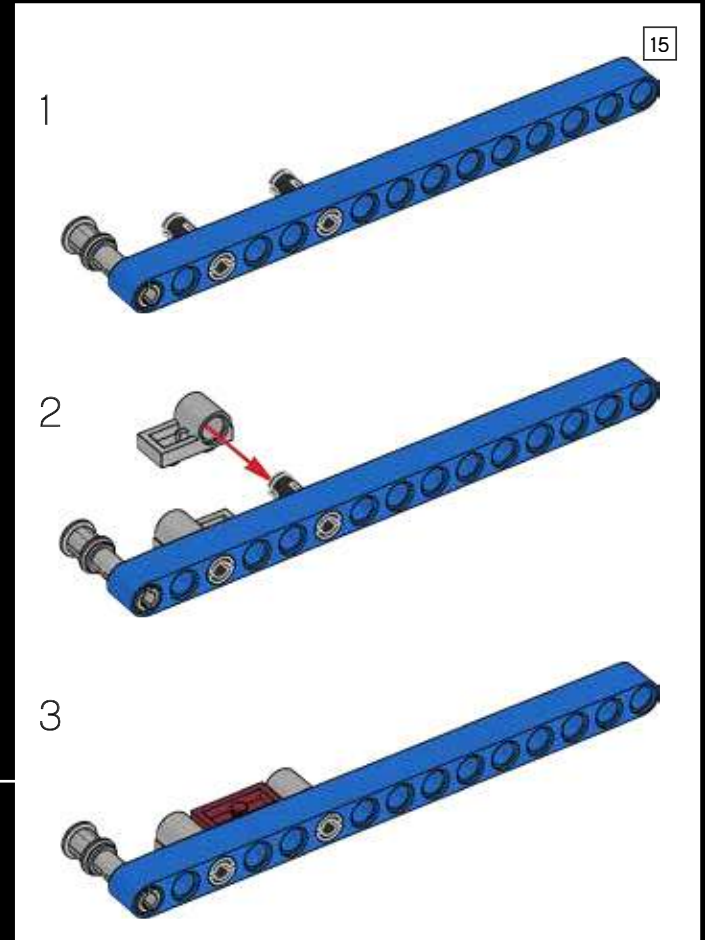
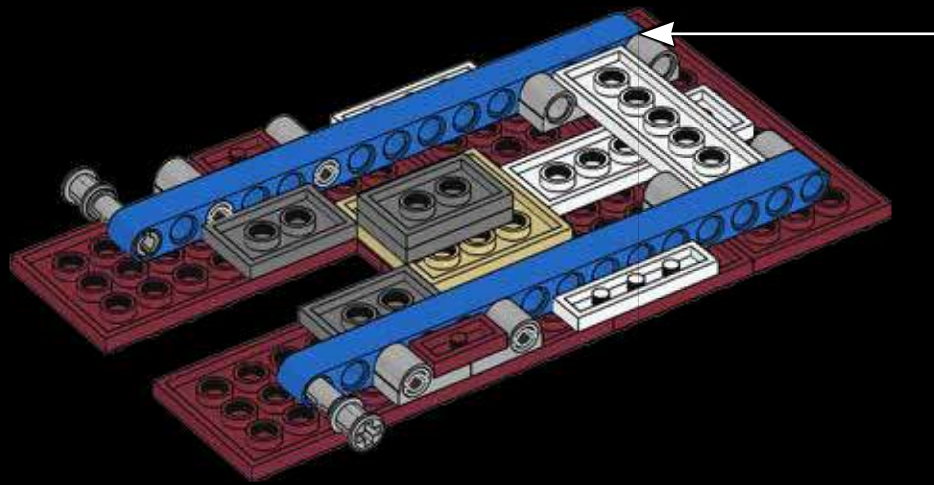



115

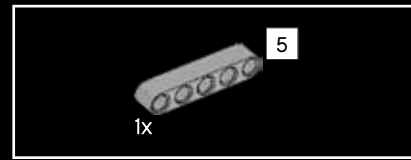
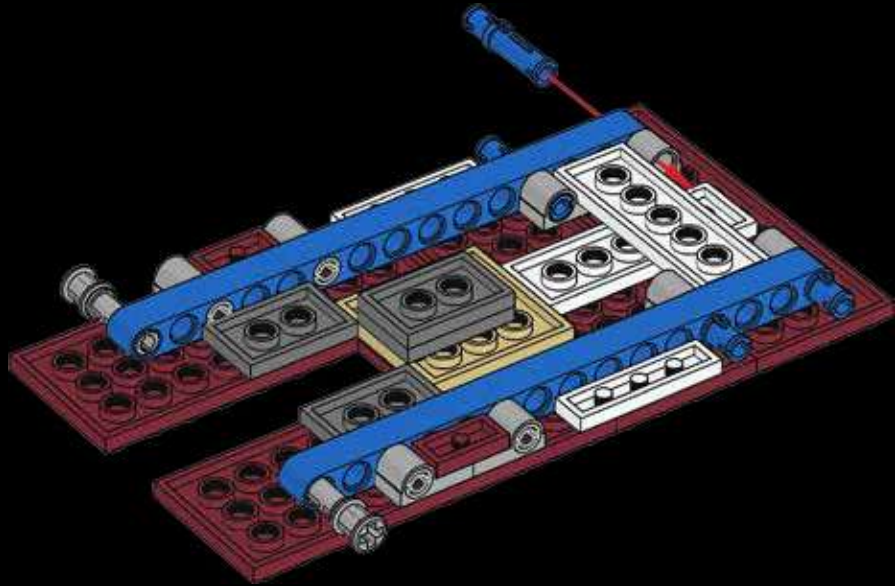

116

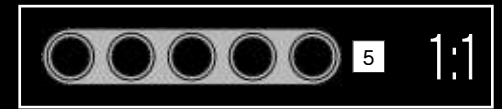
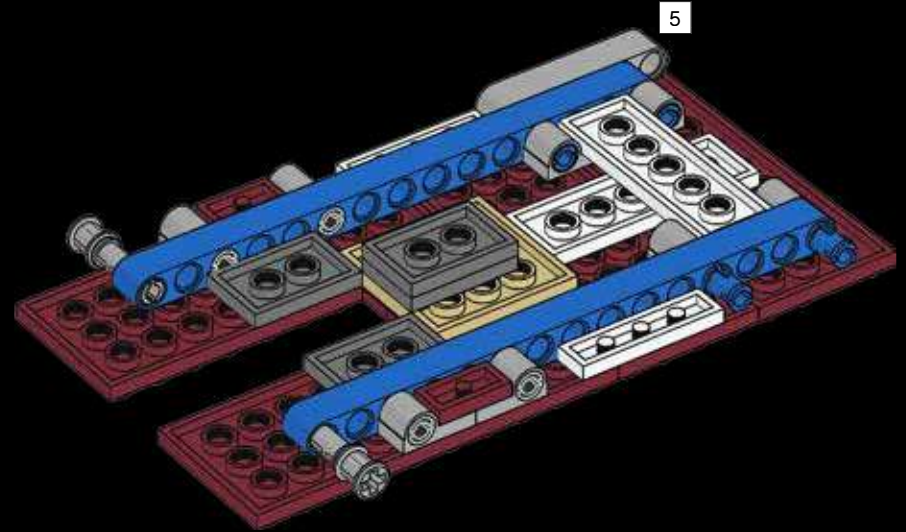



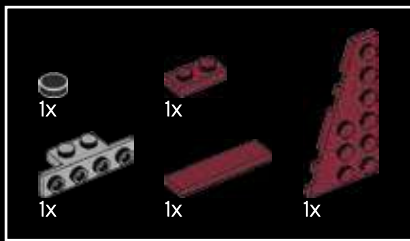

117

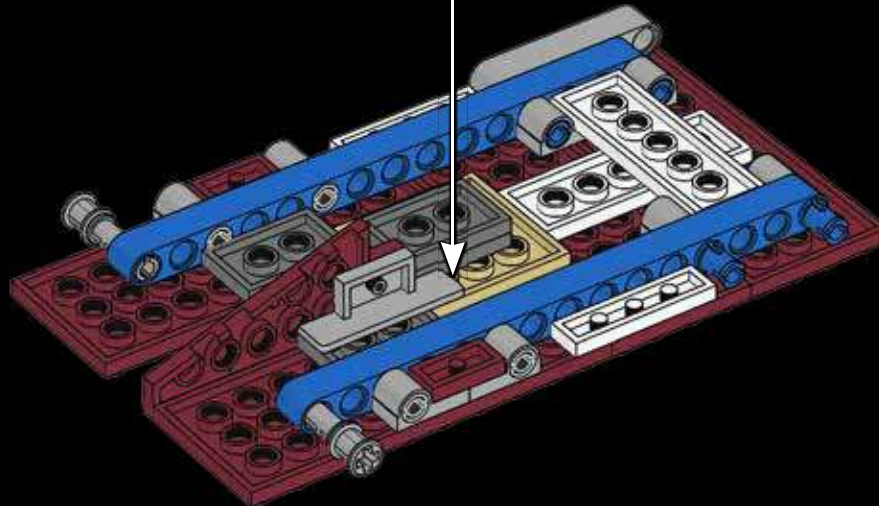
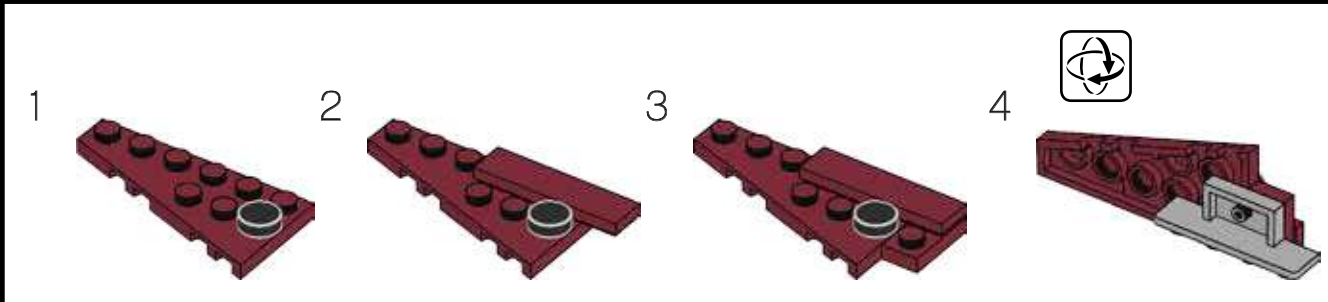

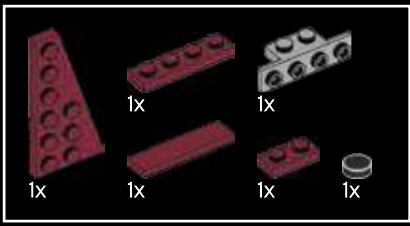

118

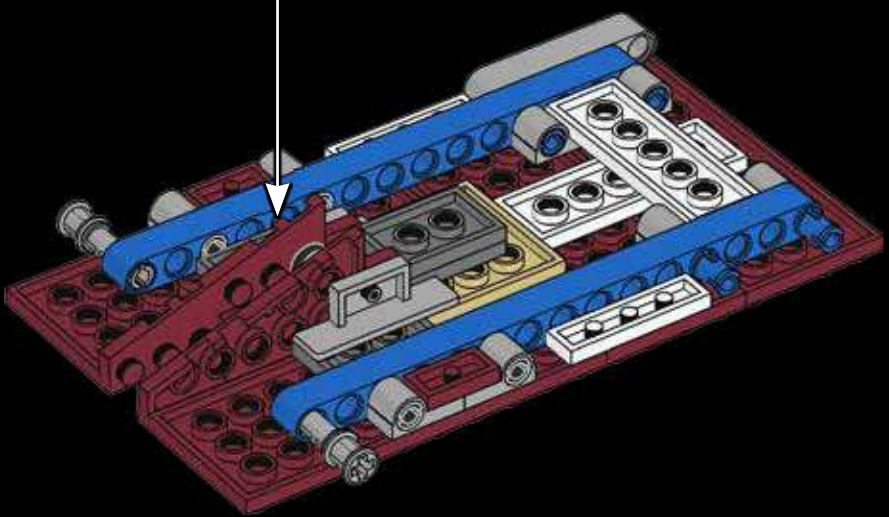
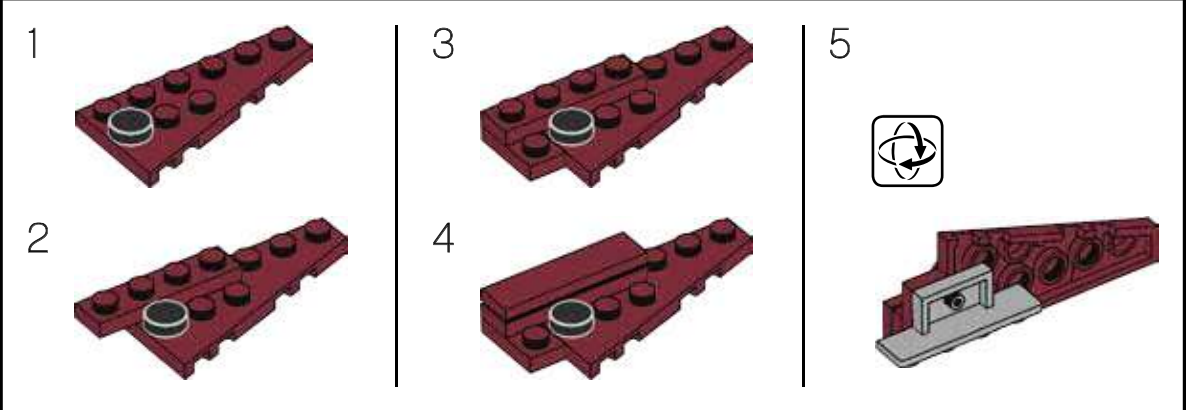

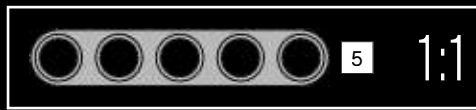
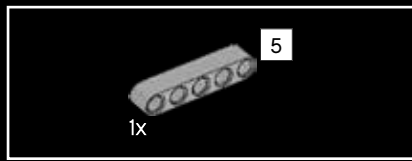

119

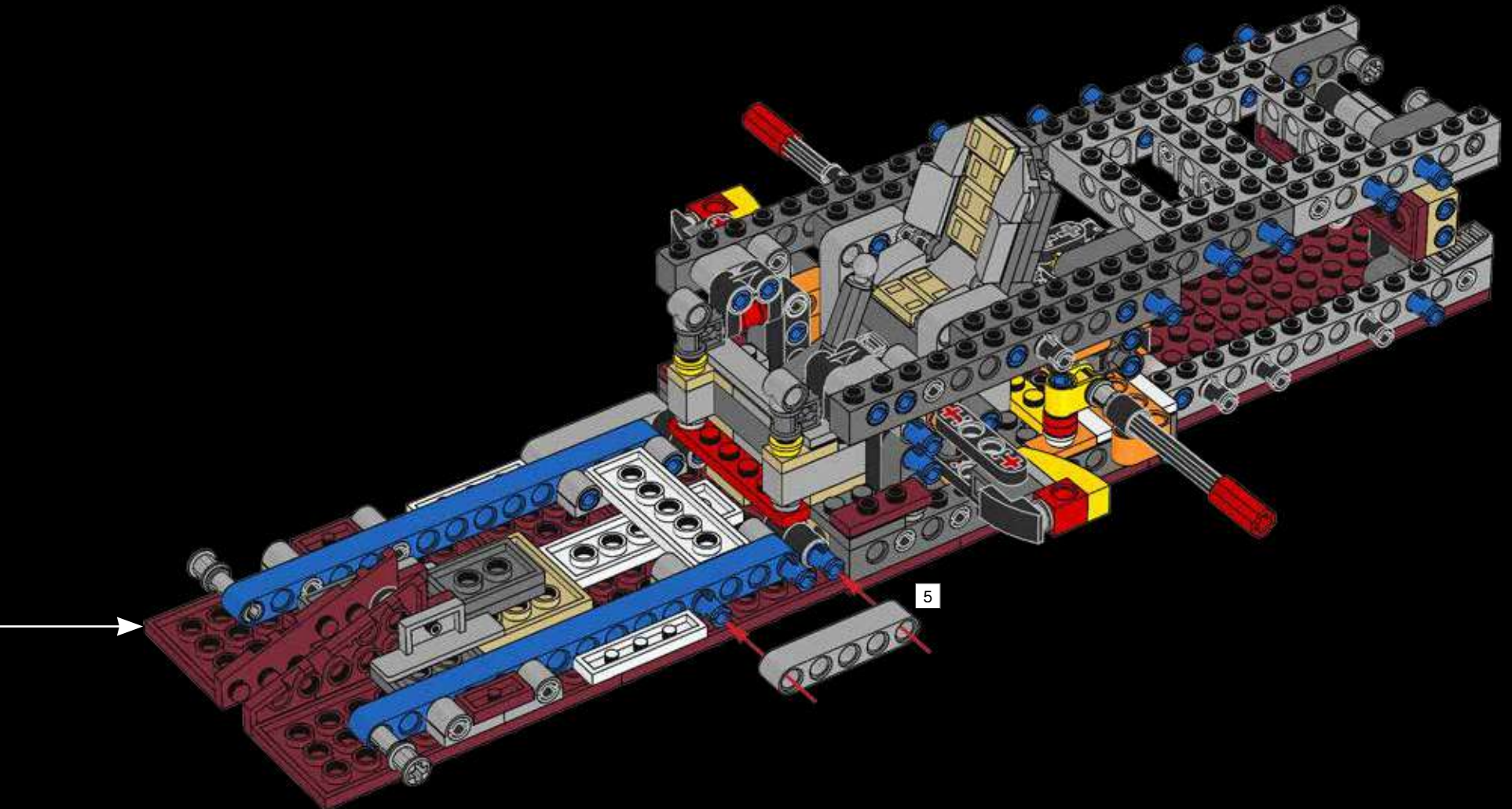



120



121

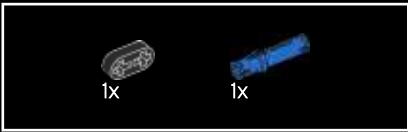

122



123

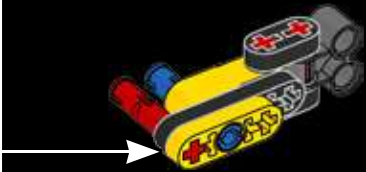
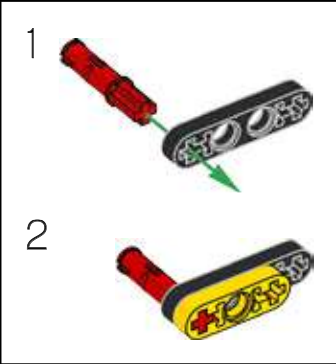

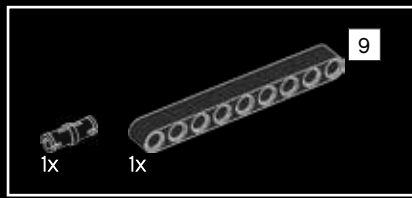

124

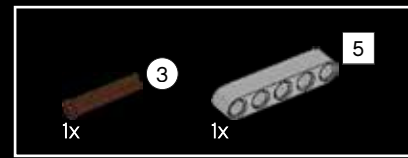
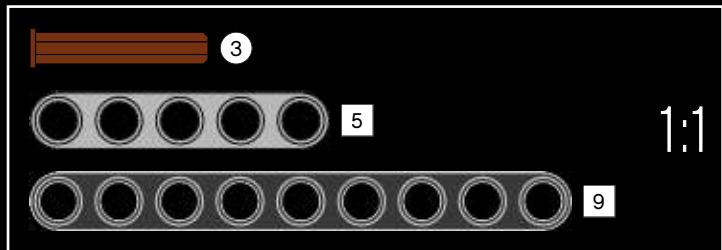
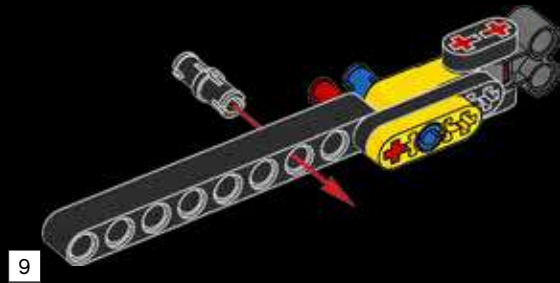

125

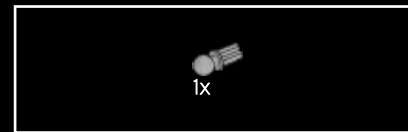
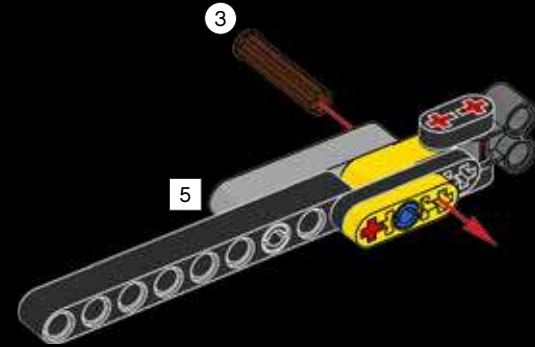

126

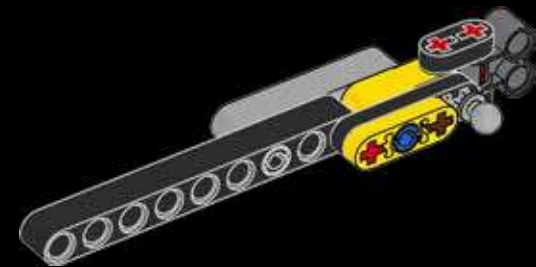

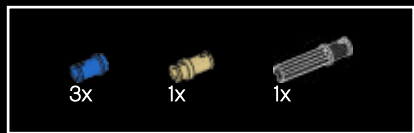

127

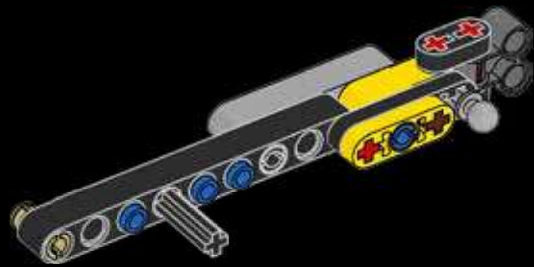

2x

128

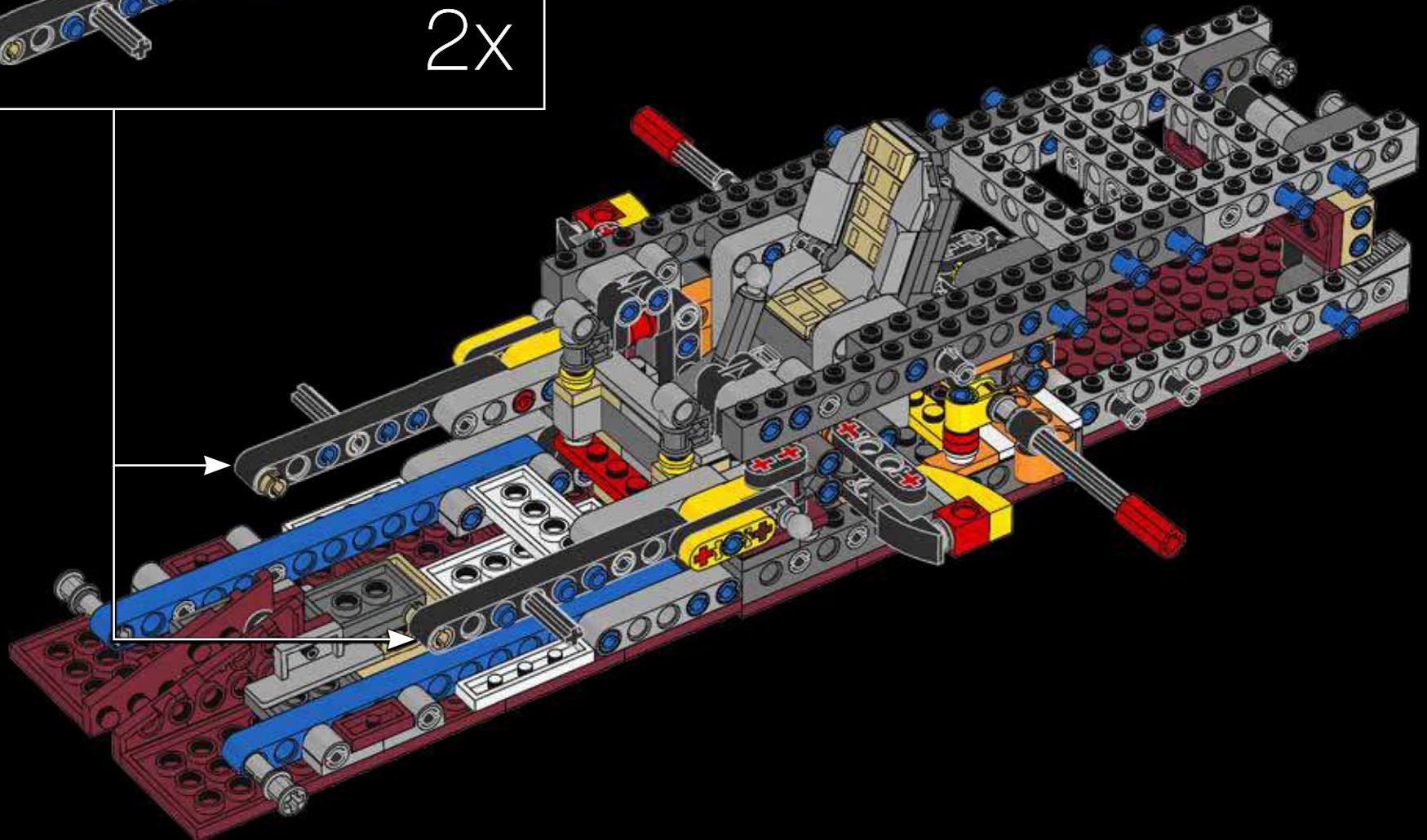

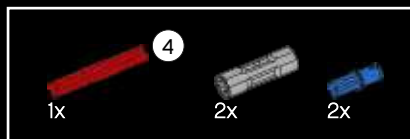

129

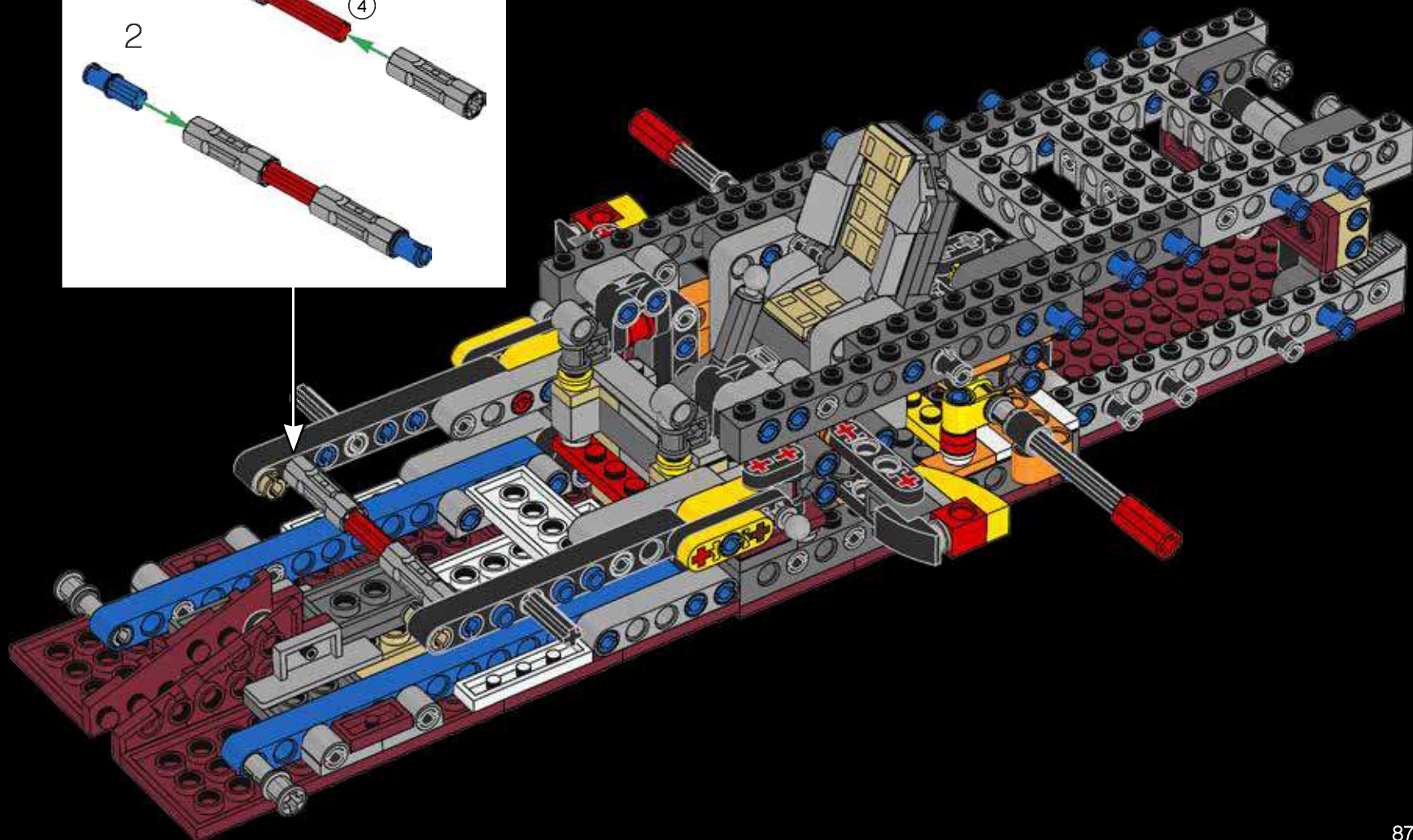
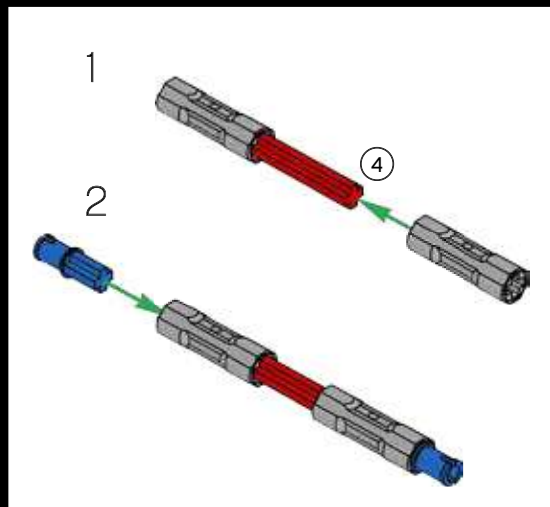

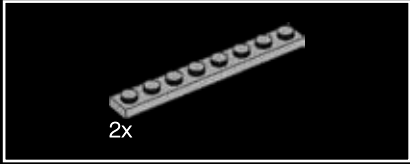
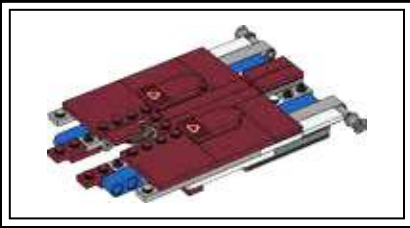

130

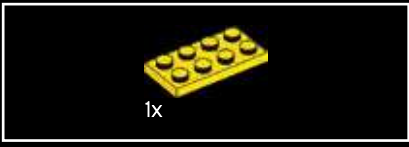

131

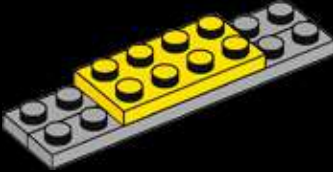

132

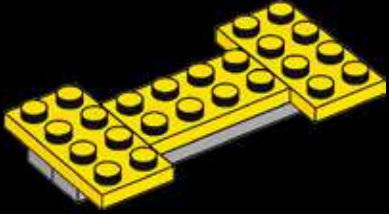





133



134

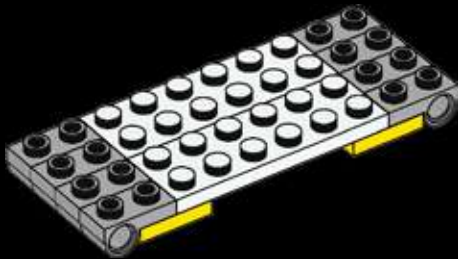

135

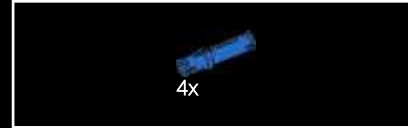
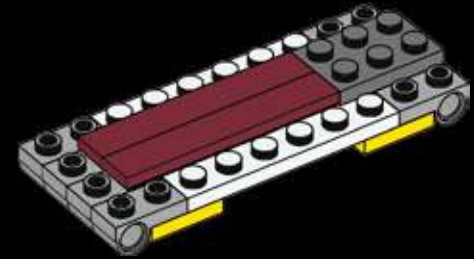

136

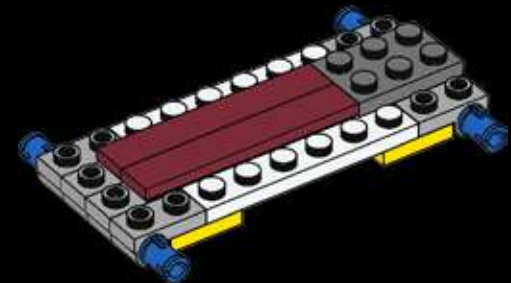

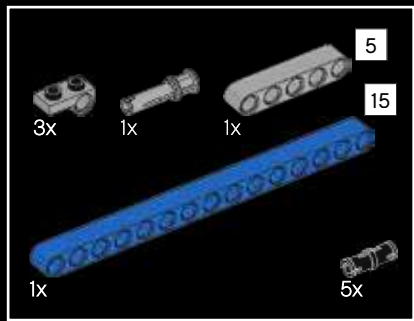

137

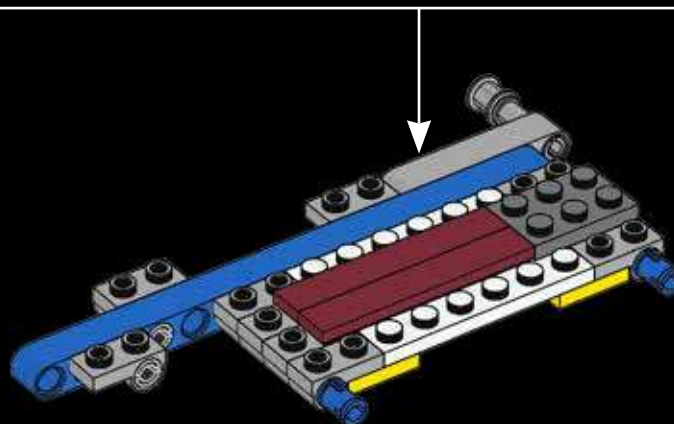
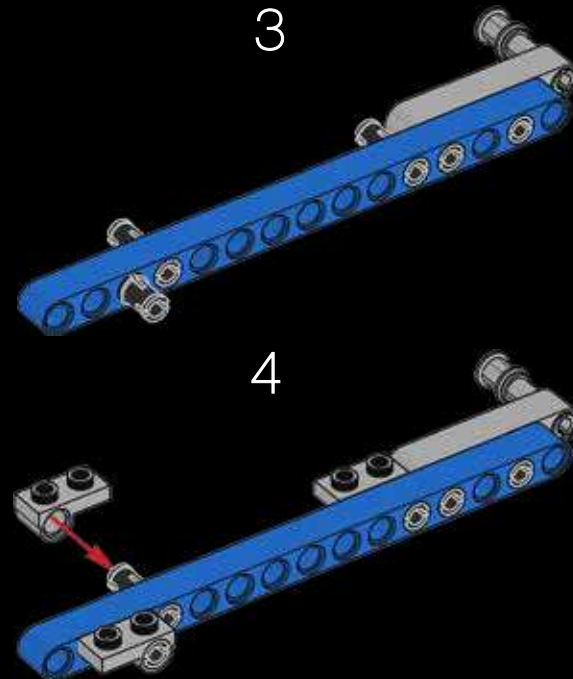
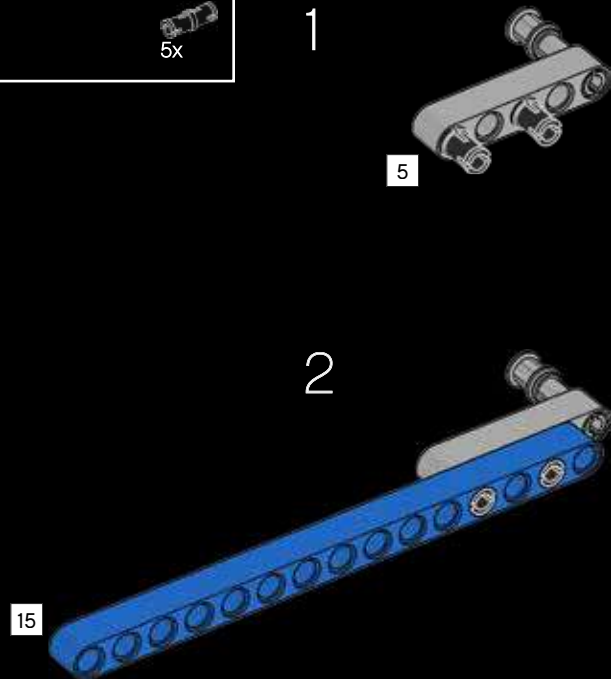

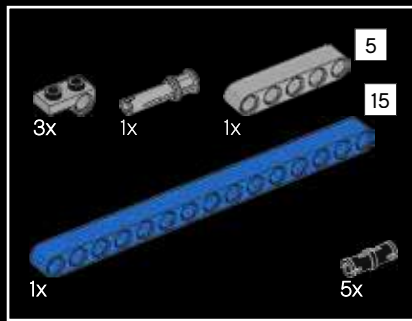

138

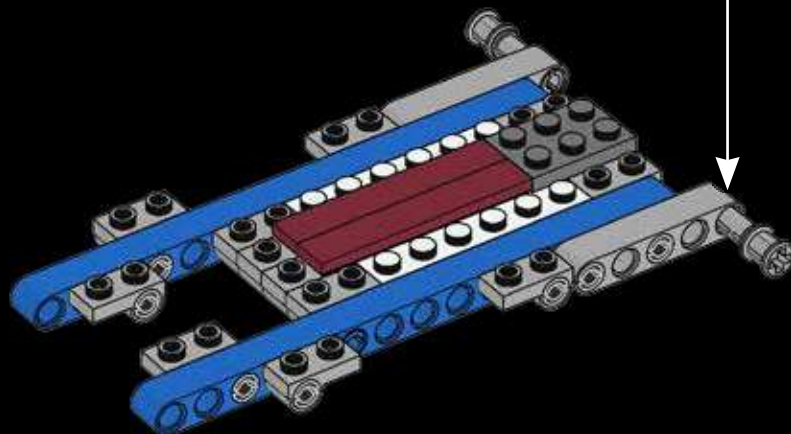
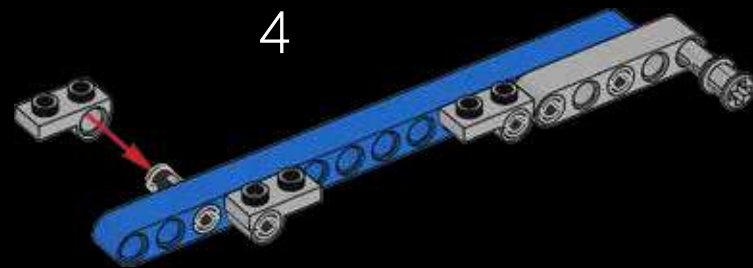
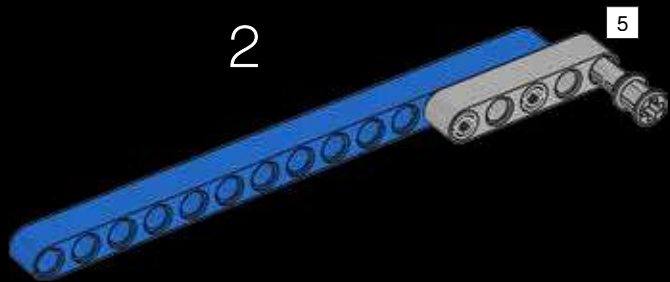
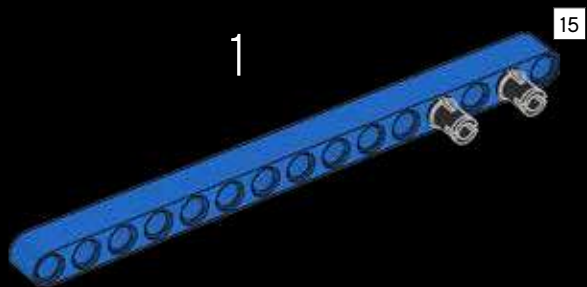

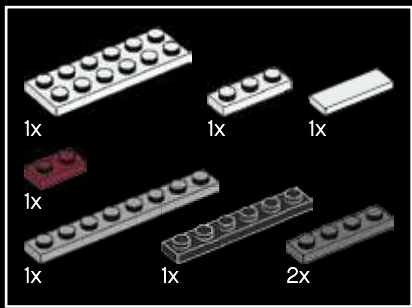

139

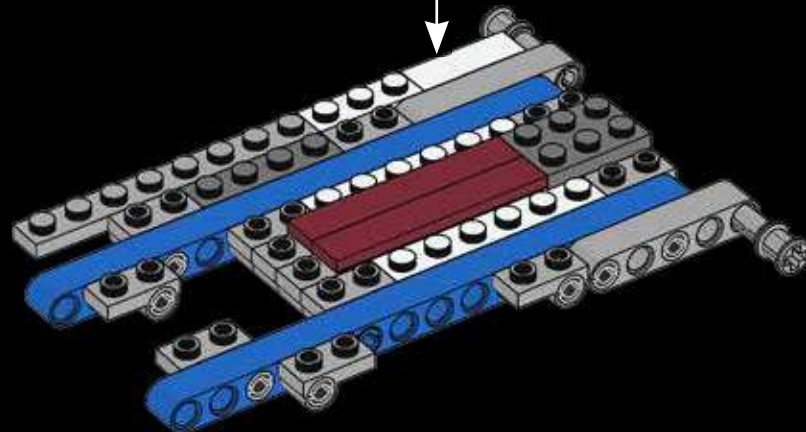
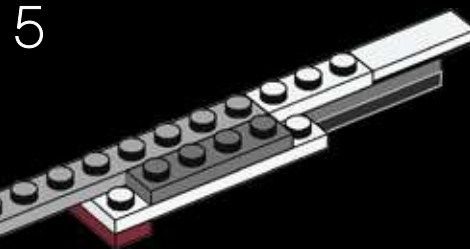
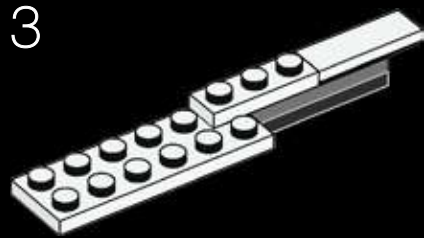
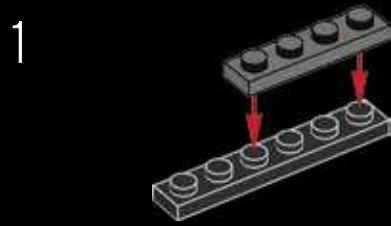



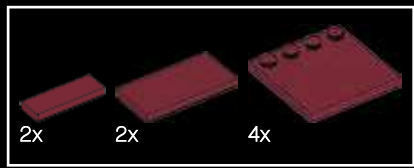

141

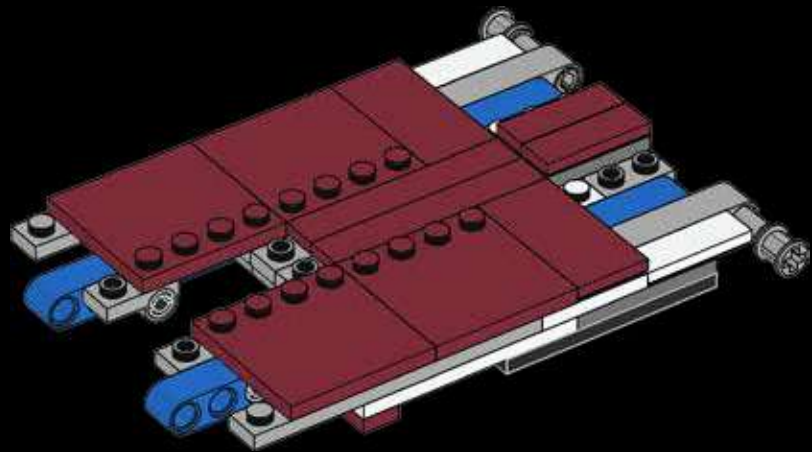

142

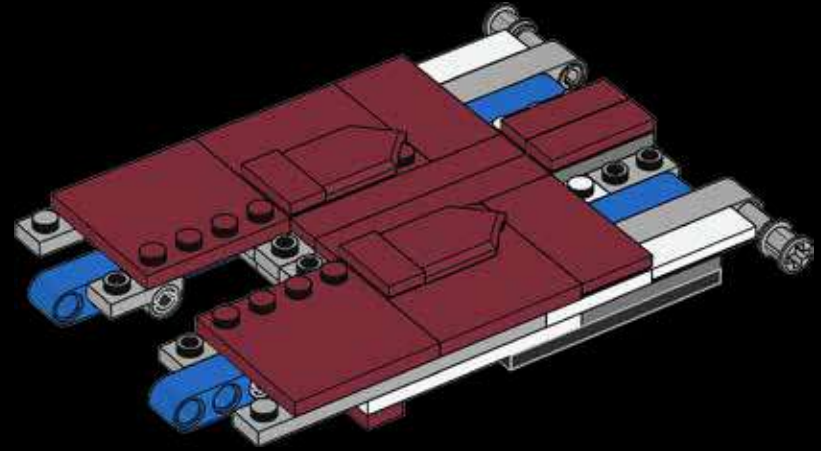

143

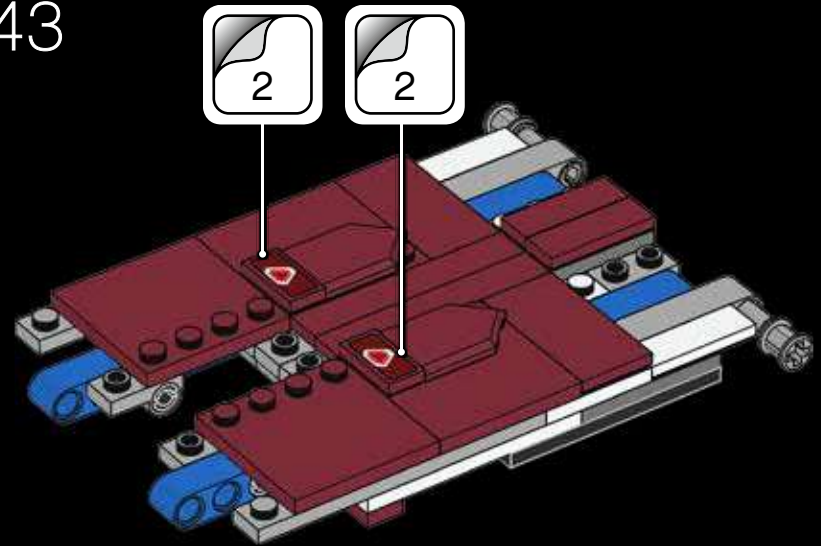



144

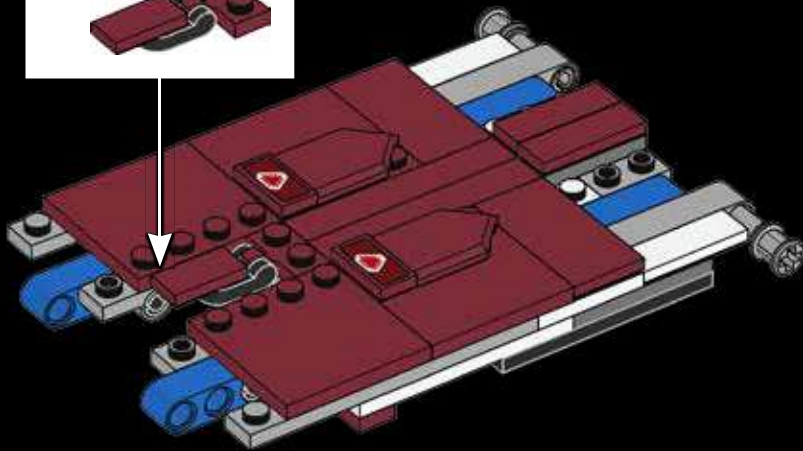
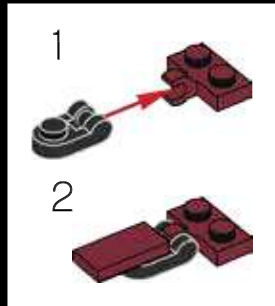

145

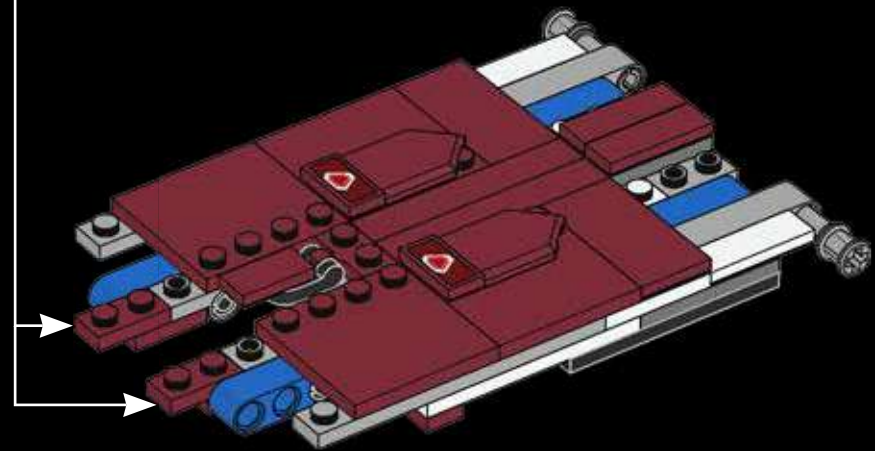
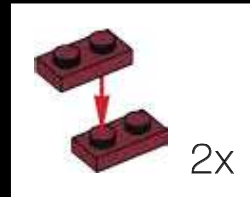

146

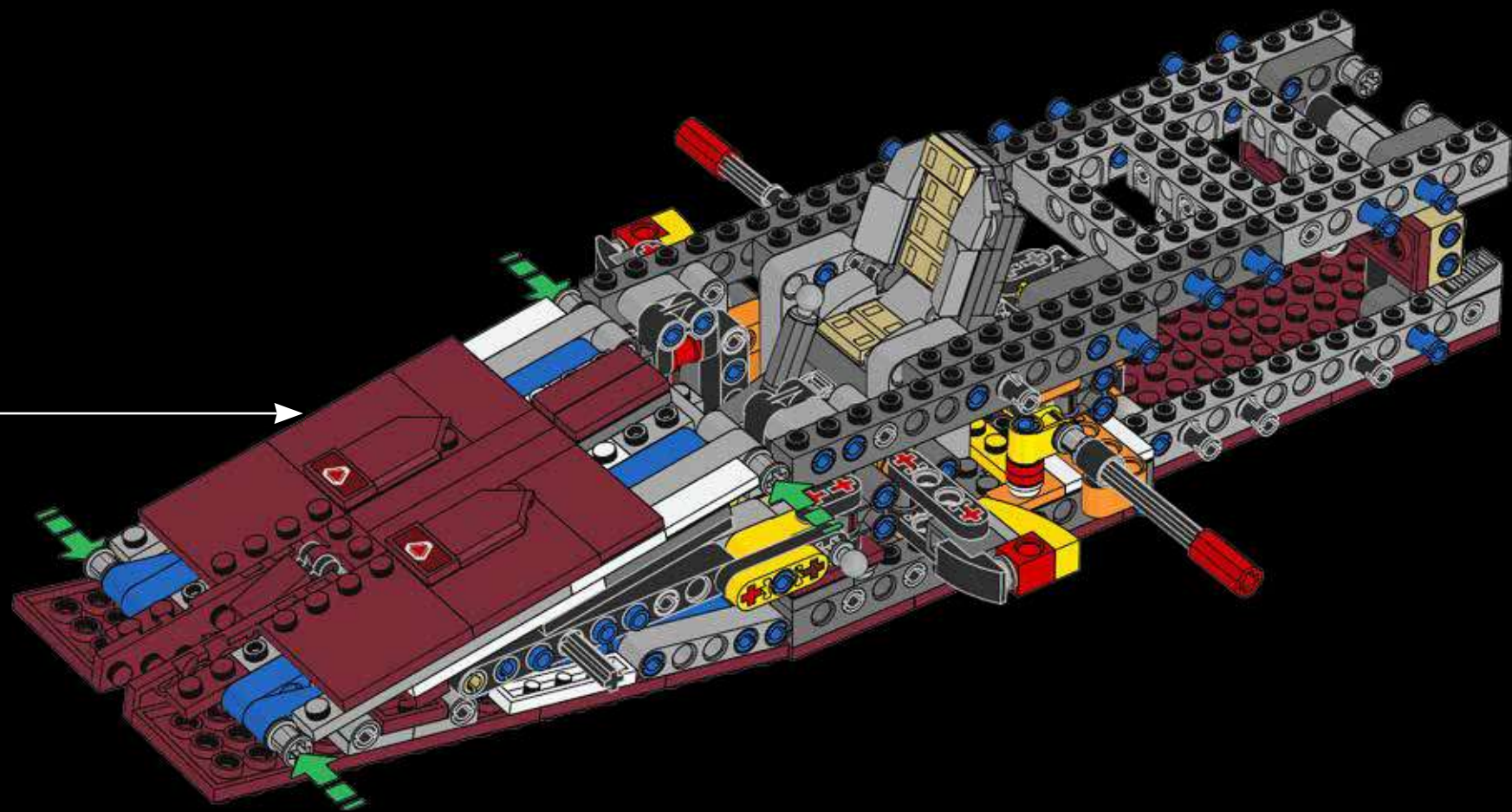



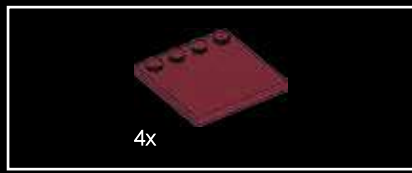

147

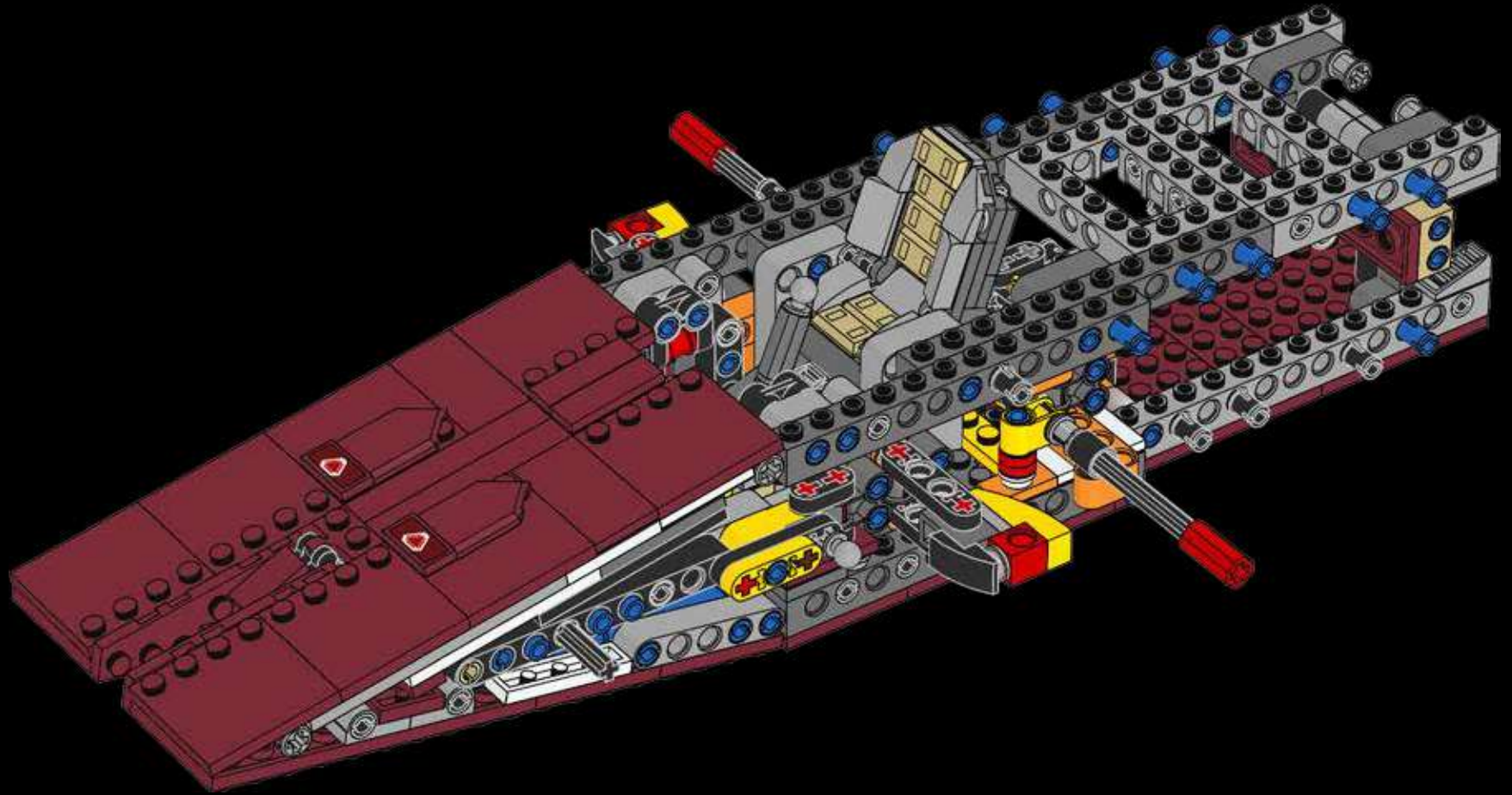



4x

148

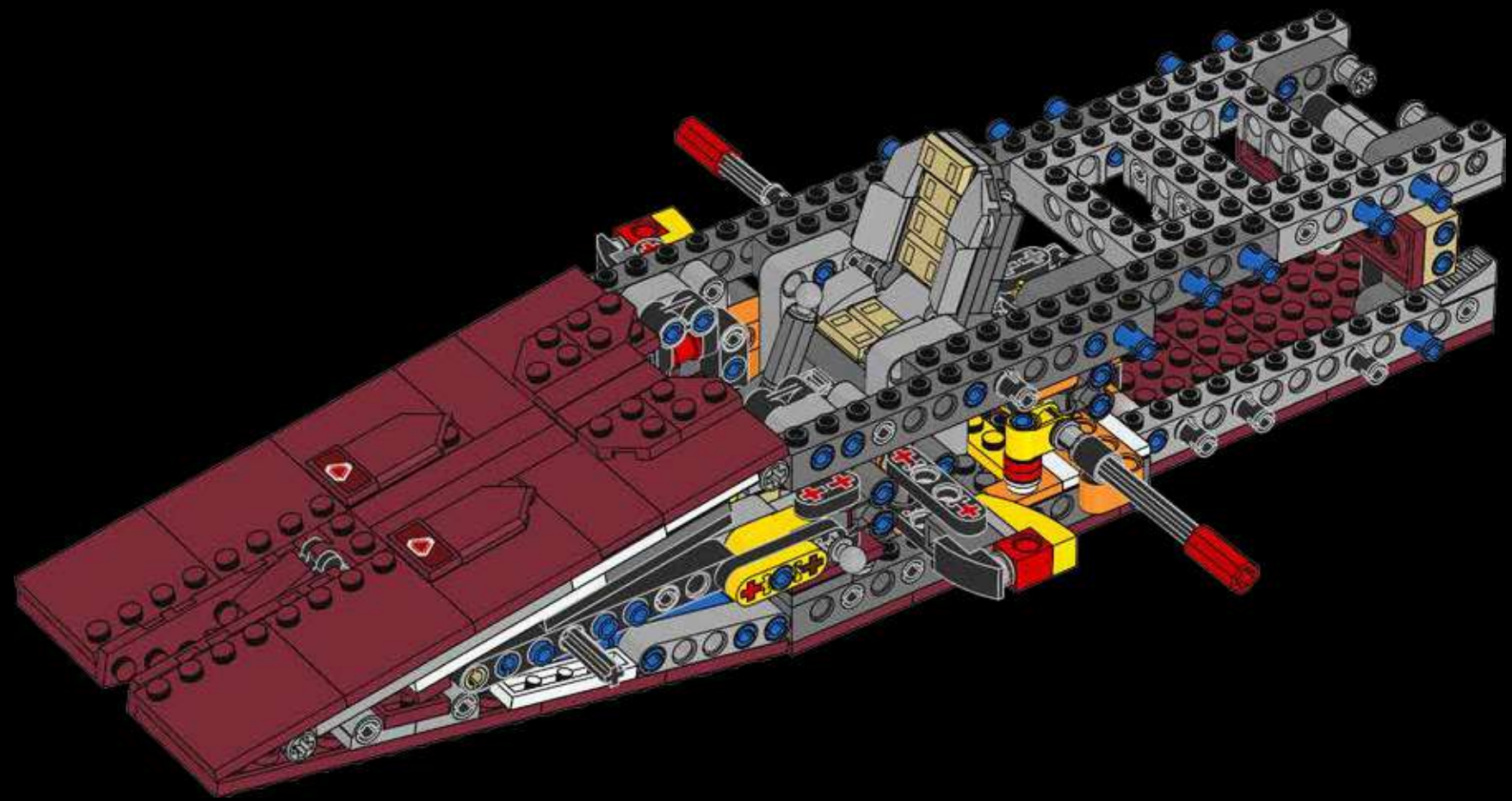

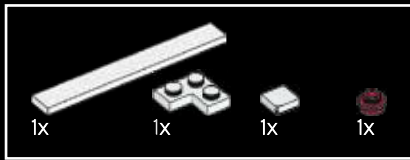
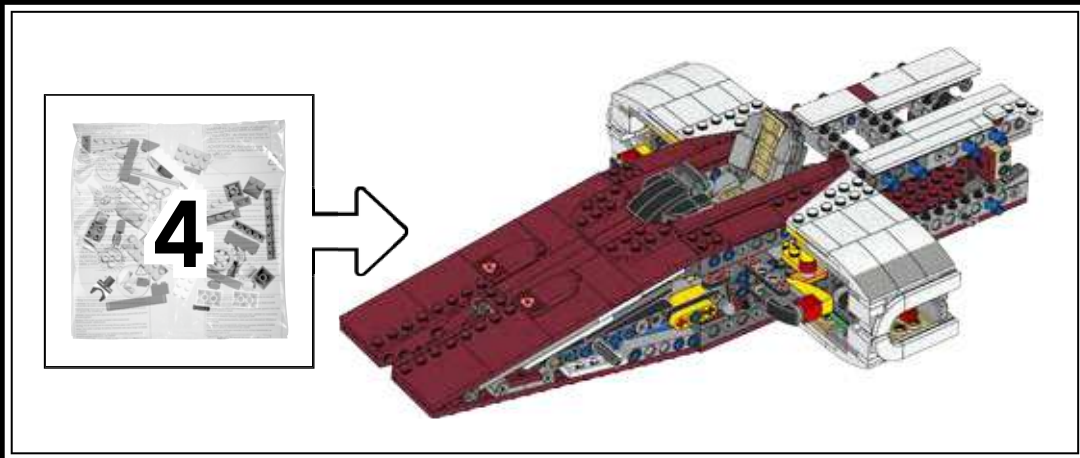

149

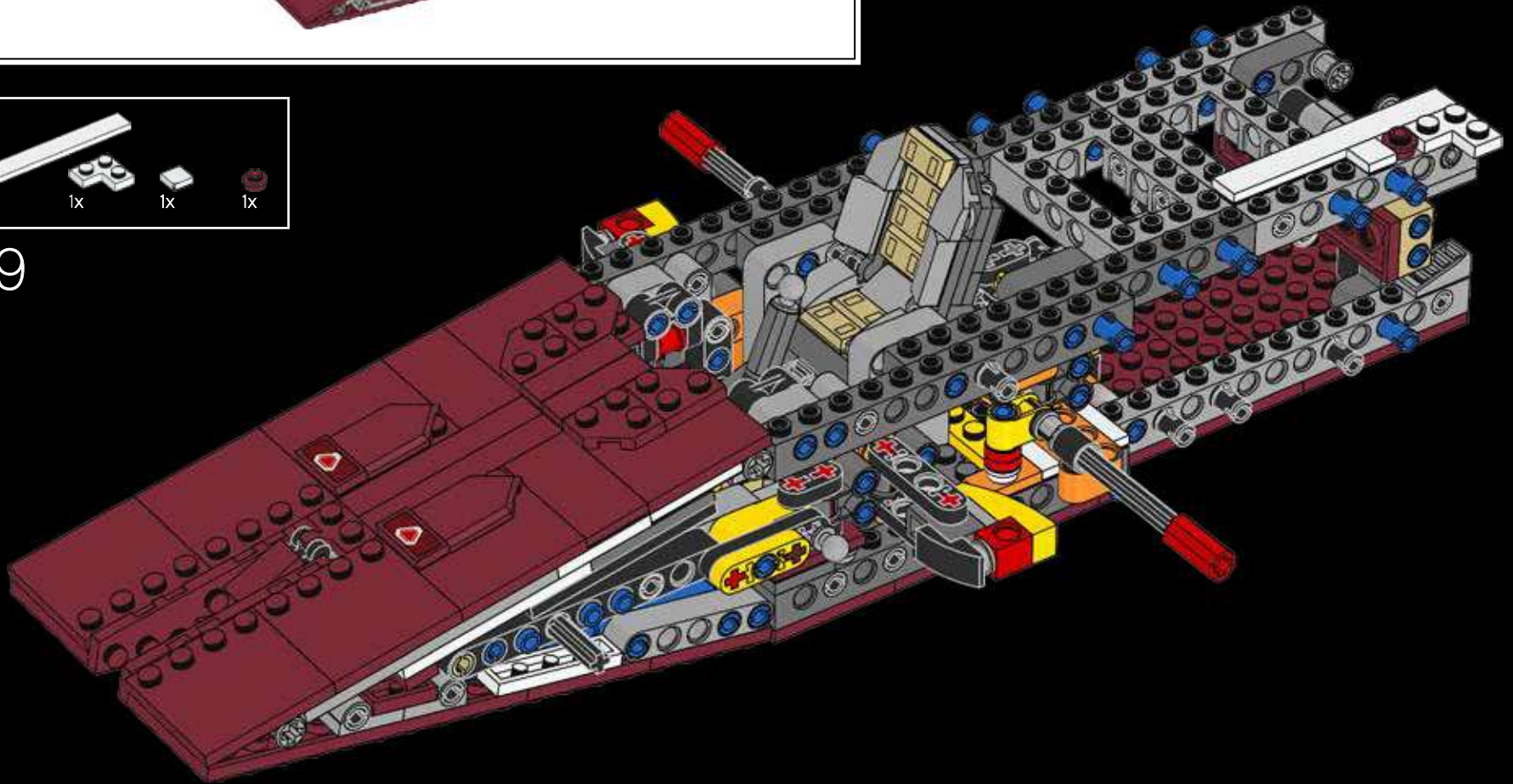

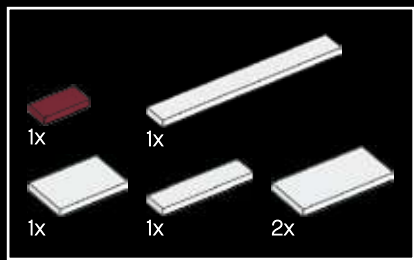

150

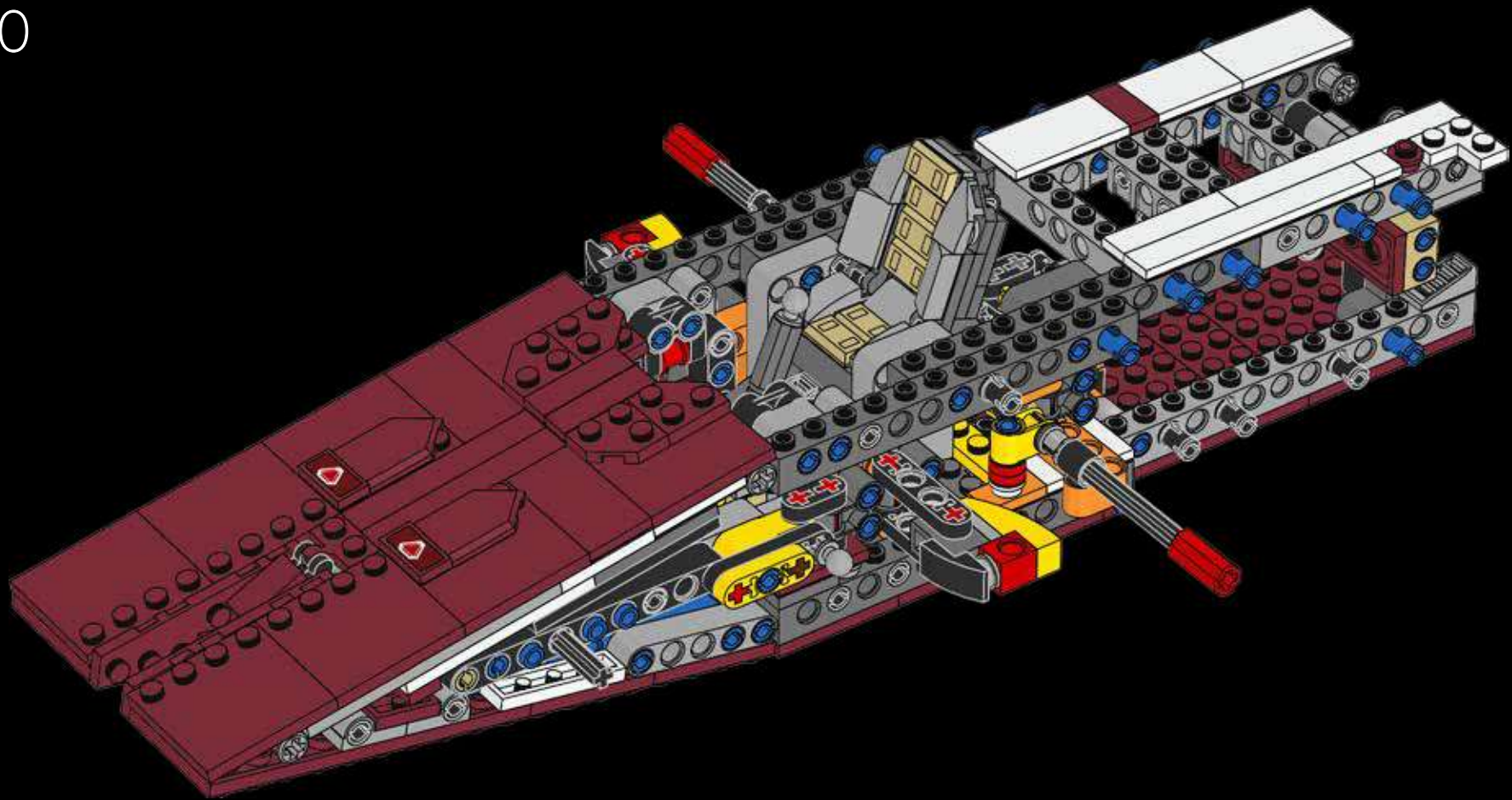

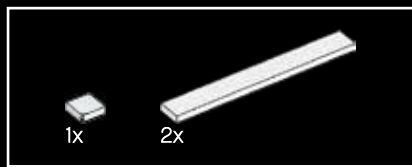

151

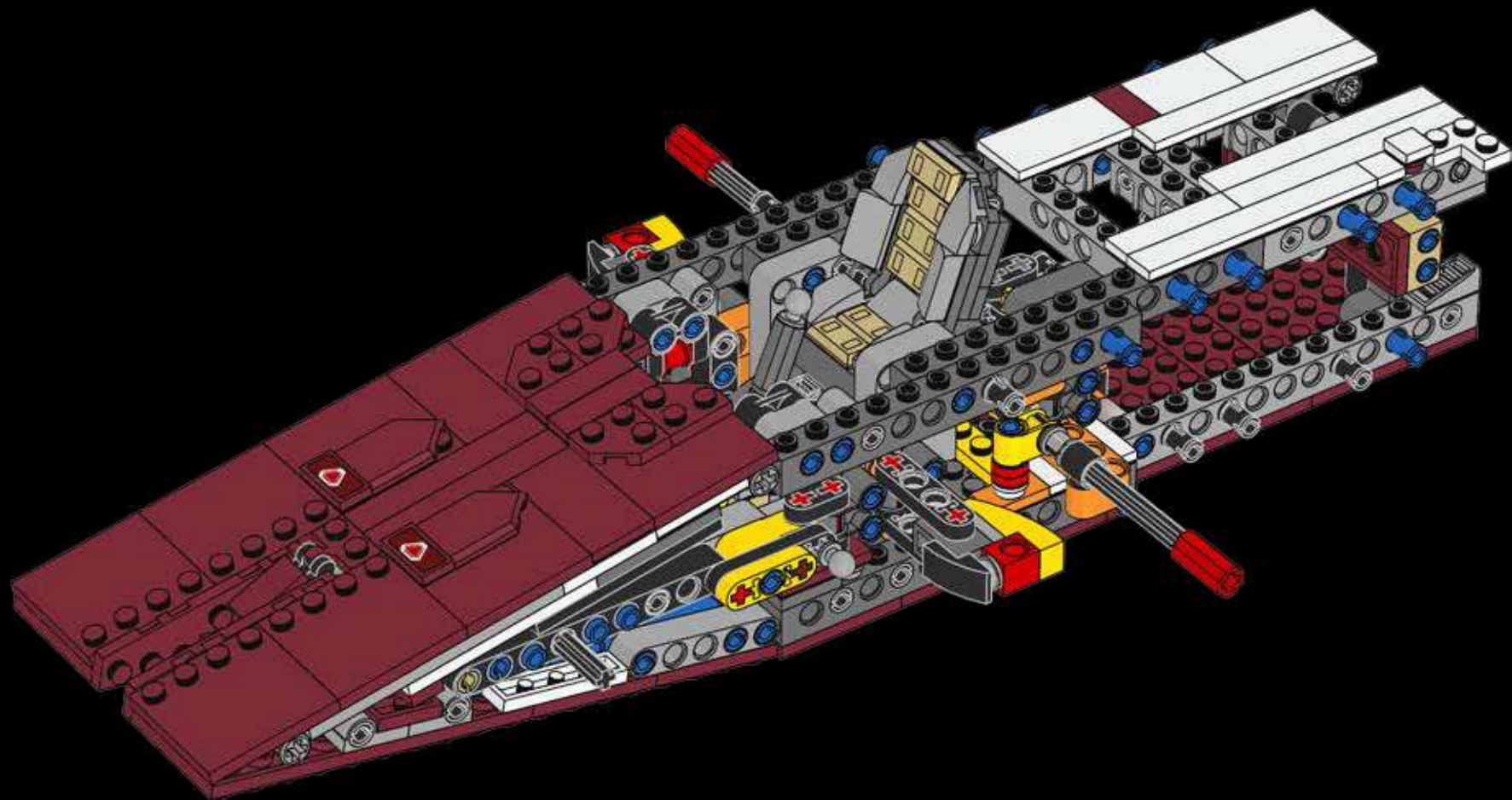

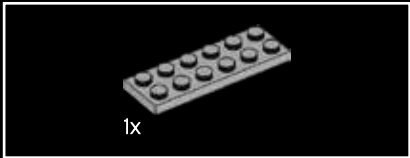
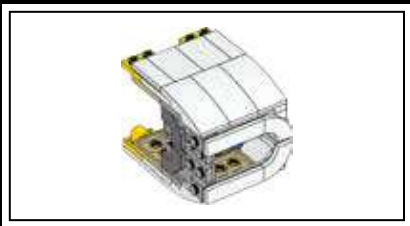

152



153



154

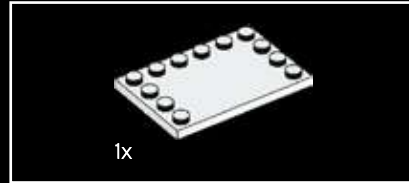

155

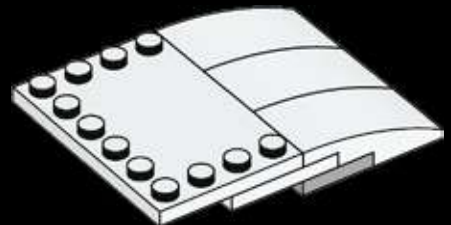

156

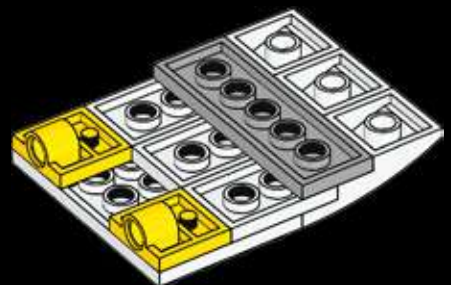



157

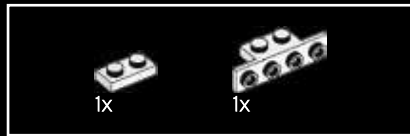
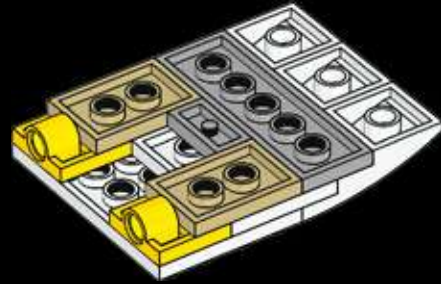

158

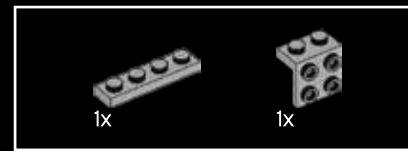
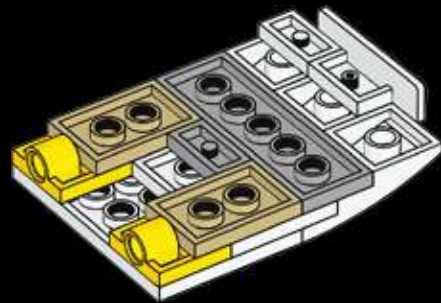

159

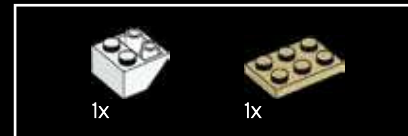
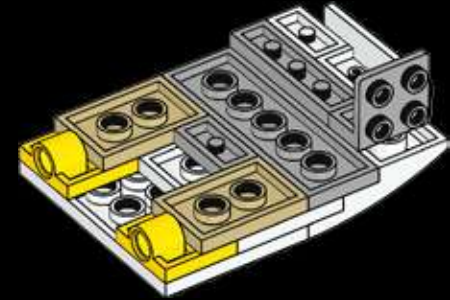

160

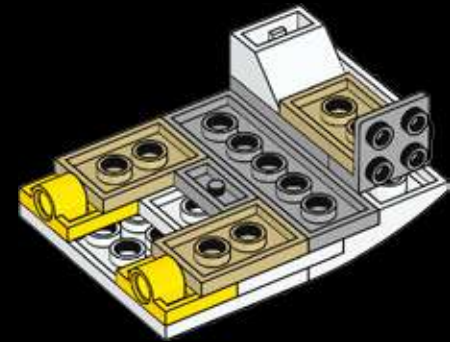

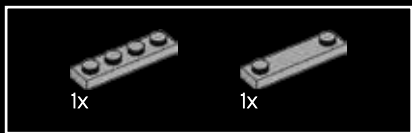

161

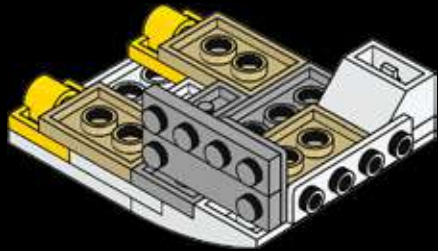

162

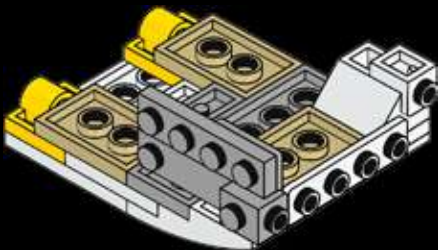

163

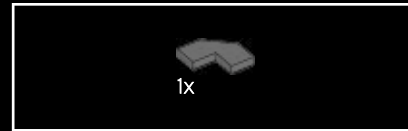
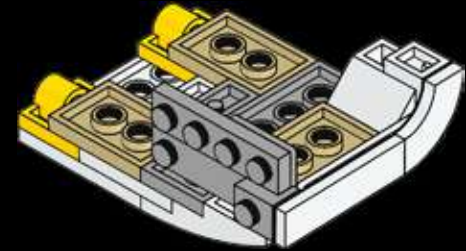

164

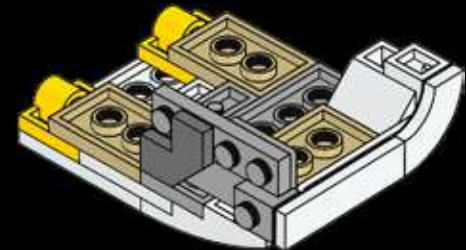



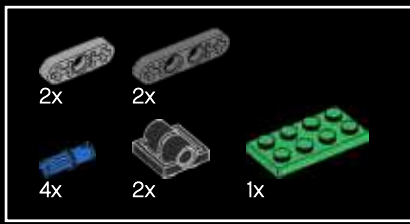

165

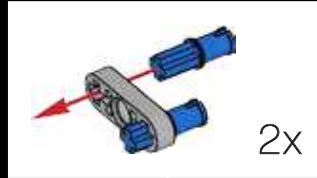

1



2

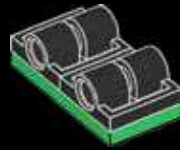

3

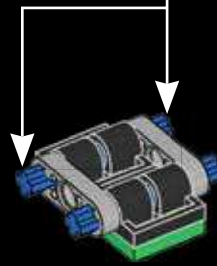

4

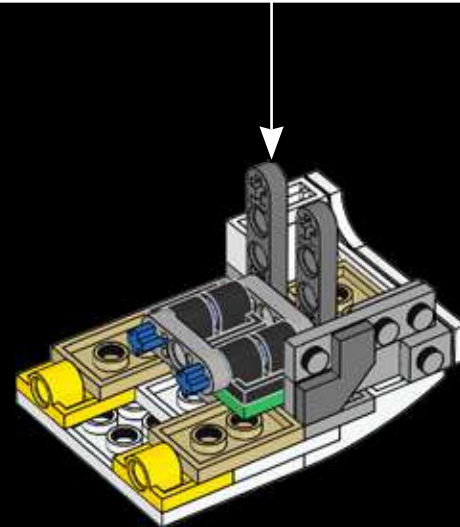
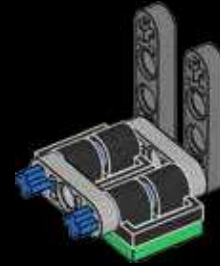



166

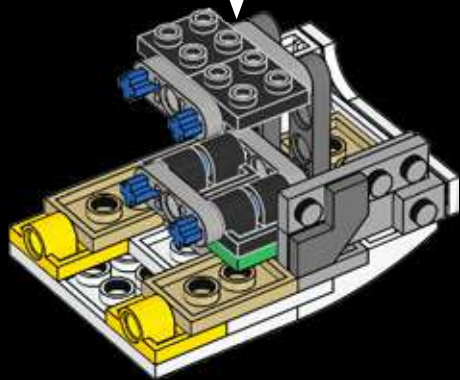
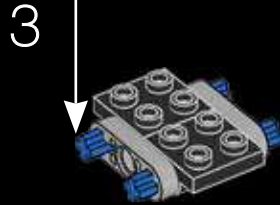
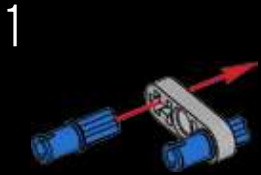
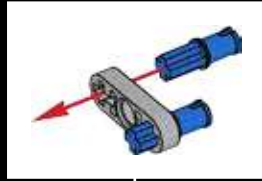

167

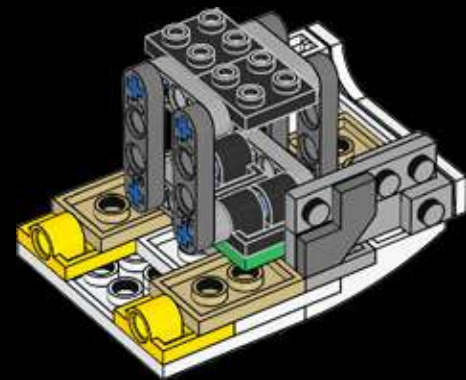

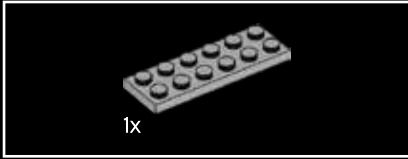
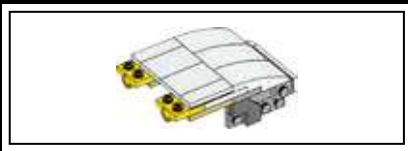

168



169



170

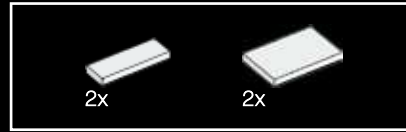

171



172

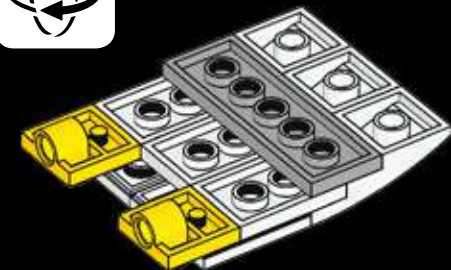



173

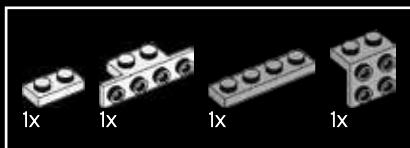
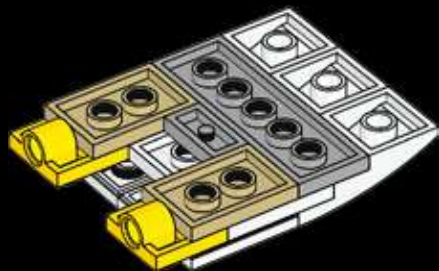

174

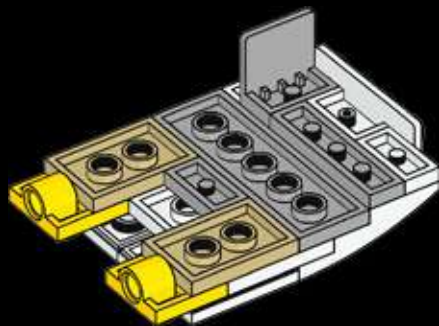

175

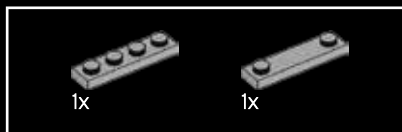
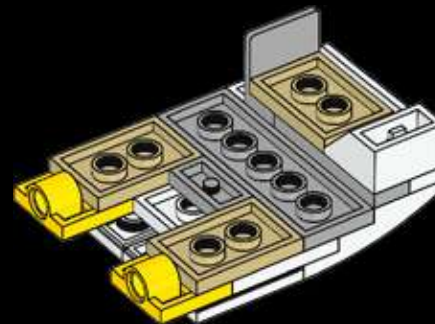

176

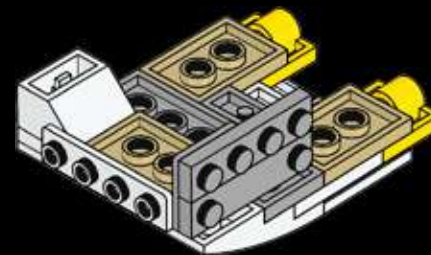



177

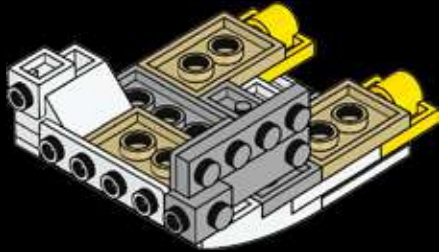

178

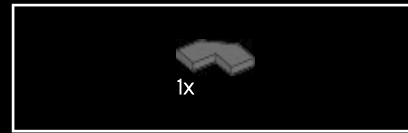
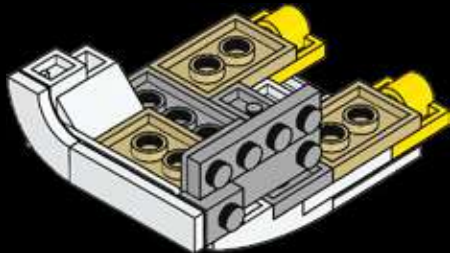

179

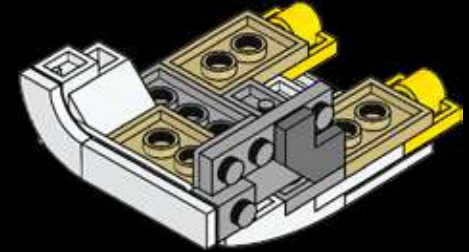

180

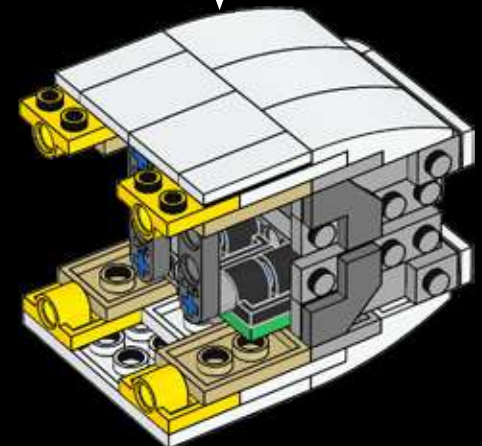

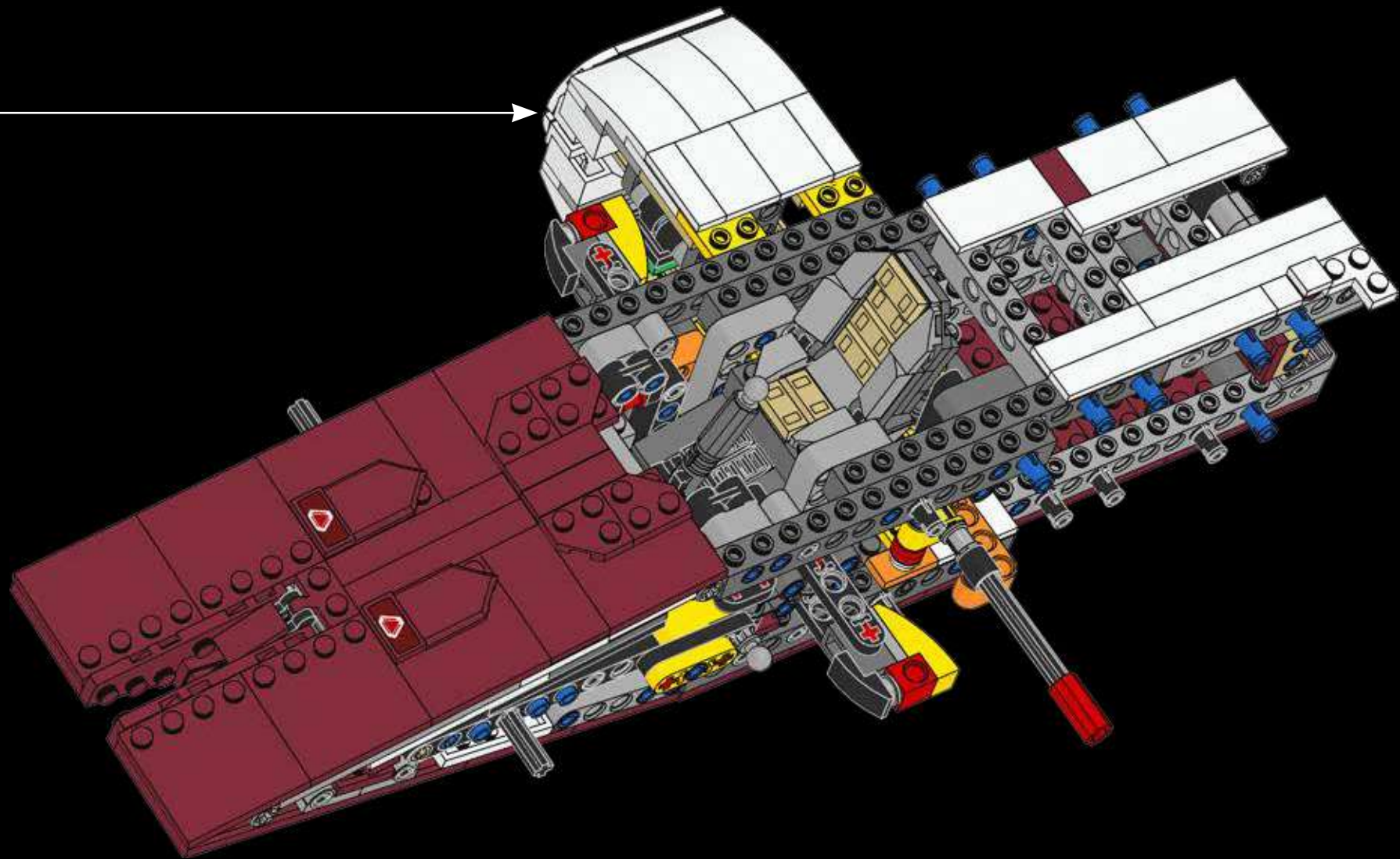

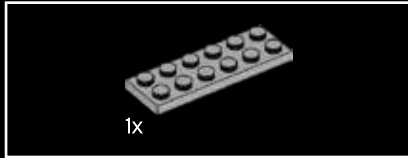
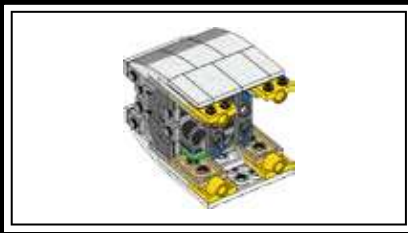

182



183



184

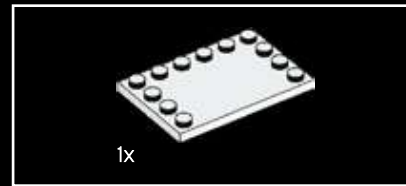

185

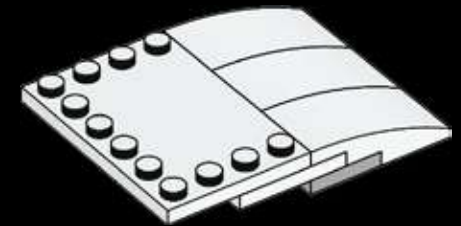



186

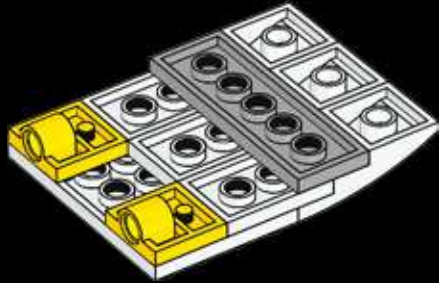

187

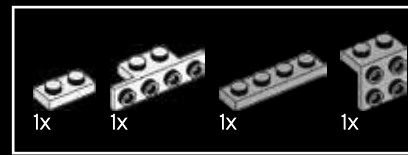
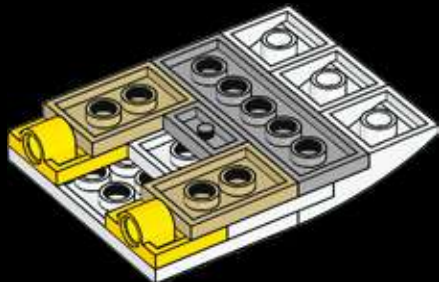

188

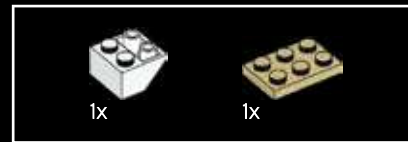
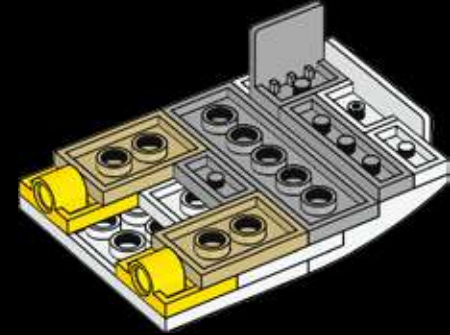

189

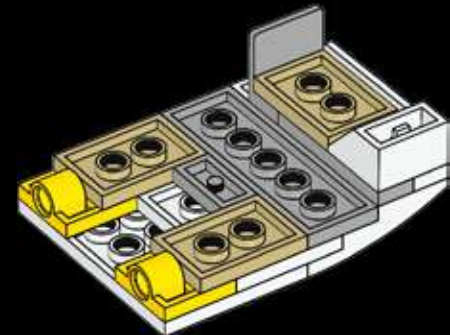



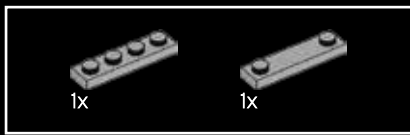

190

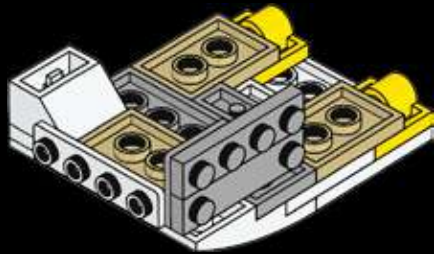

191

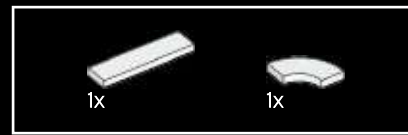
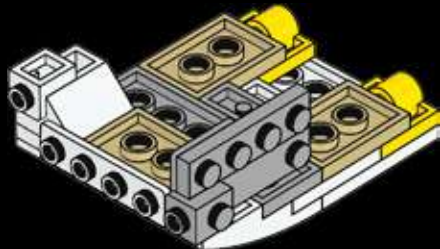

192

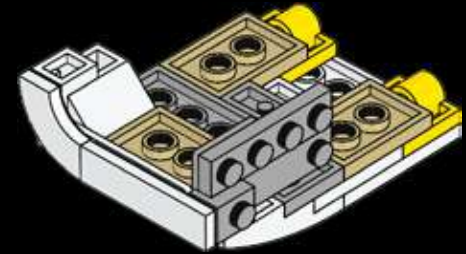

193

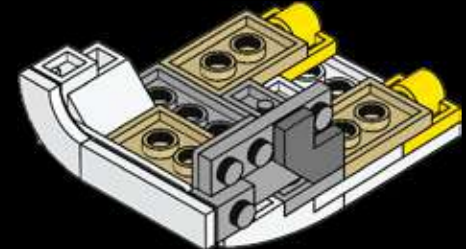

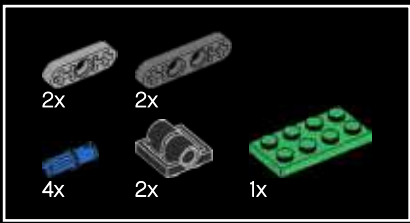

194

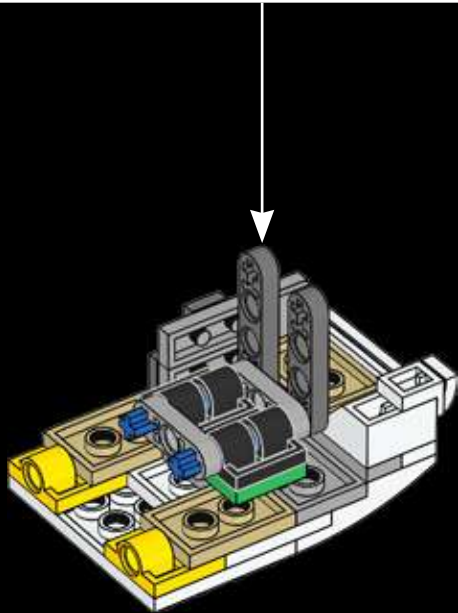
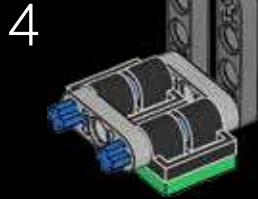
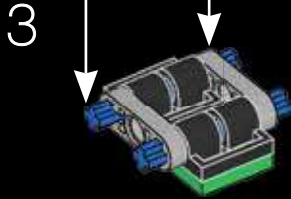
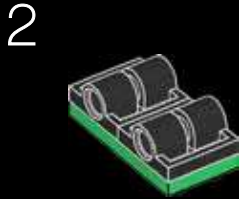
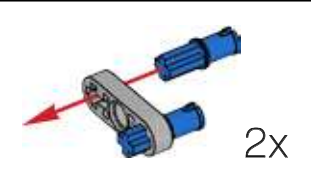



195

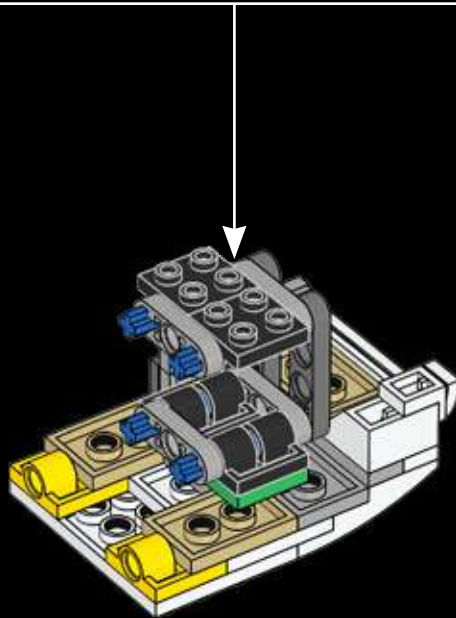
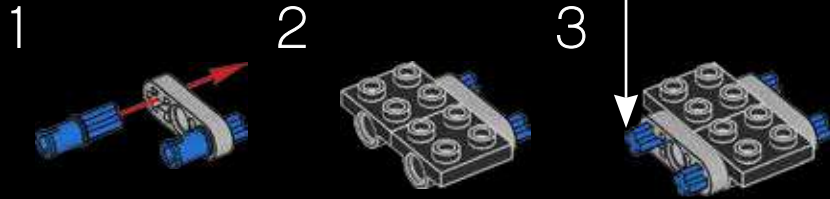
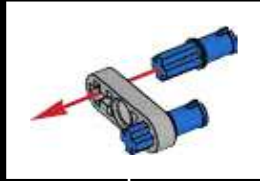

196

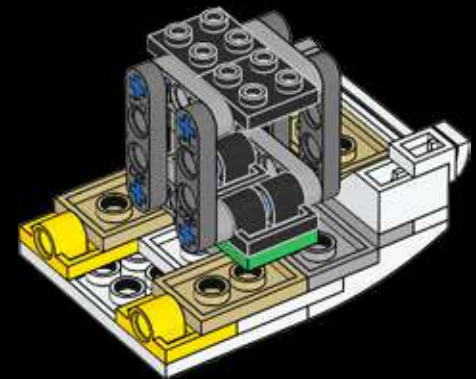

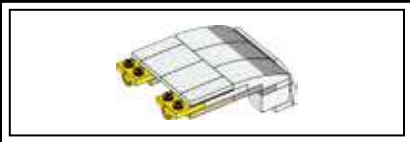

197

1x



3x

198



3x

199



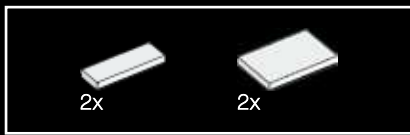

200



201

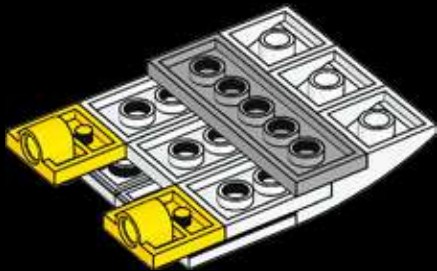

202

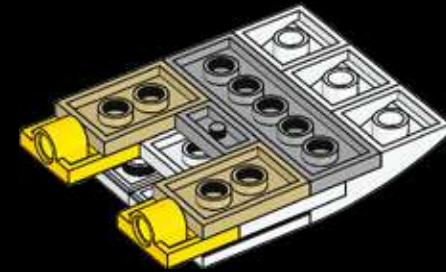

203

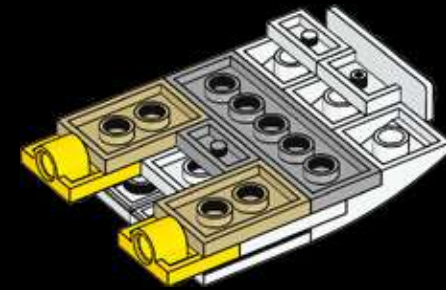

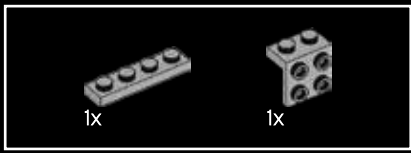

204

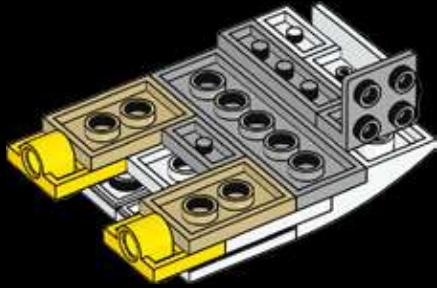

205

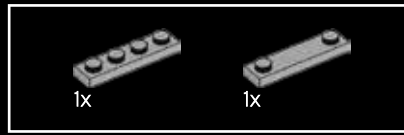
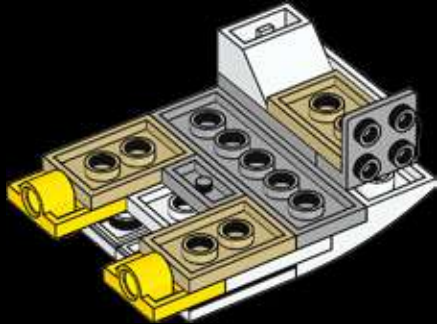

206

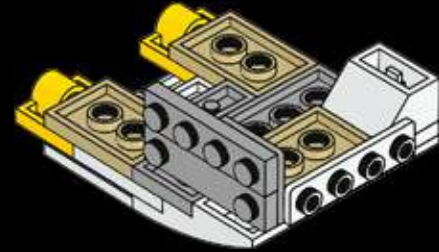

207

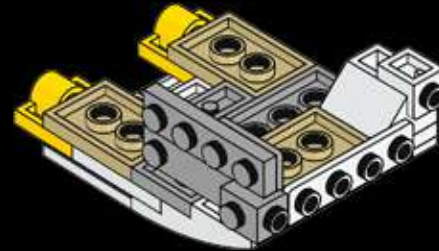



208

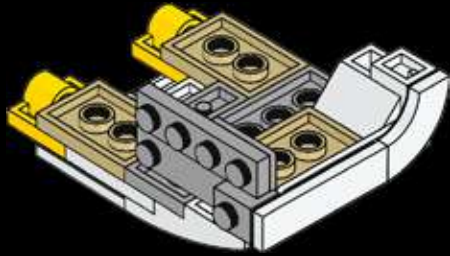

209

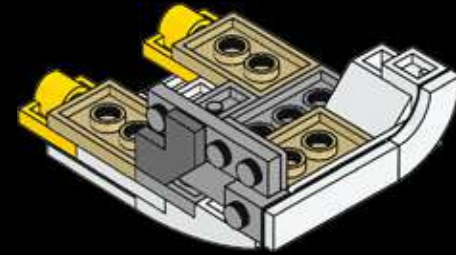

210

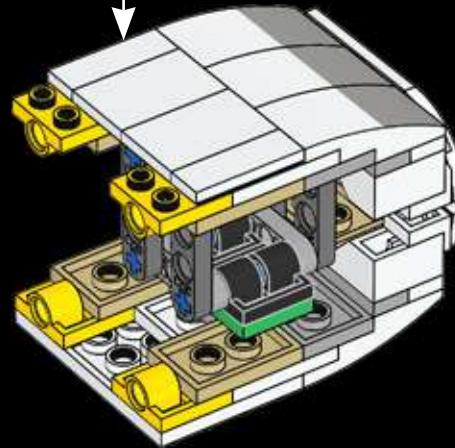

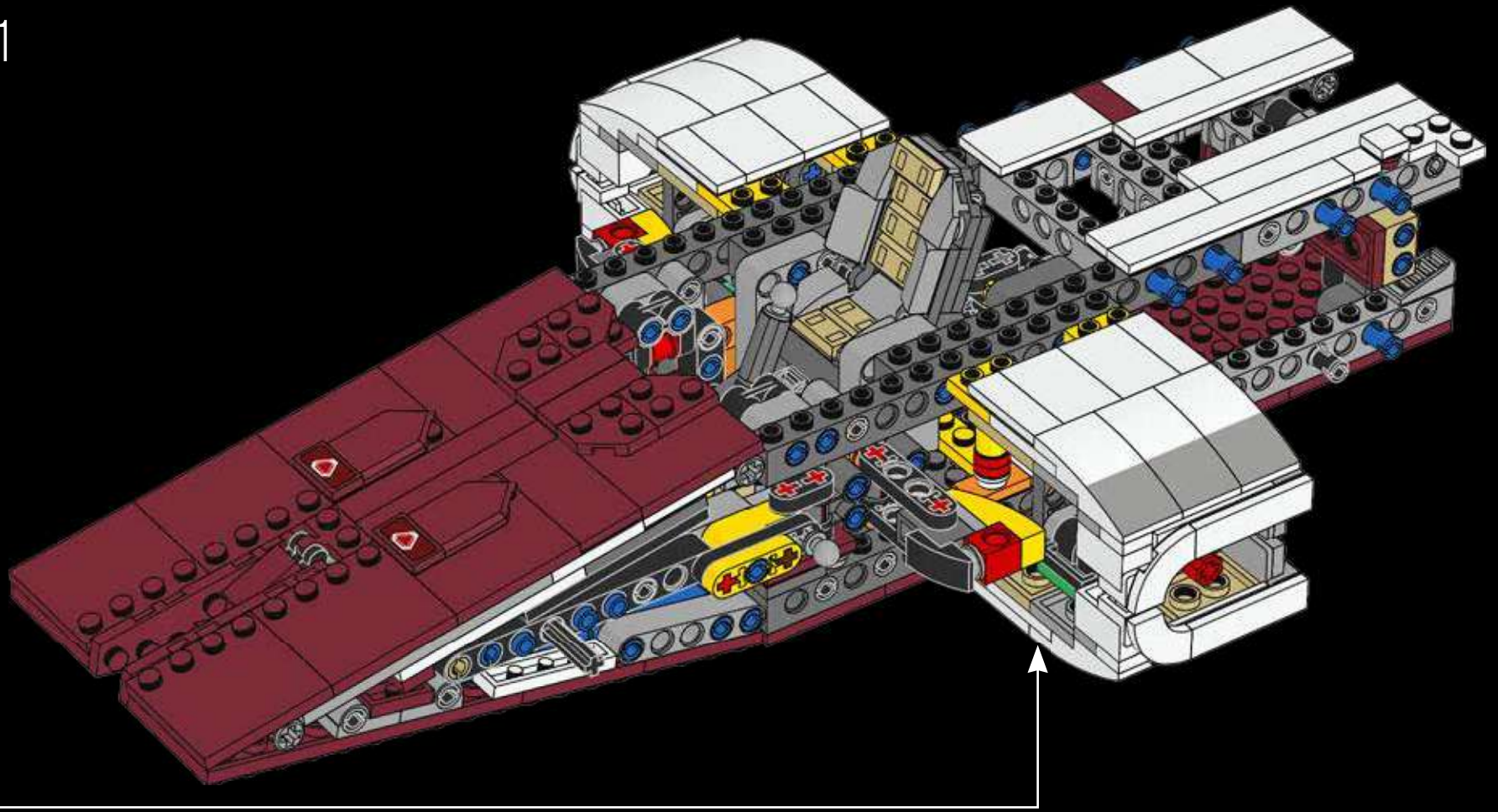



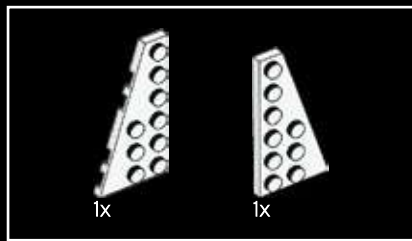

212

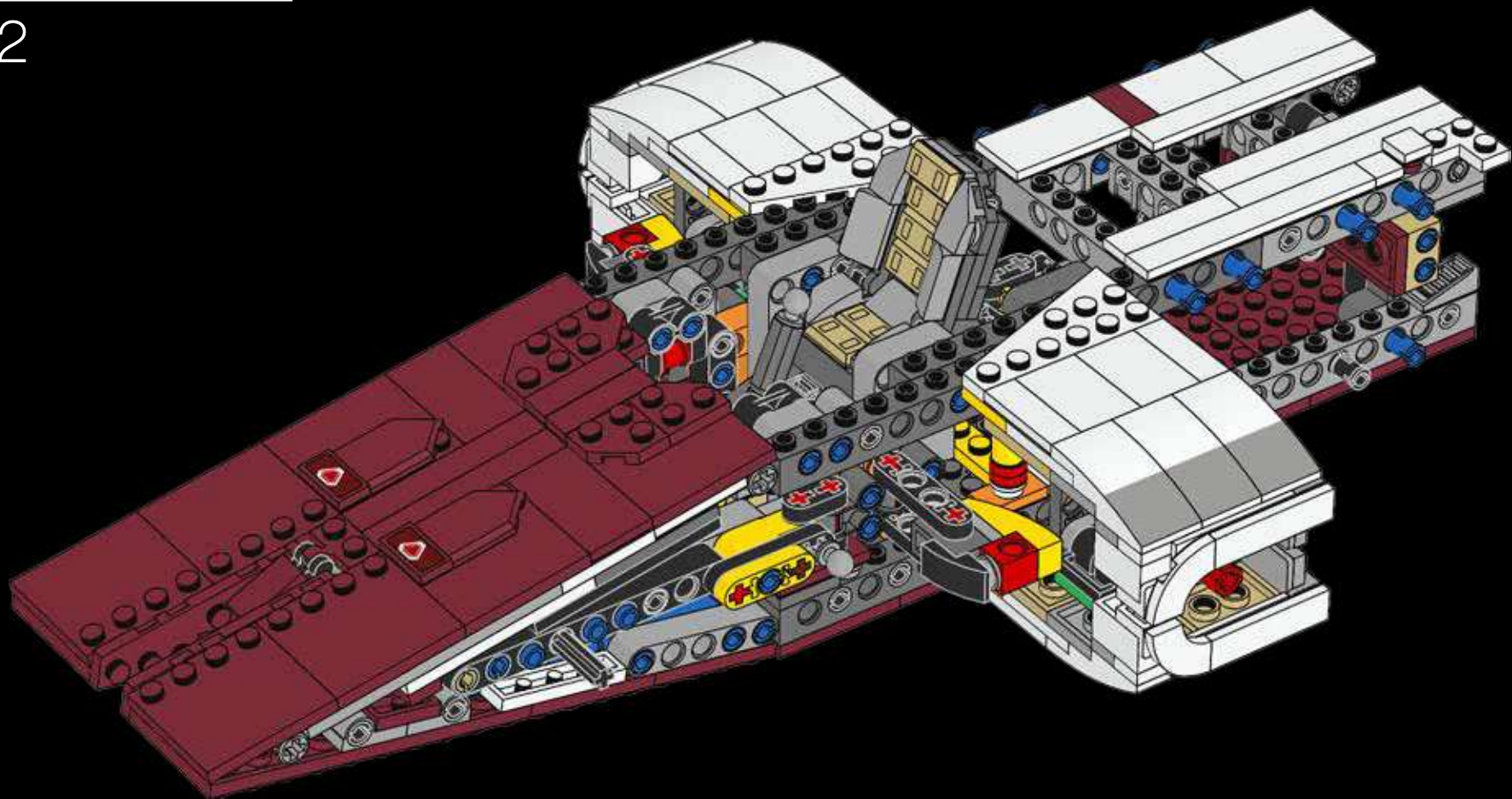

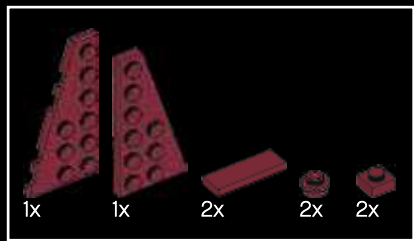

213

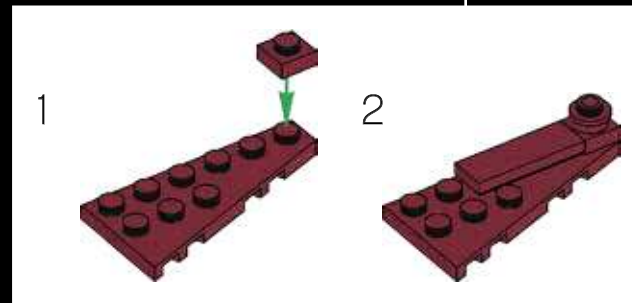
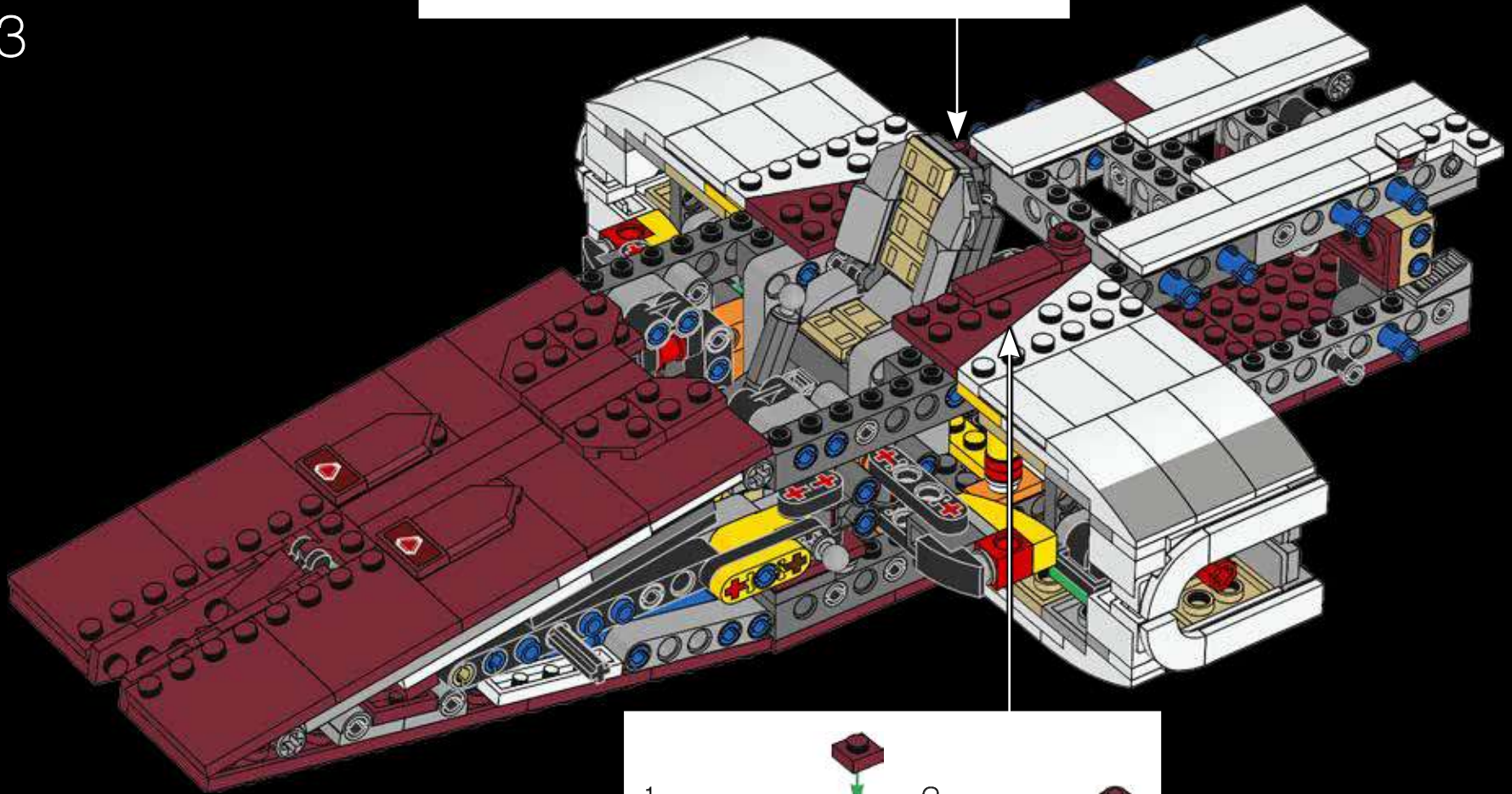
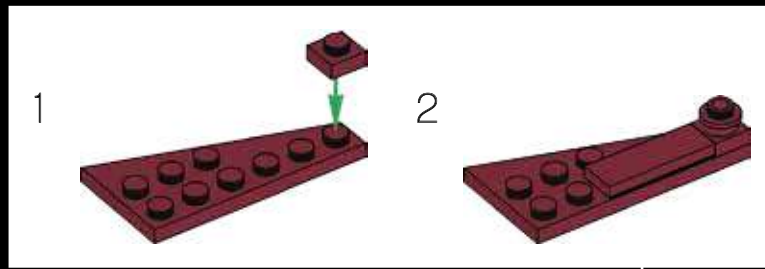

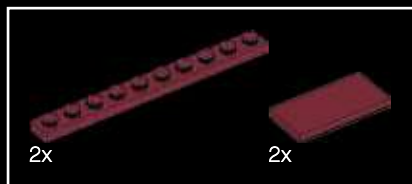

214

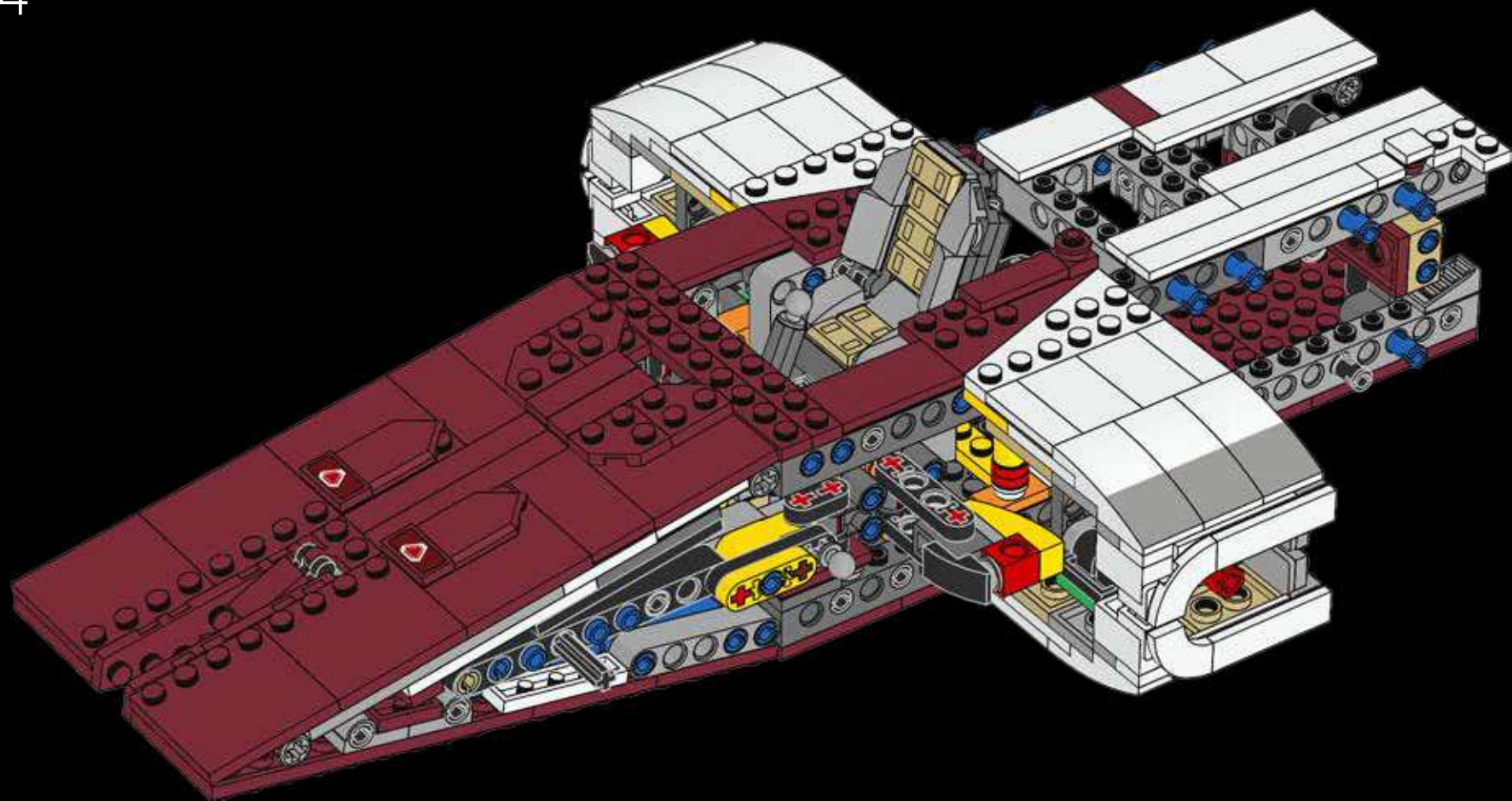

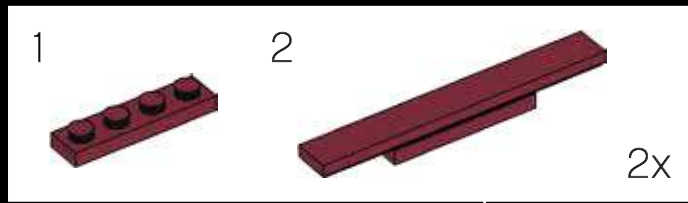
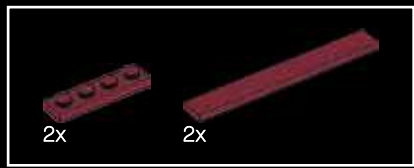

215

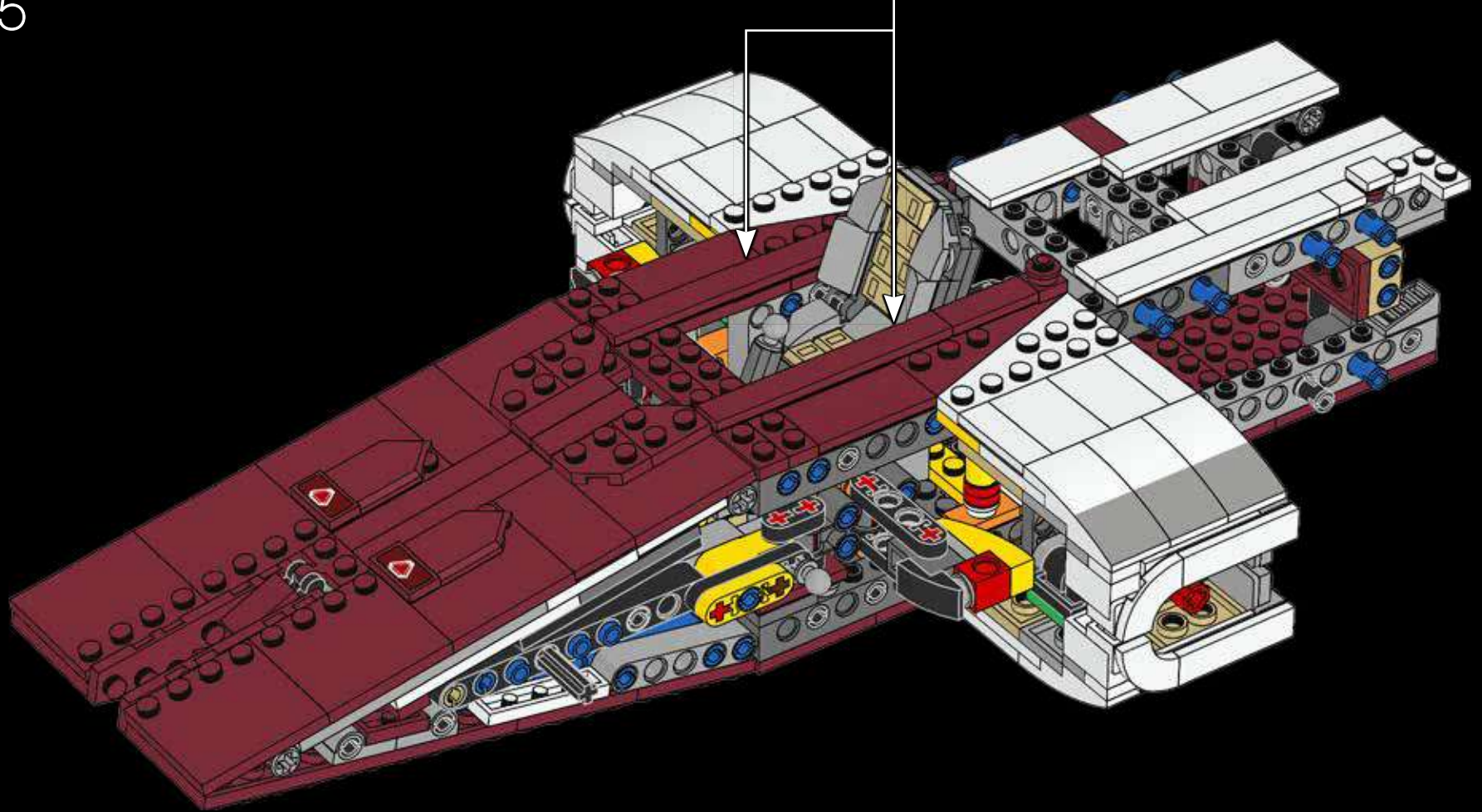

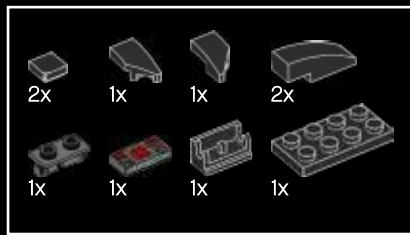

216

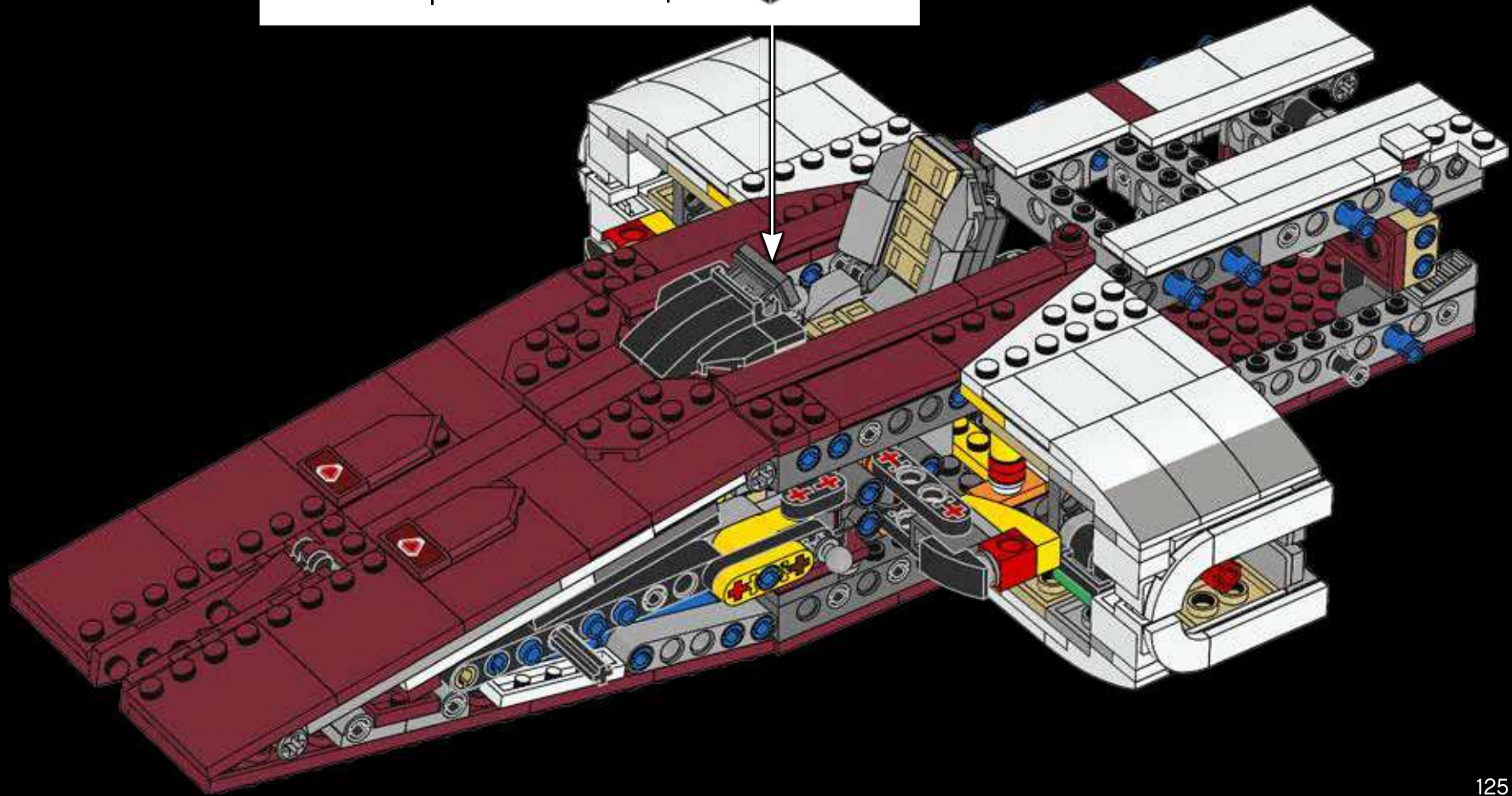
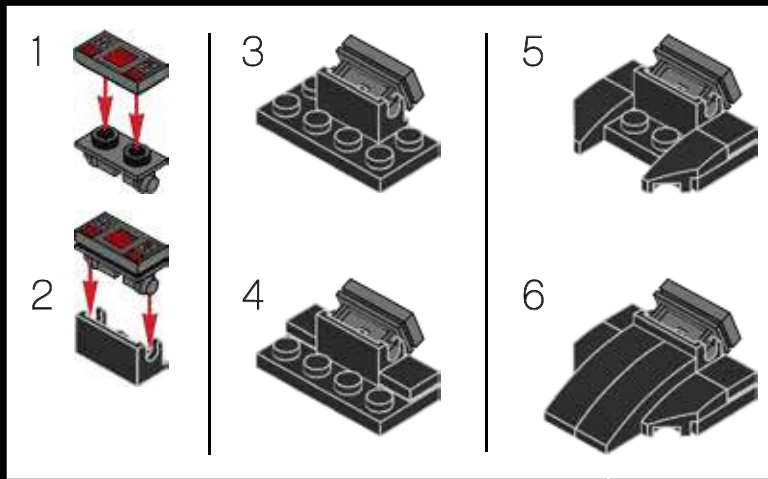

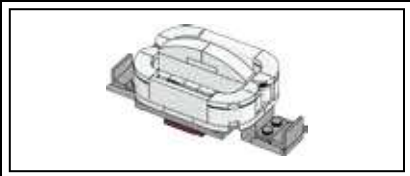
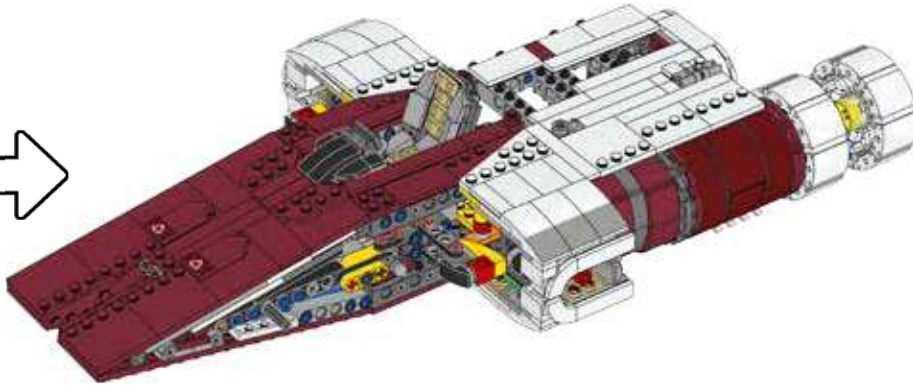
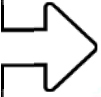

217

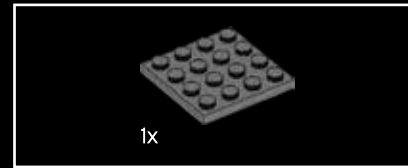

218



219



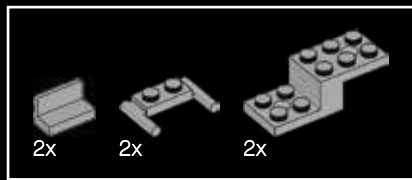

220

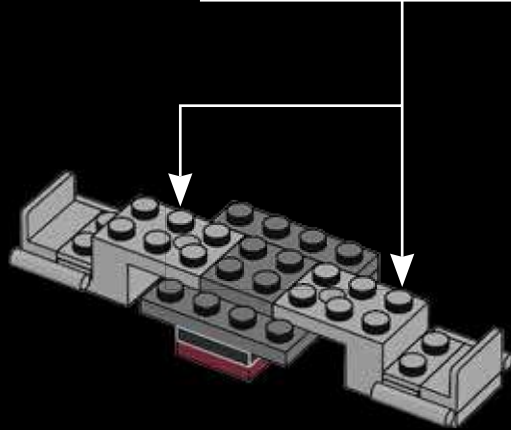
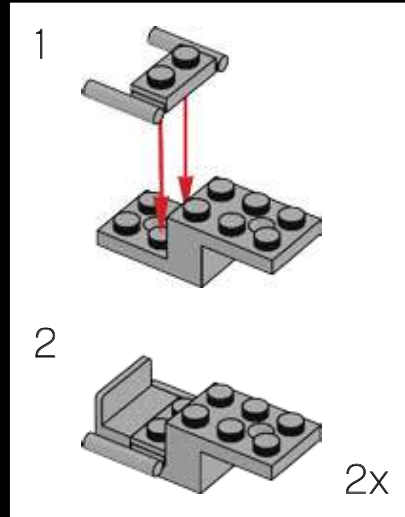

221

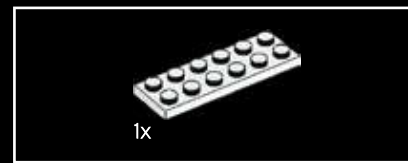
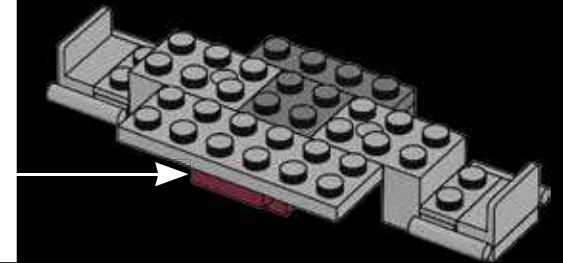
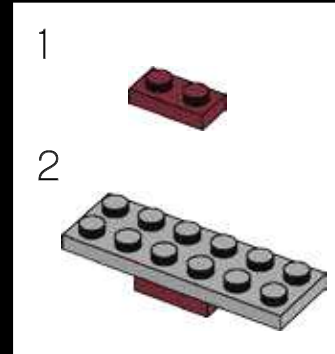

222

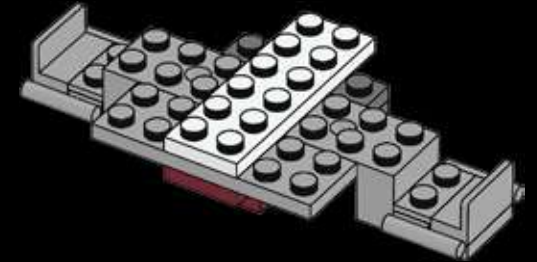



223

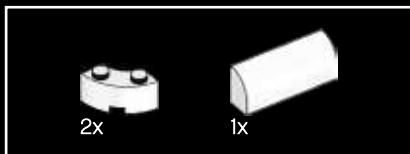
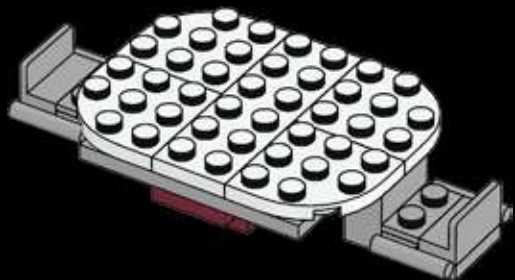

224

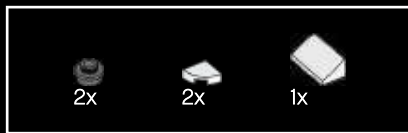

225

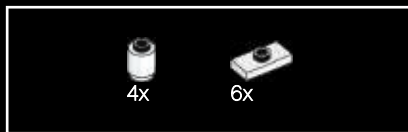
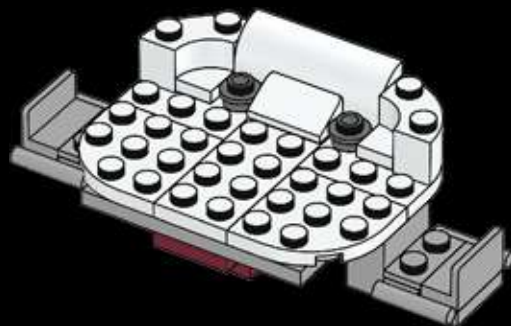

226

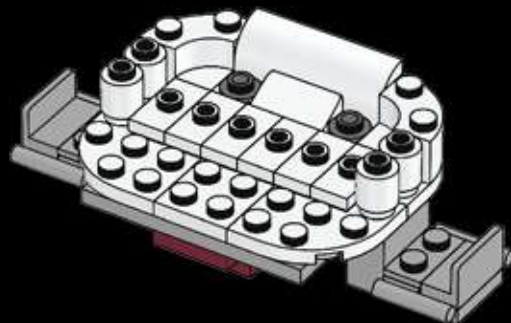



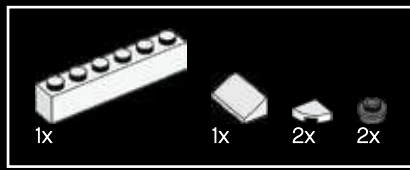

227

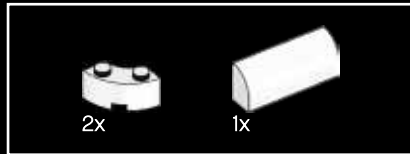
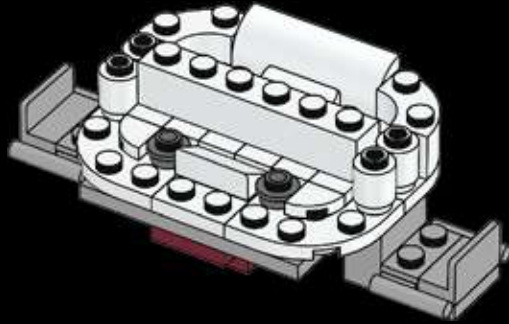

228

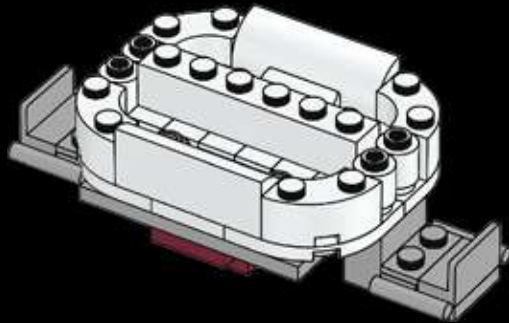

229

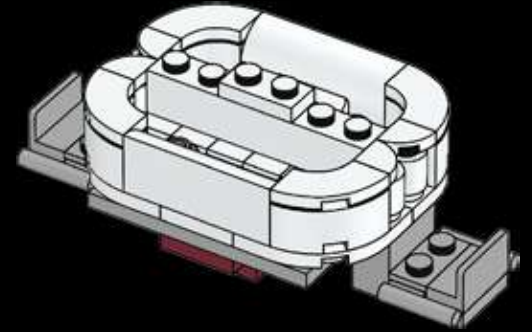

230

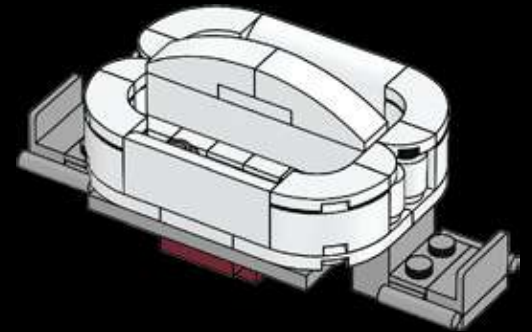

231

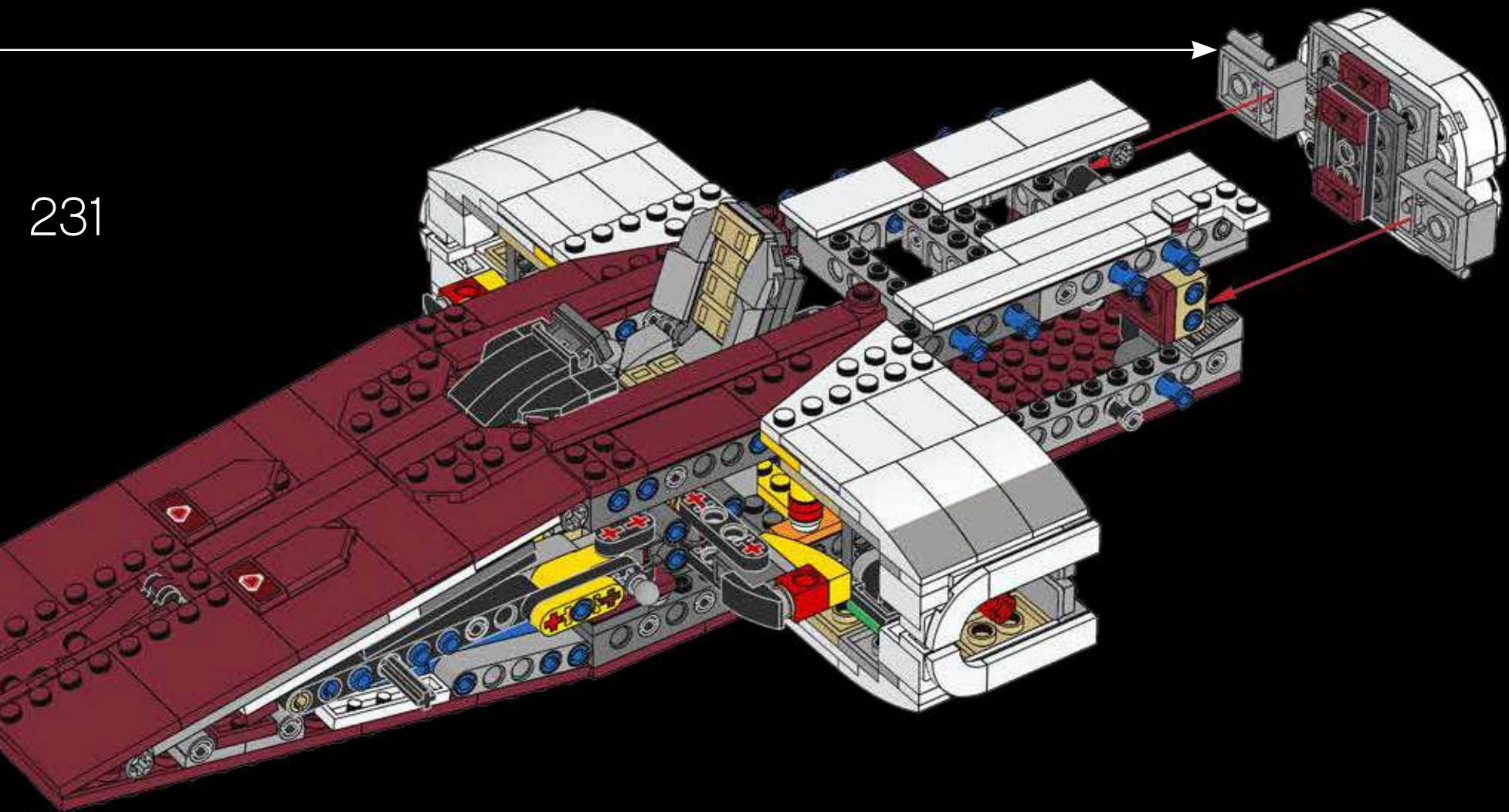

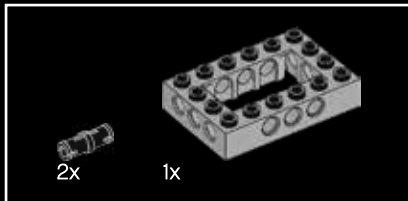
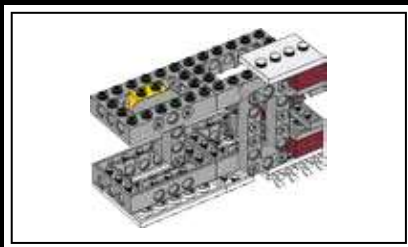

232



233

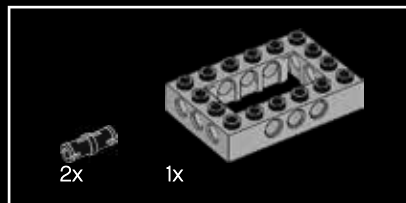
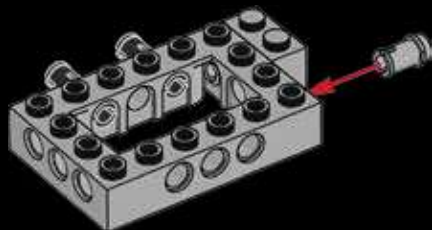

234

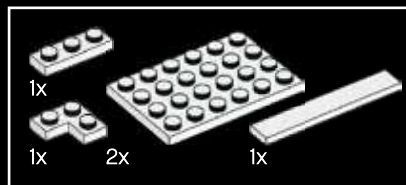
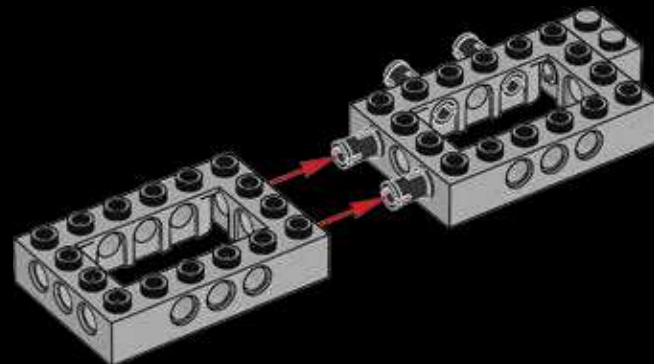

235

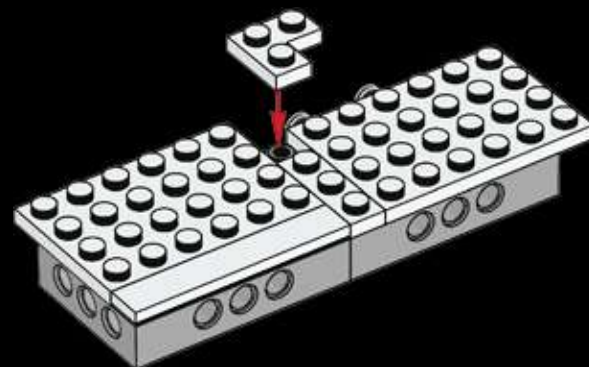

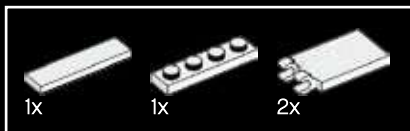

236

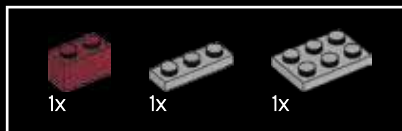
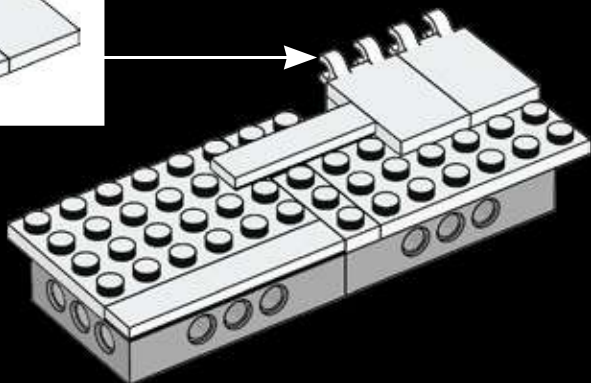
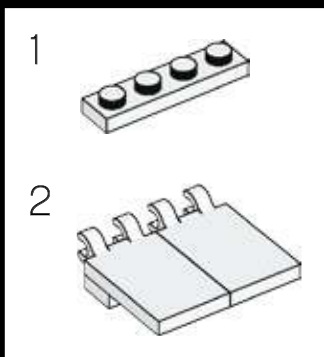

237

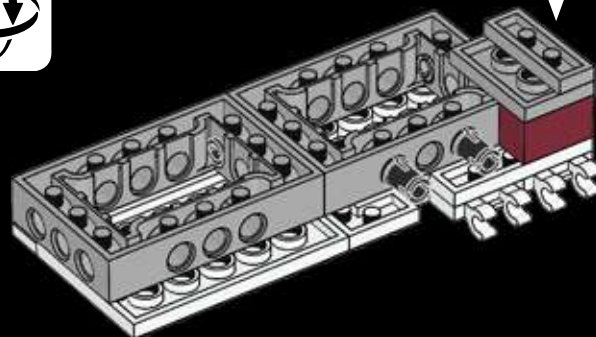
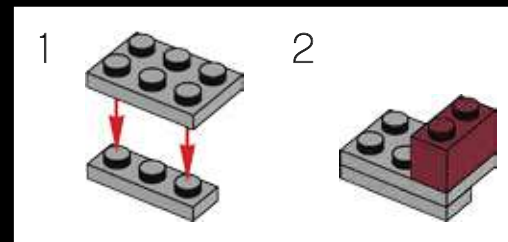

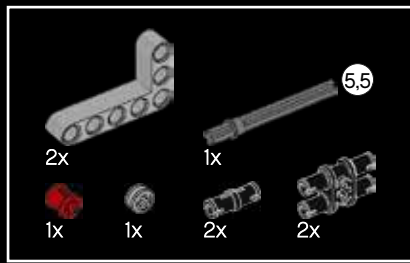

238

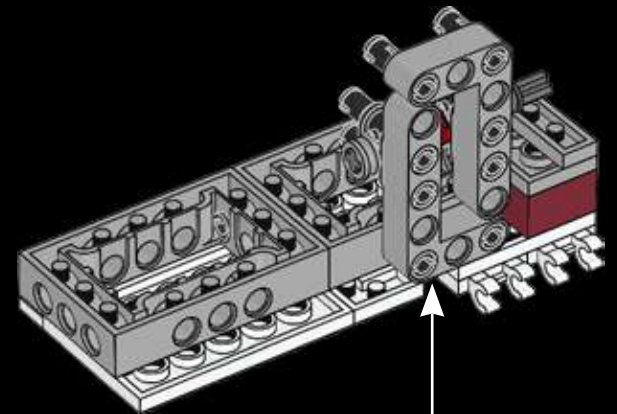
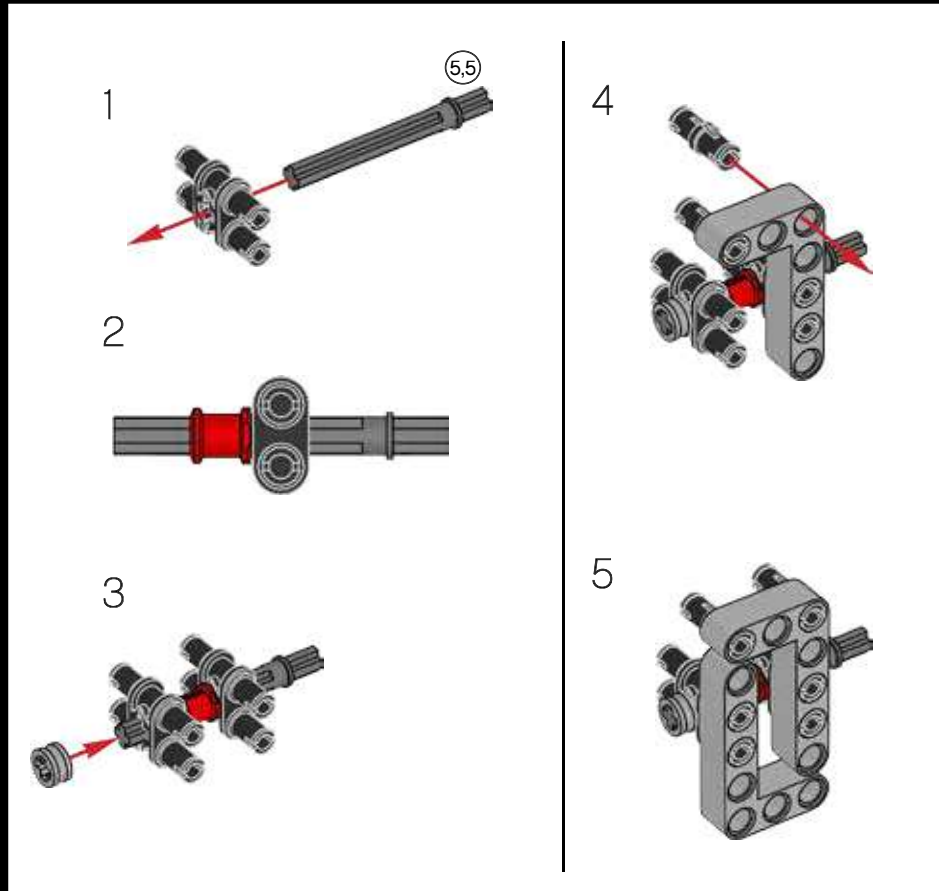

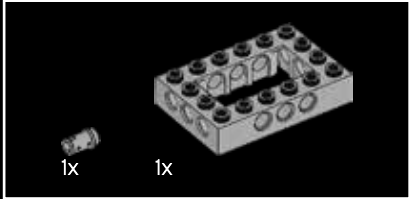
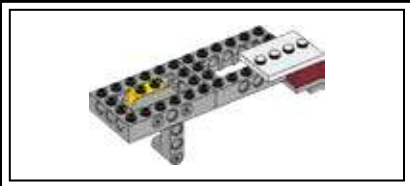

239

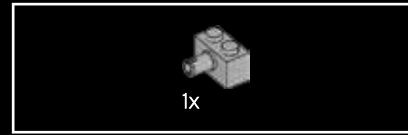
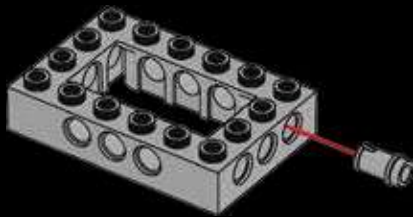

240

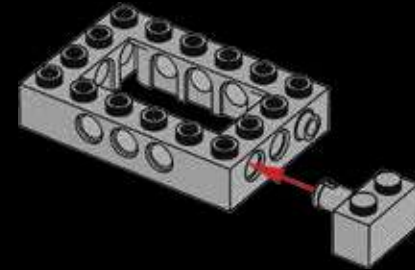

241

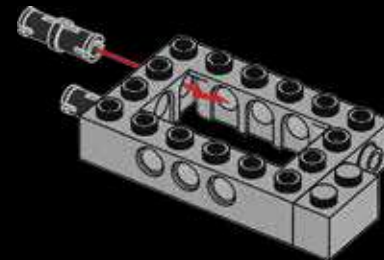



242

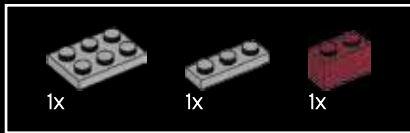
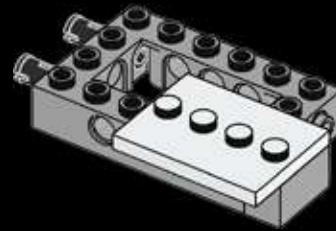

243

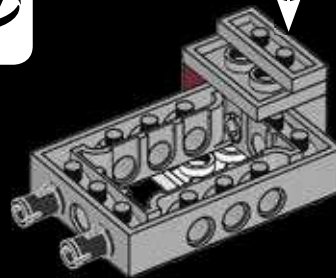
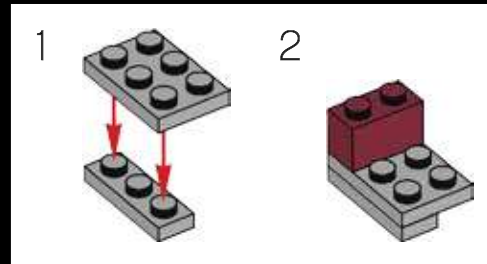

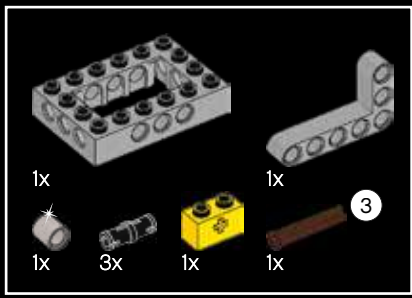

244

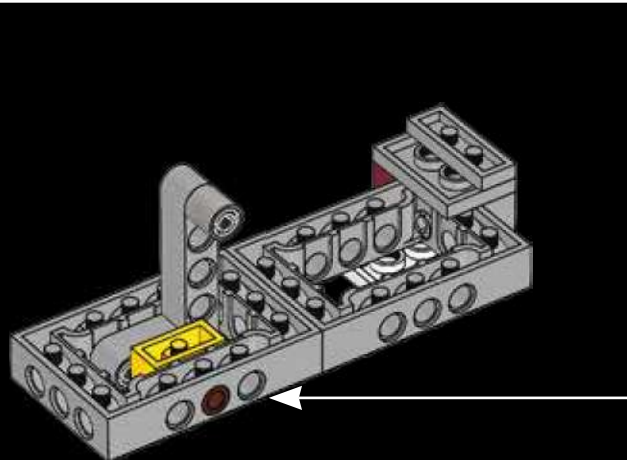
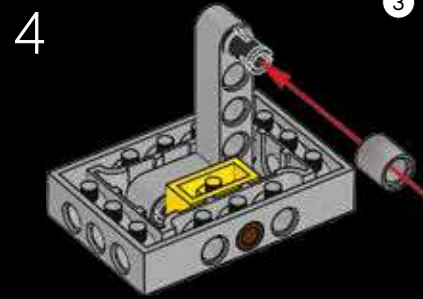
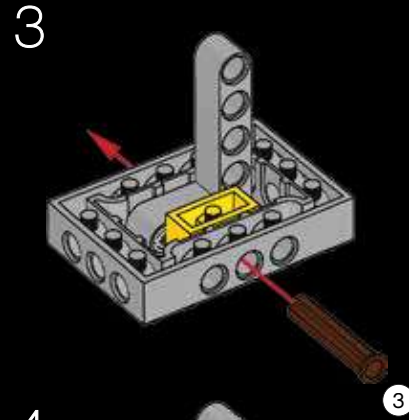
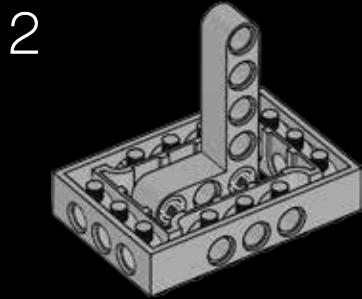
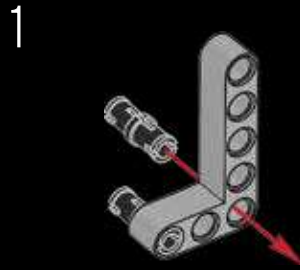



245

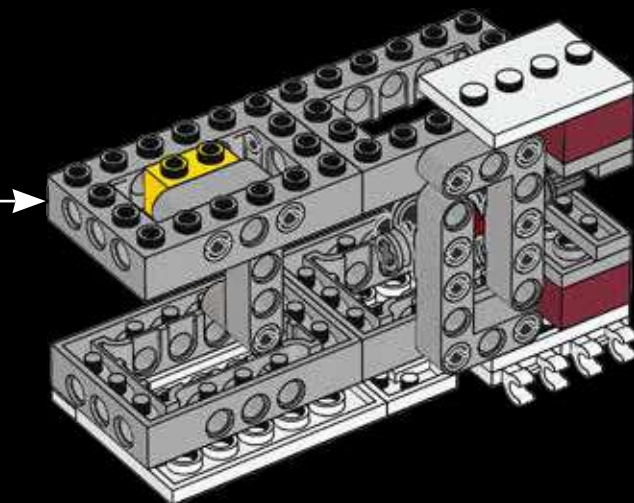

246

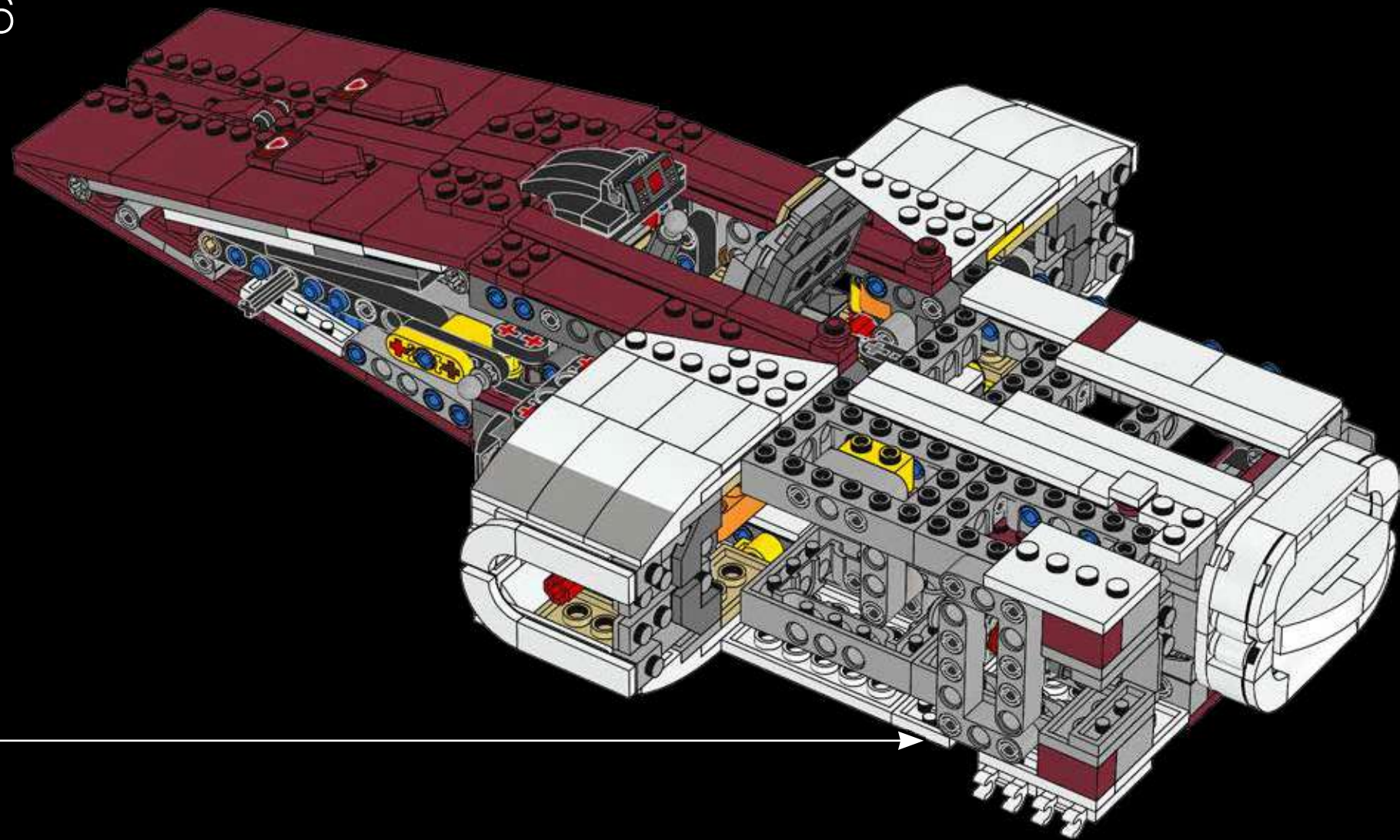

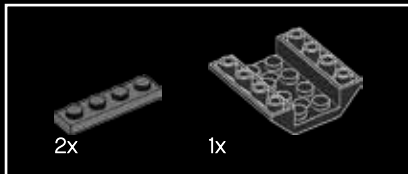

247

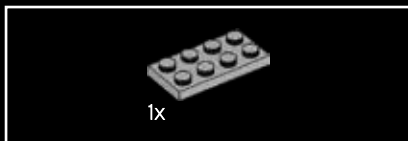
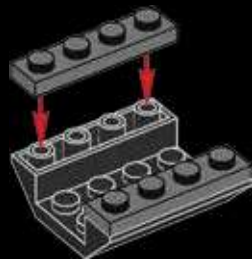

248

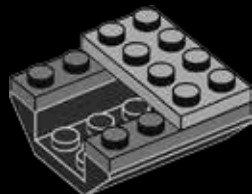

4x

249

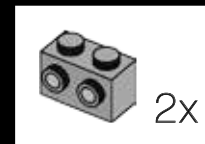

2x

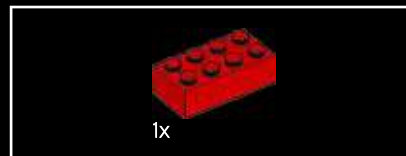
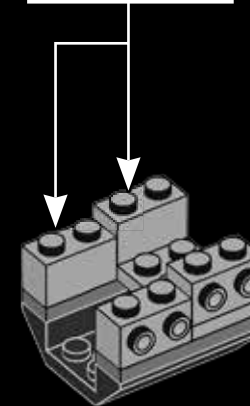

1x

250

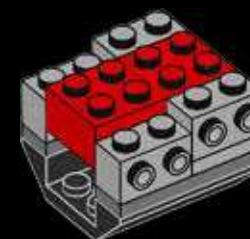

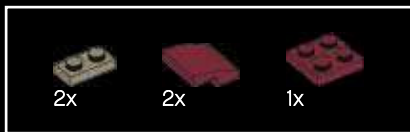

251

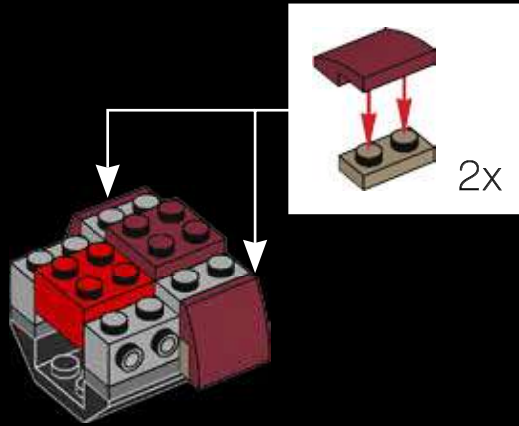

252

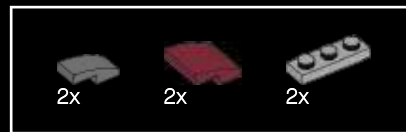
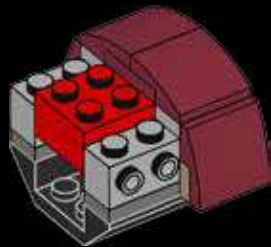

253

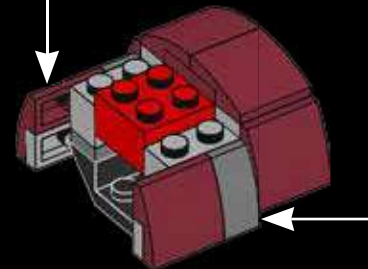
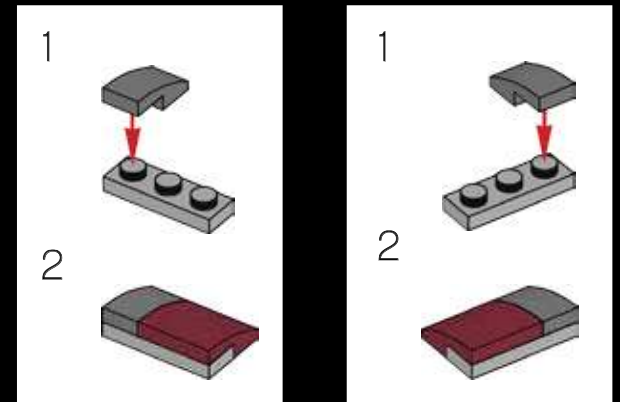



254



255

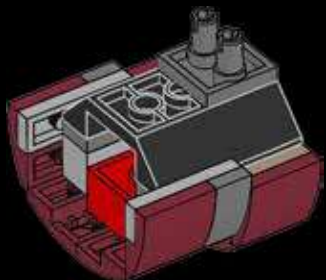

256

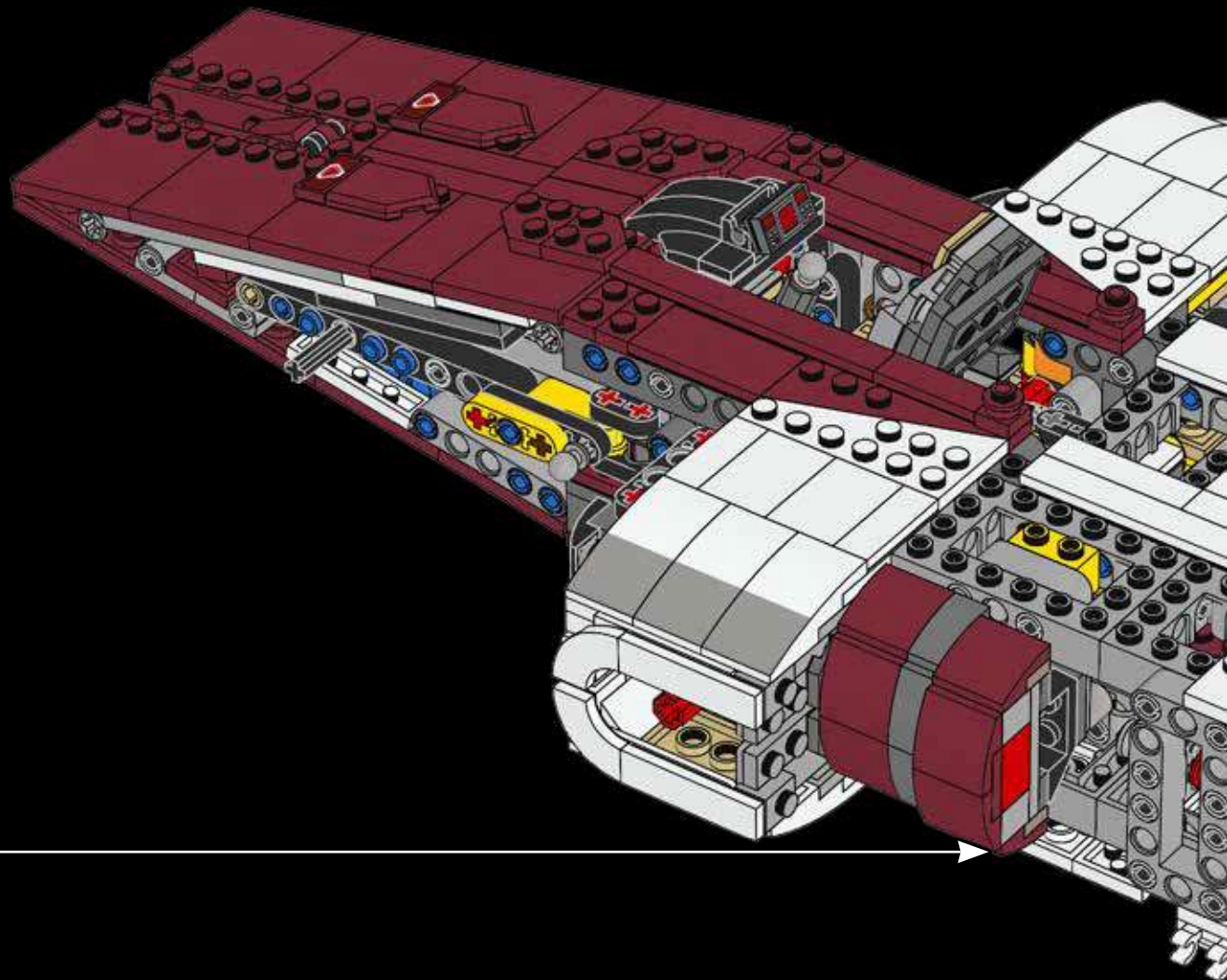

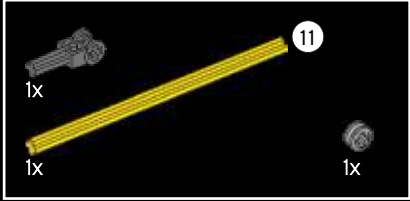
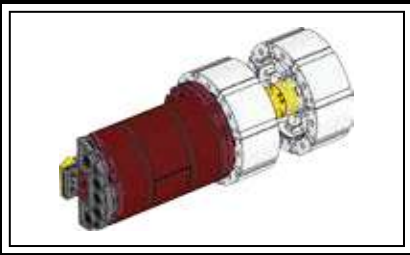

257

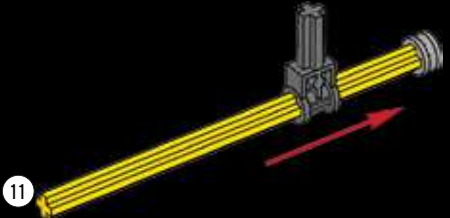

258



142

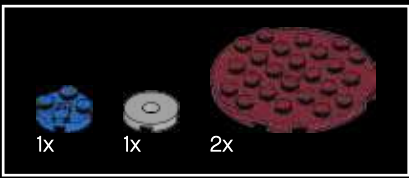

259

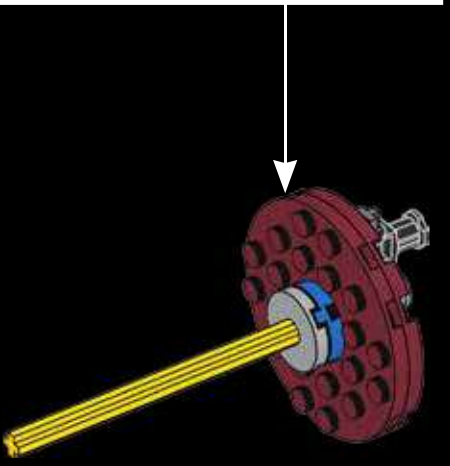
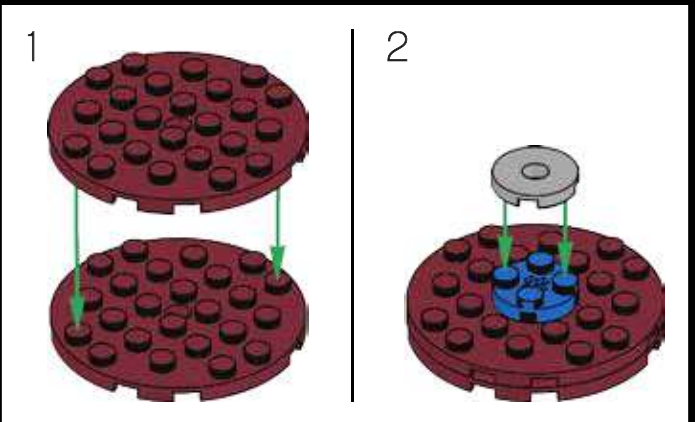

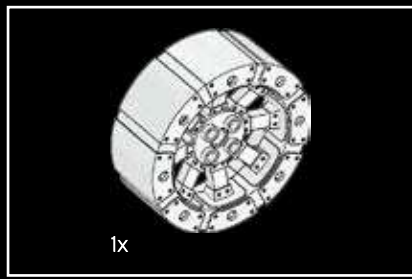

260

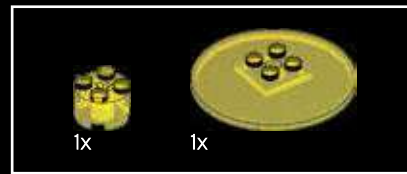
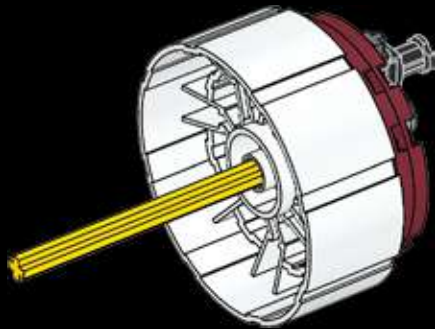

261

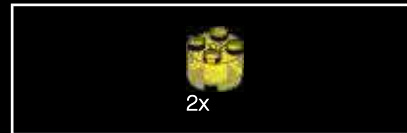
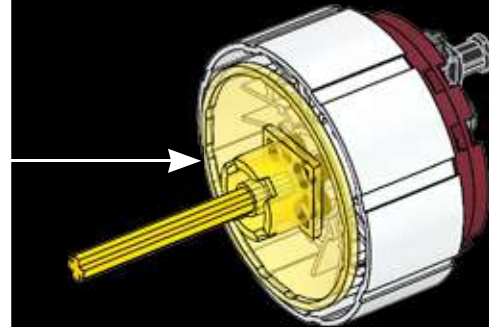
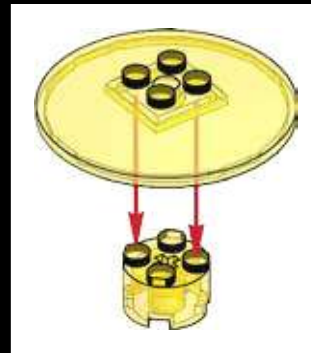

262

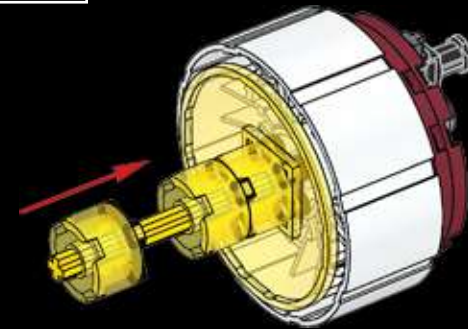

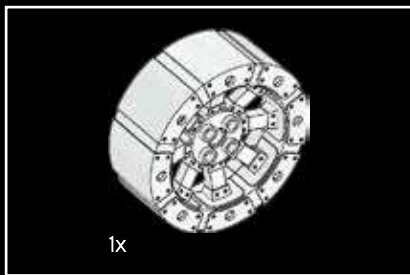

263

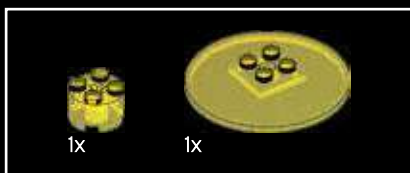
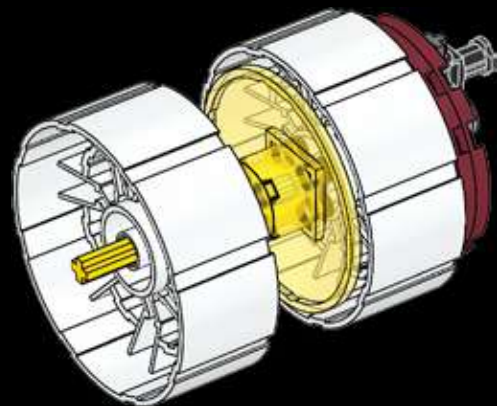

264

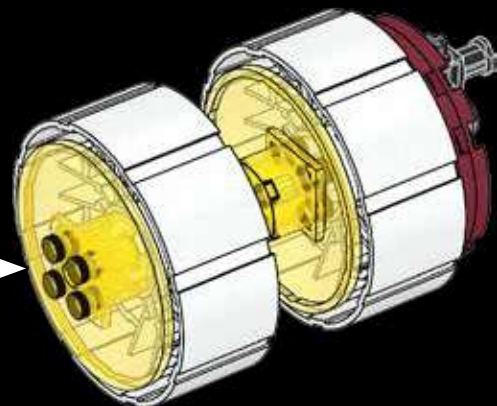
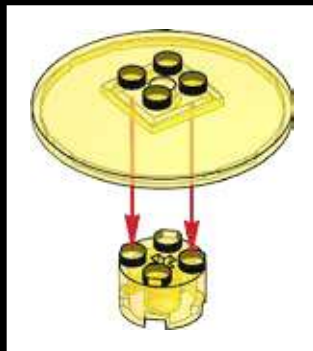





265



266



267

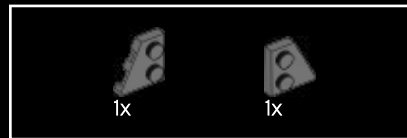

268

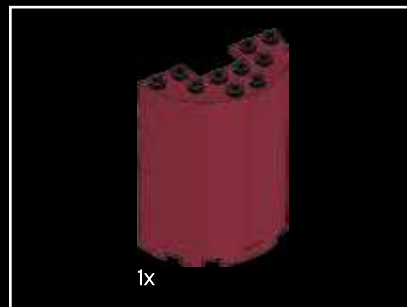

269



270

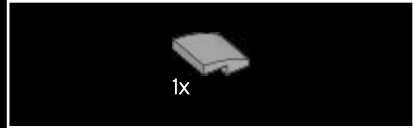
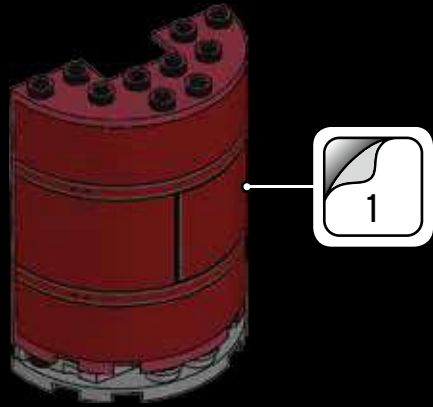

271



272

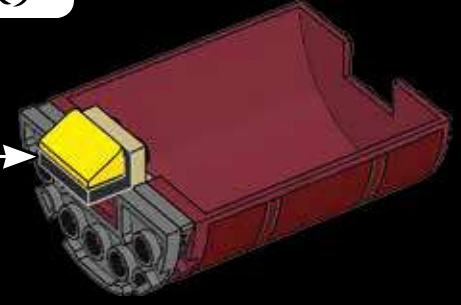
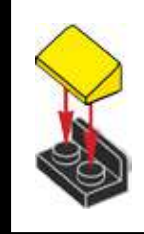

273

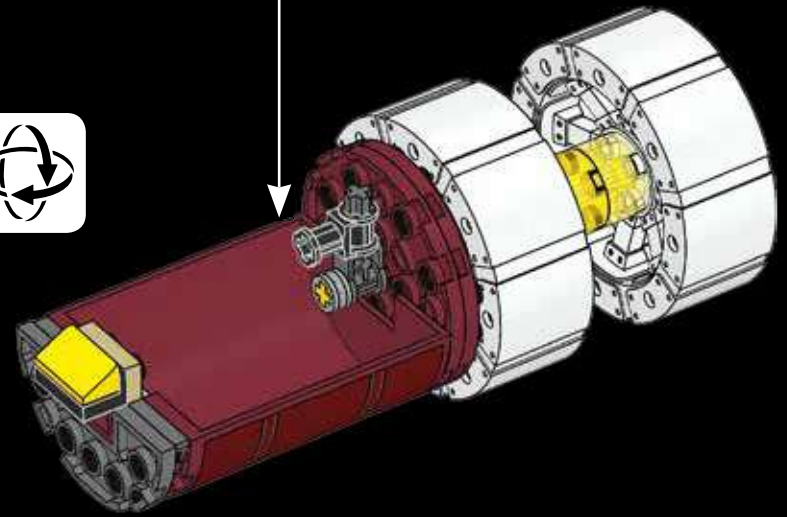

274

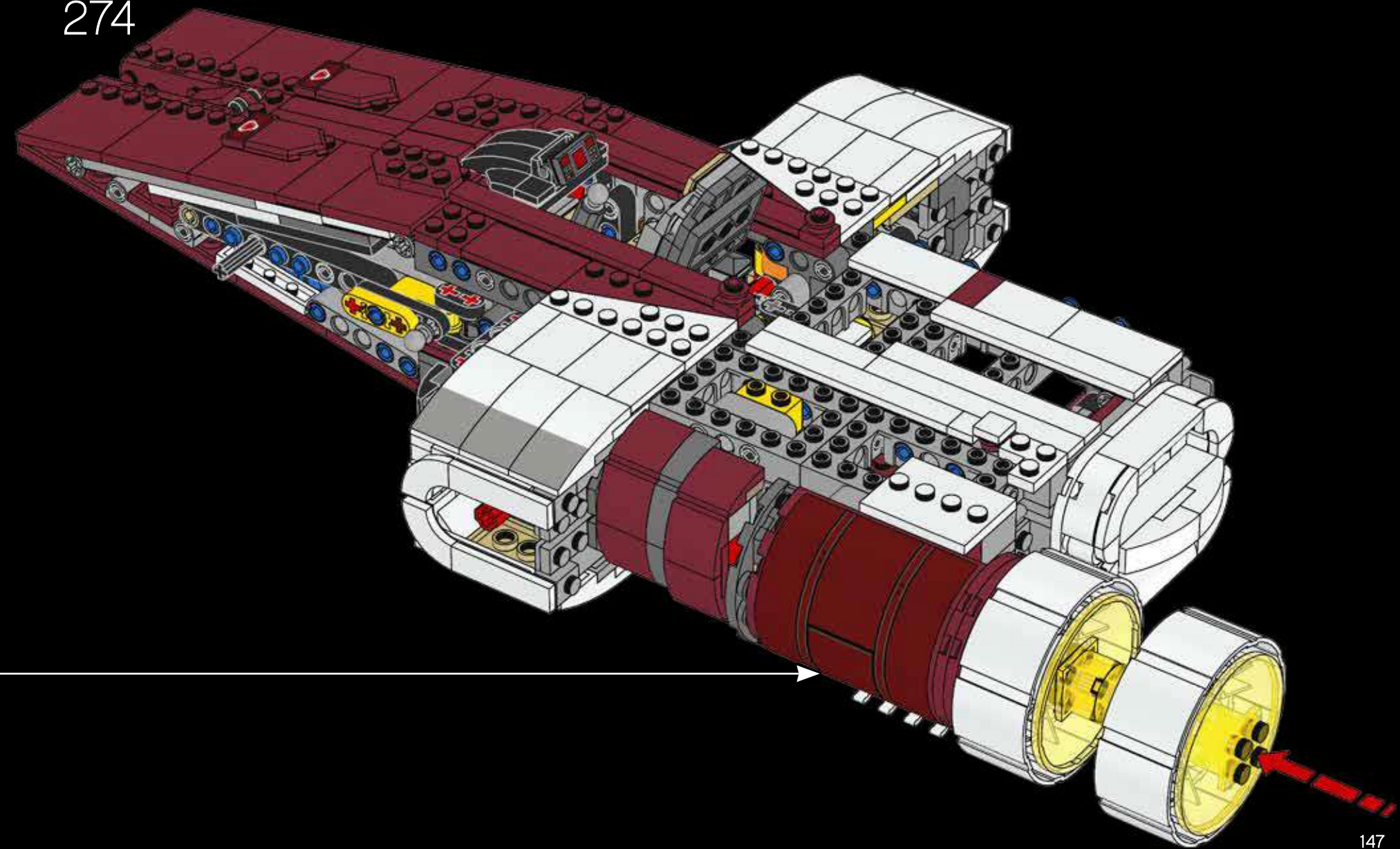

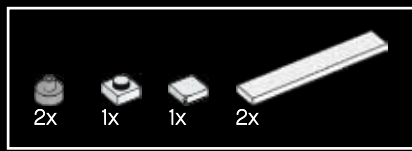

275

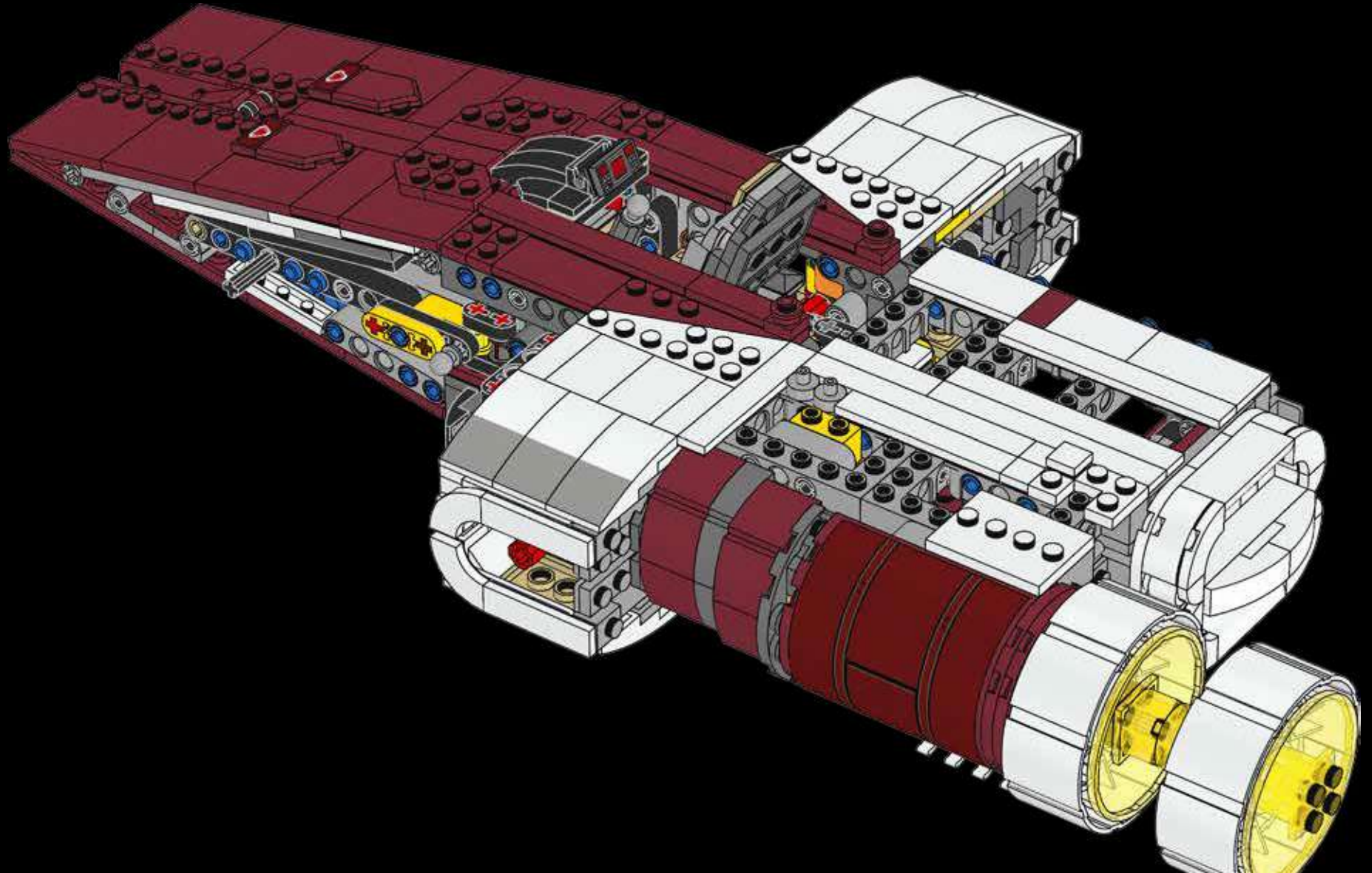

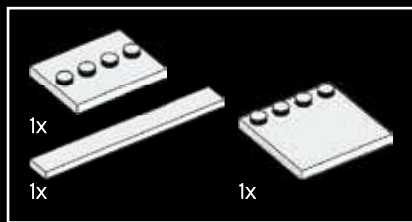

276

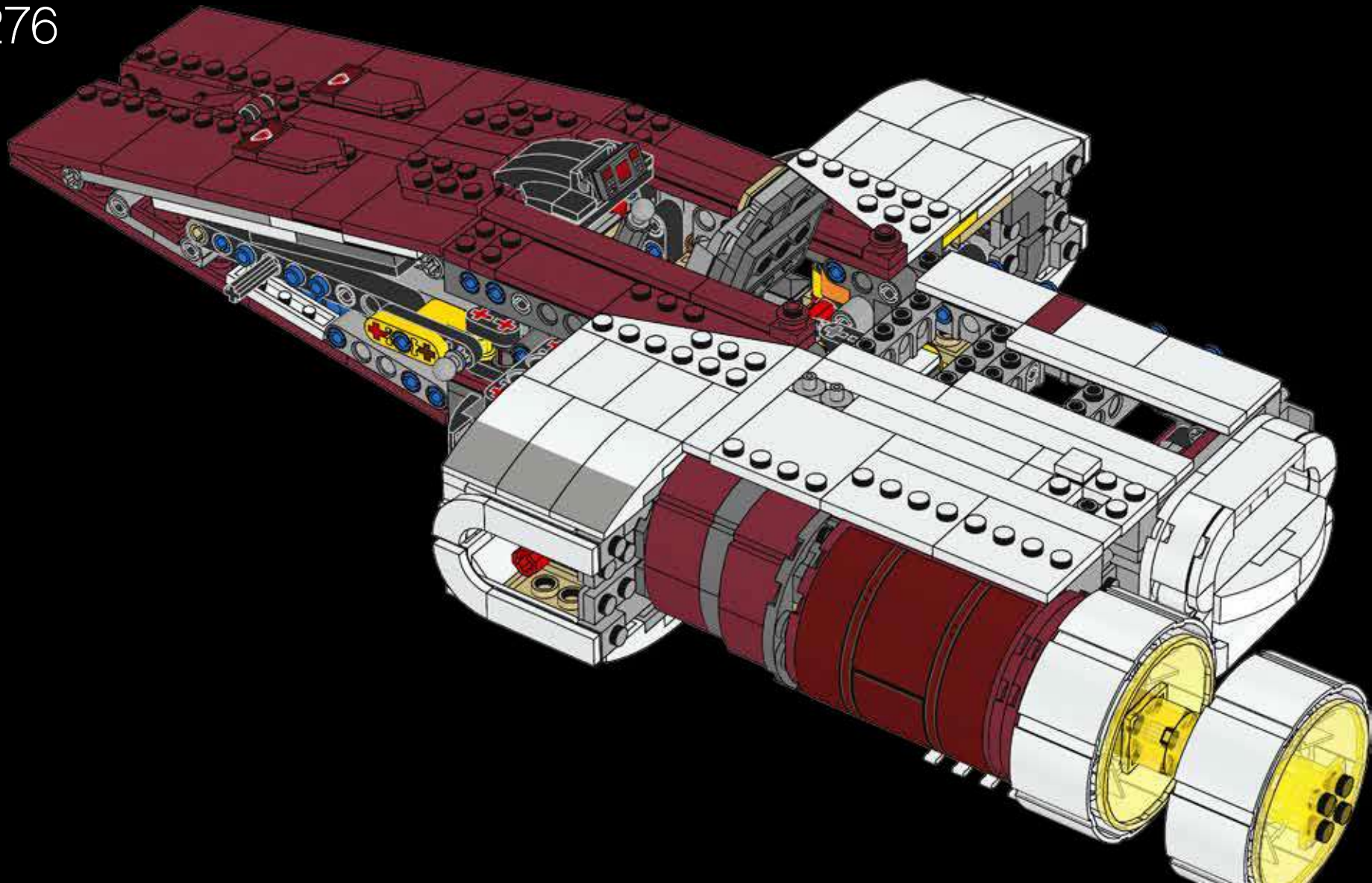



277

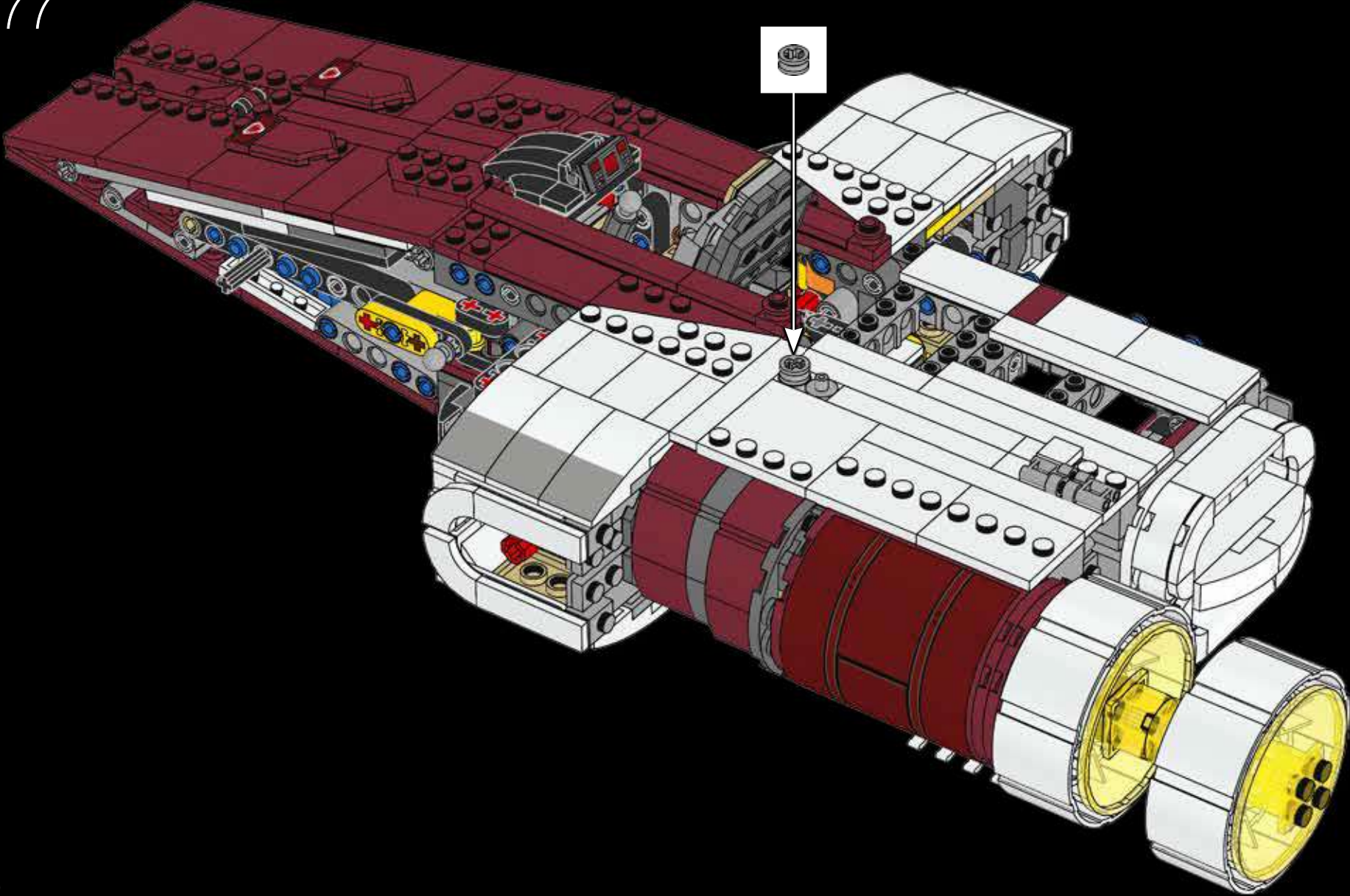

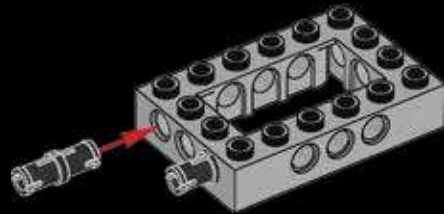
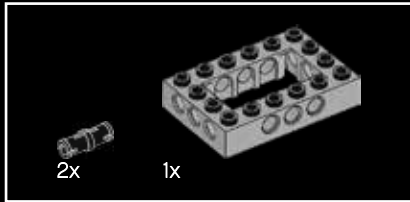
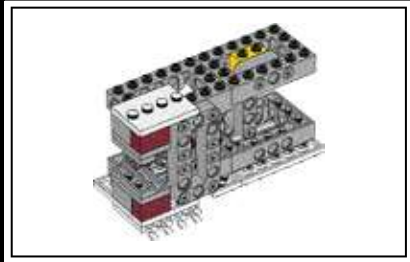
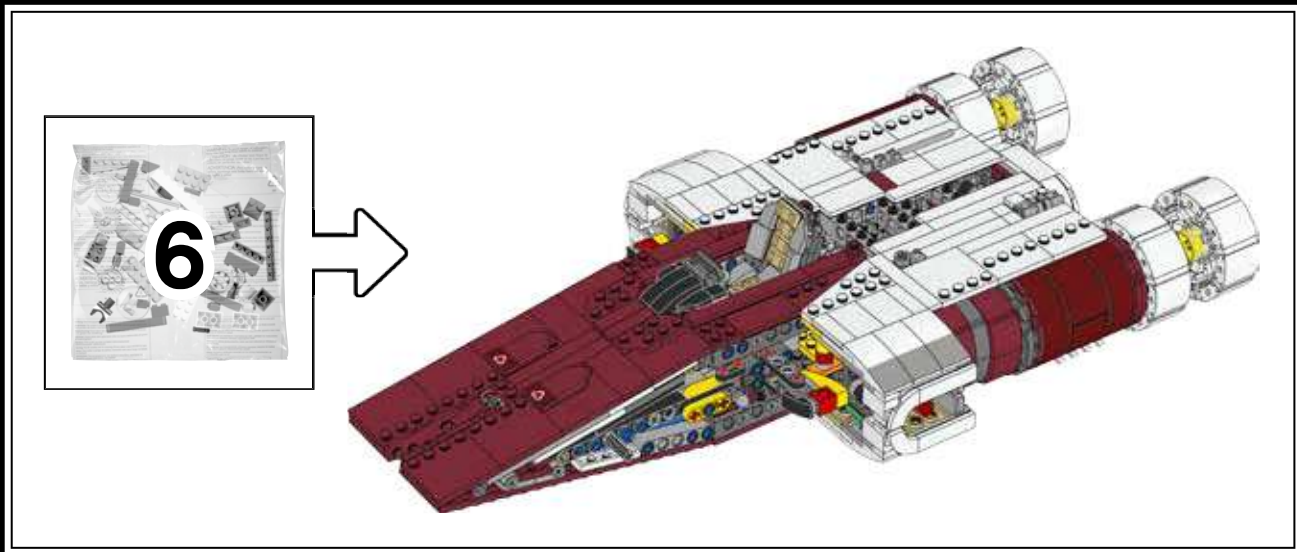

278

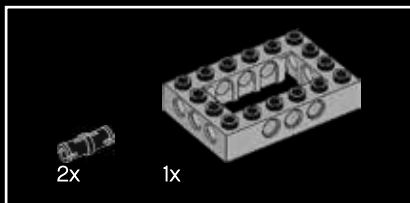

279

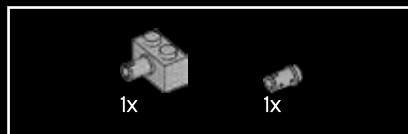
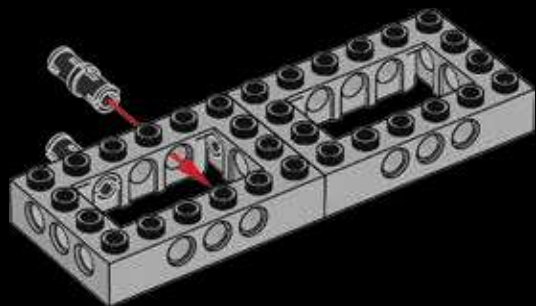

280

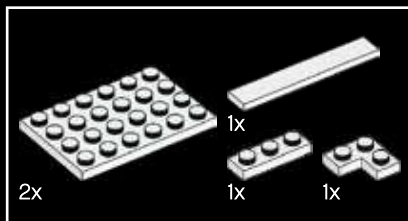
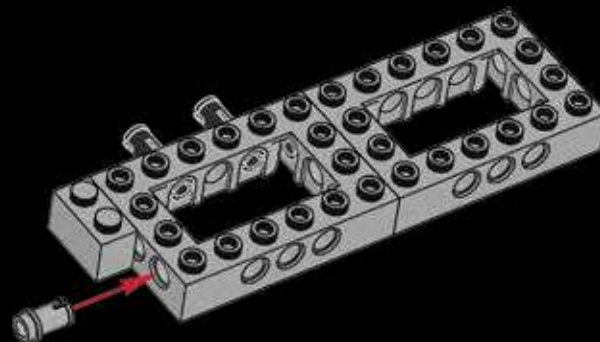

281

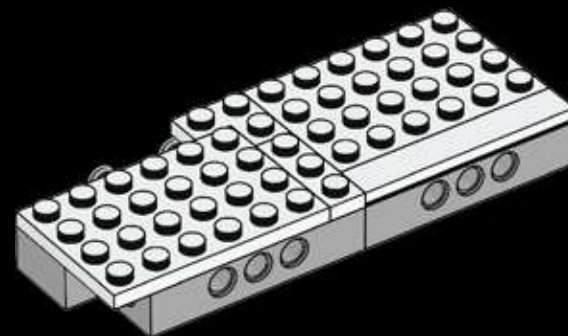



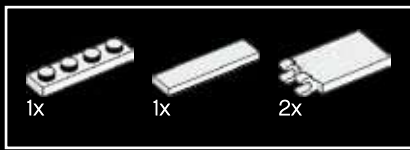

282

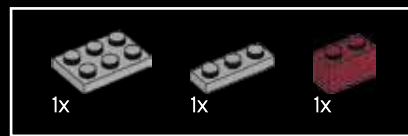
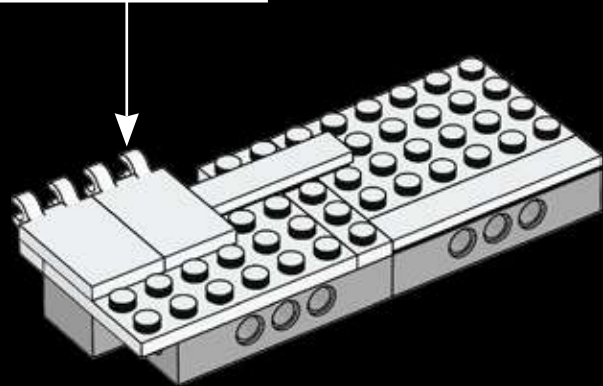
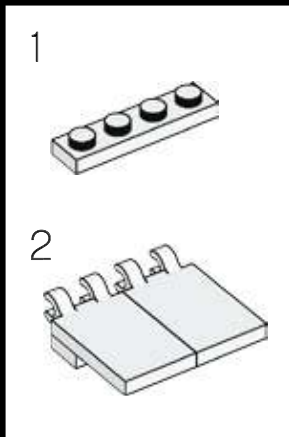

283

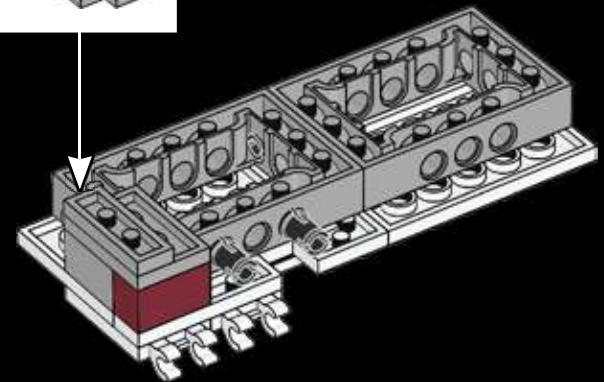
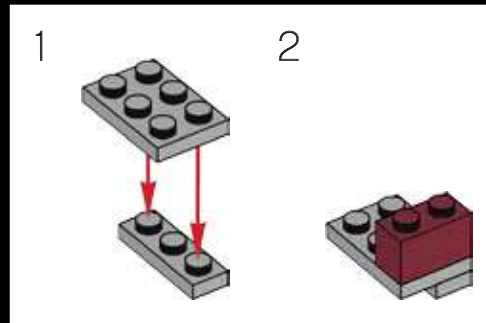

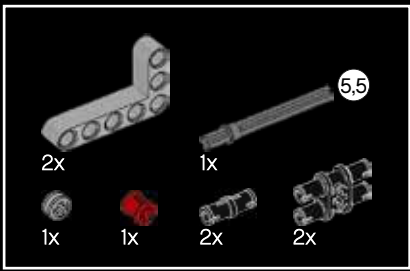

284

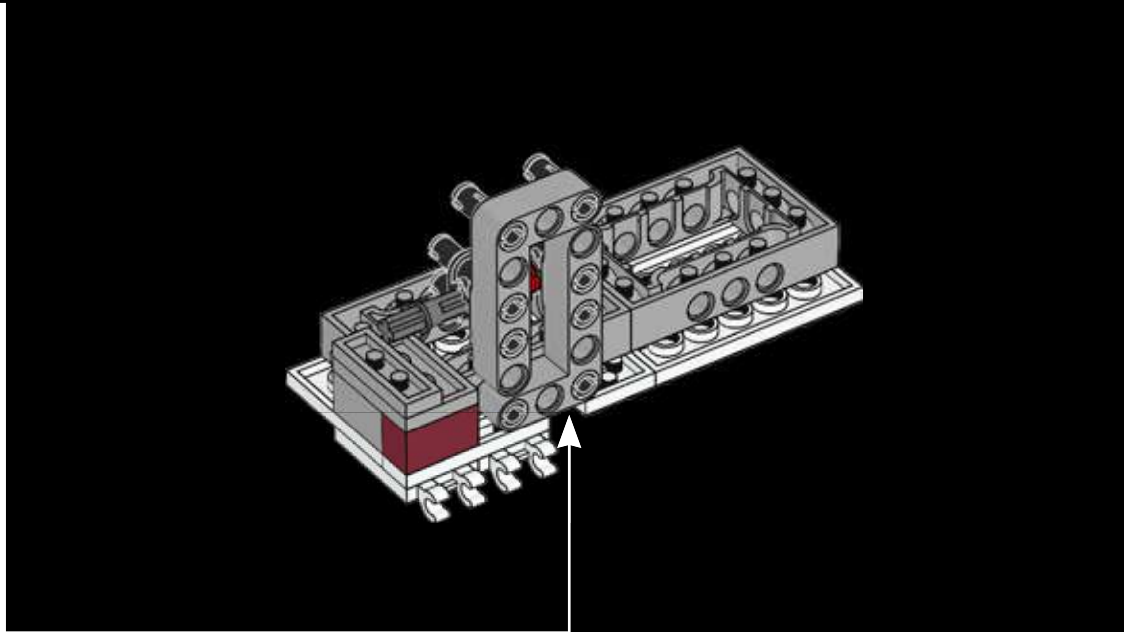
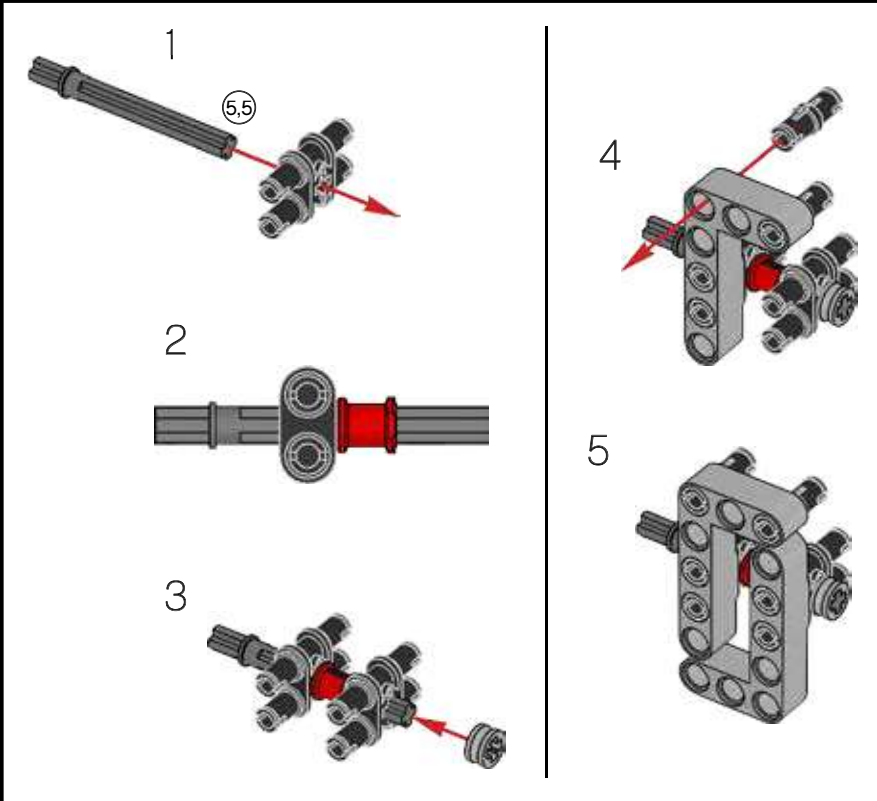

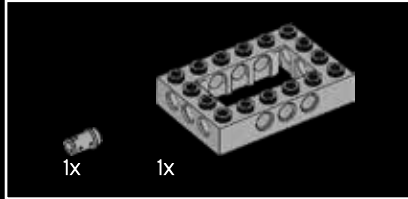
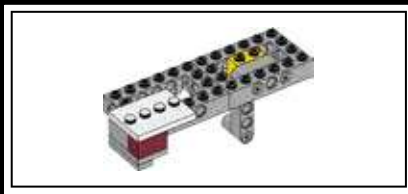

285

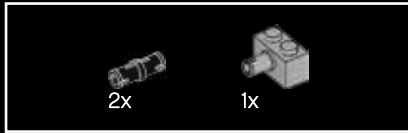
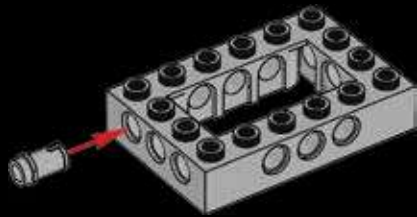

286

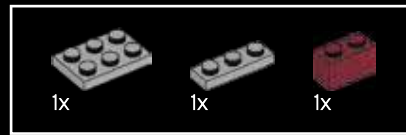
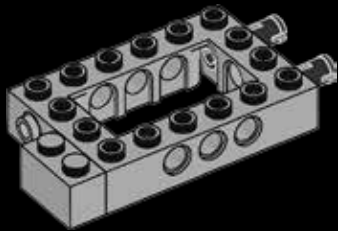

287

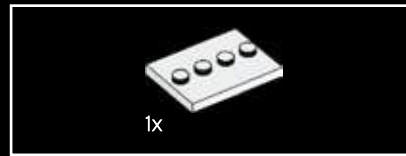
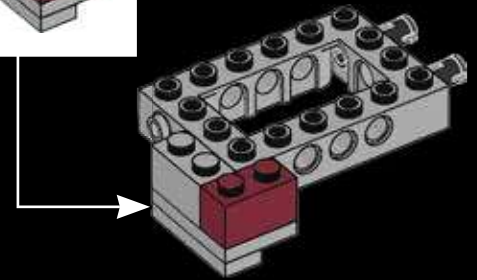
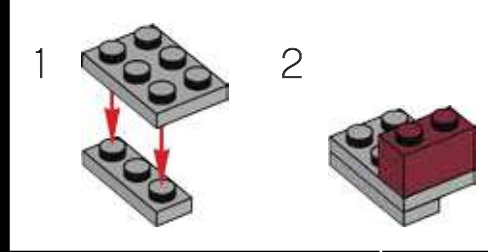

288

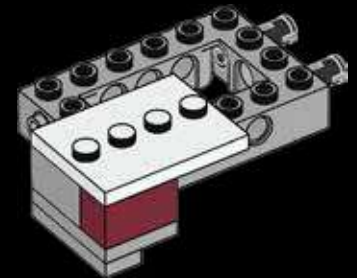

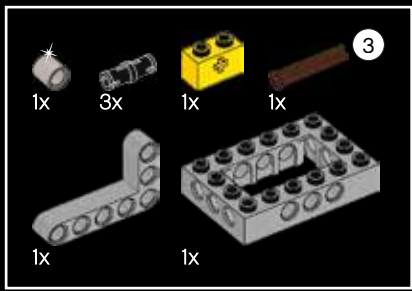

289

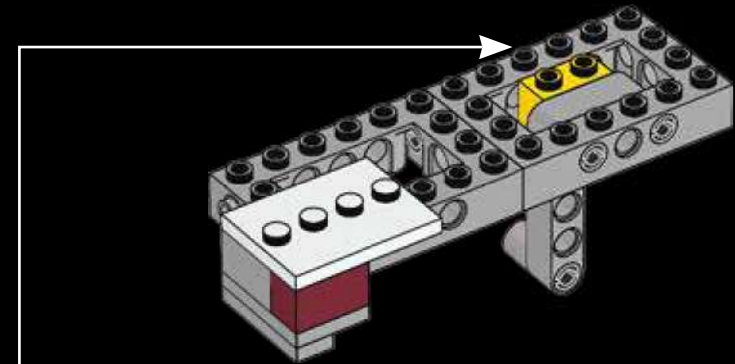
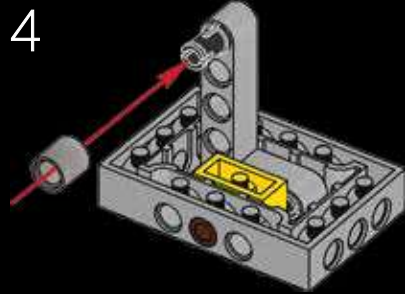
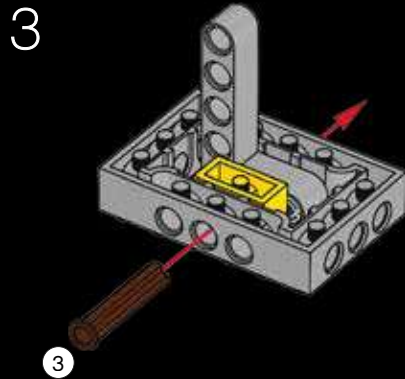
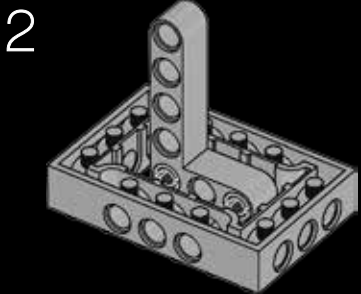
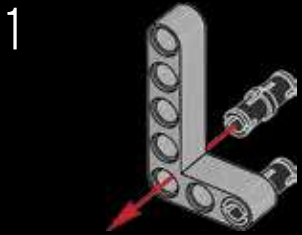

290

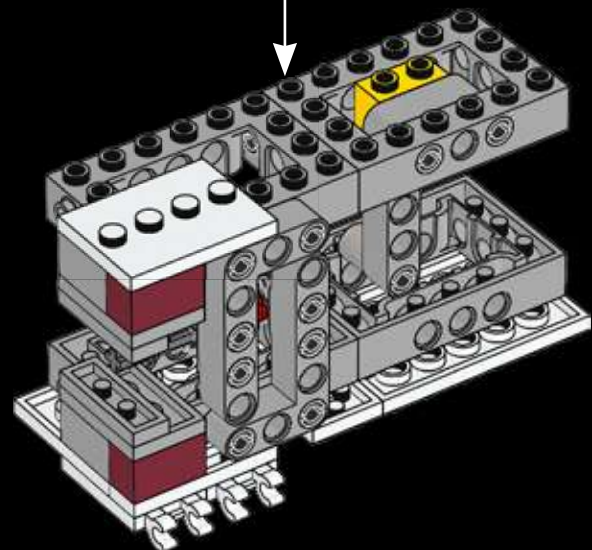

291

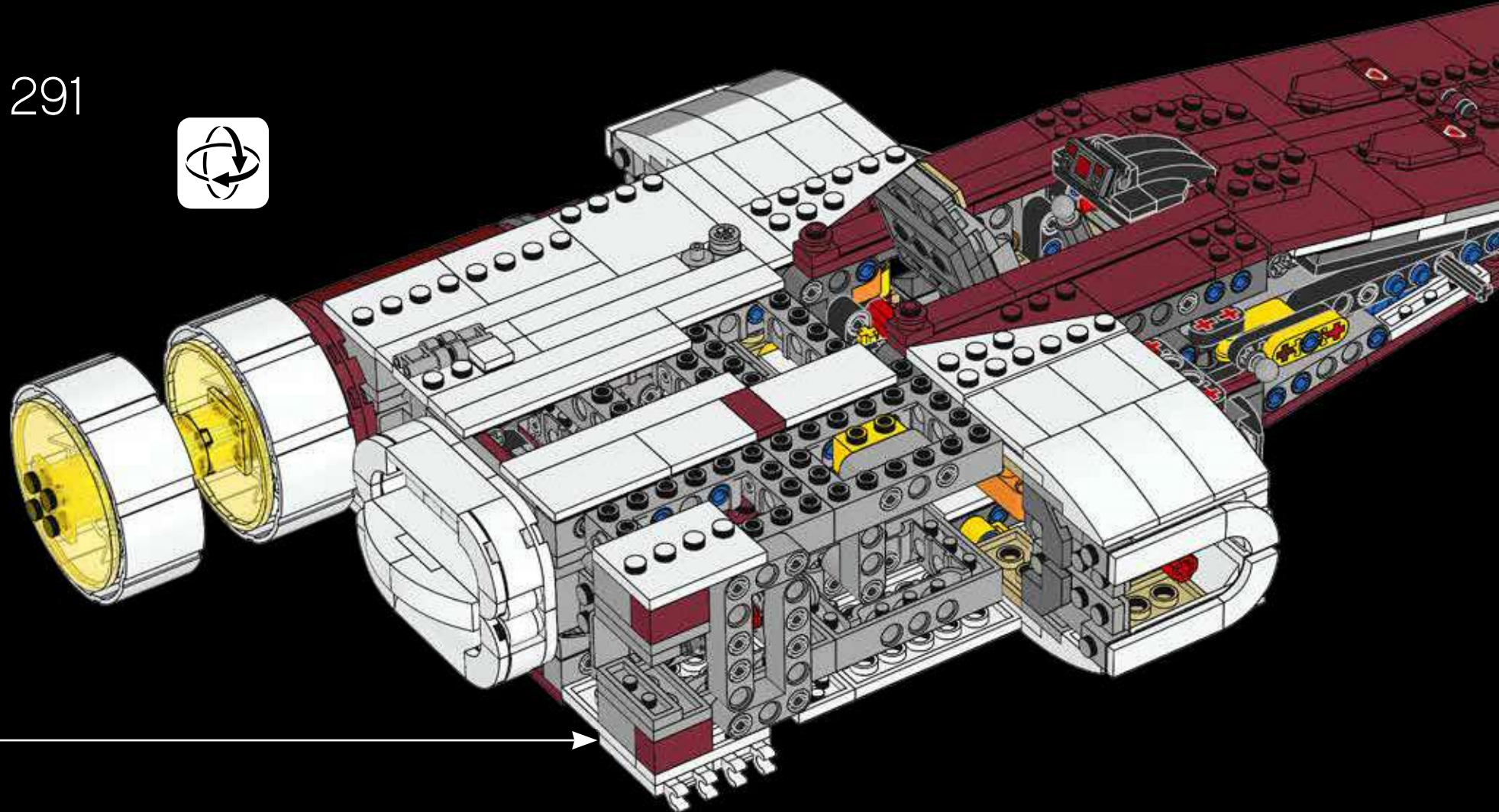

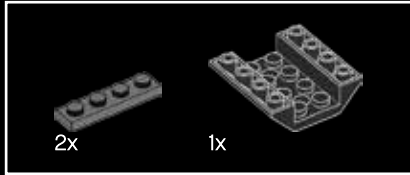

292

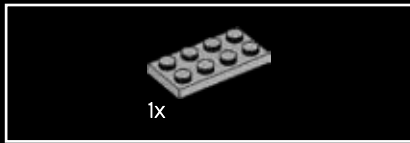
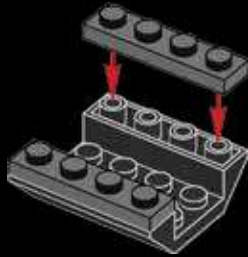

293

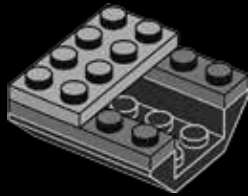

294

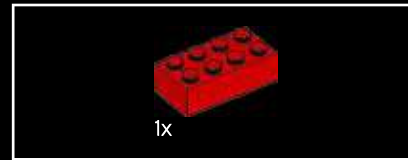
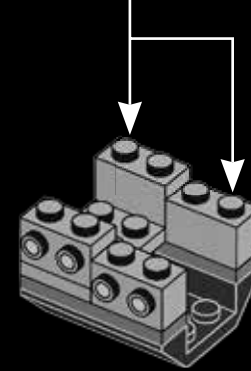
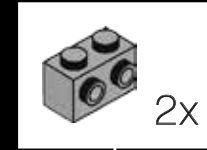

295

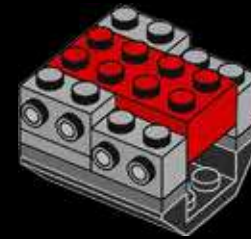



296

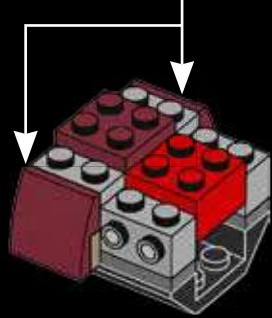
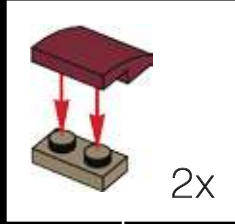

297

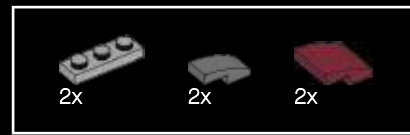
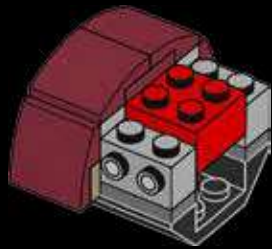

298

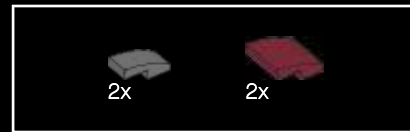
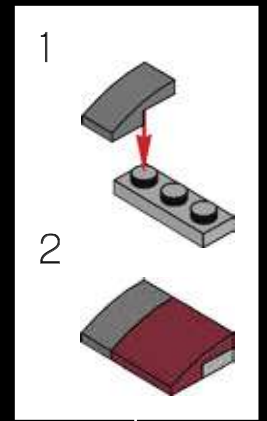
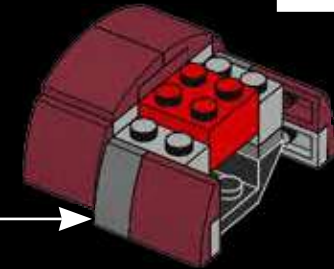
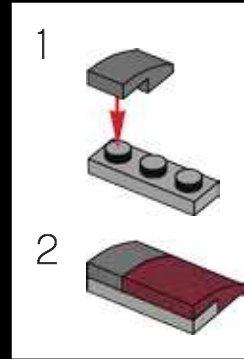

299

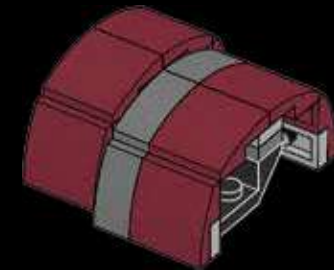



300

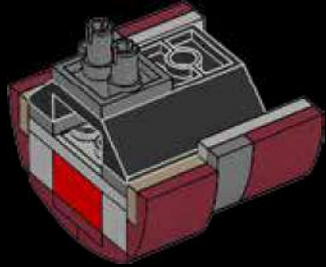

301

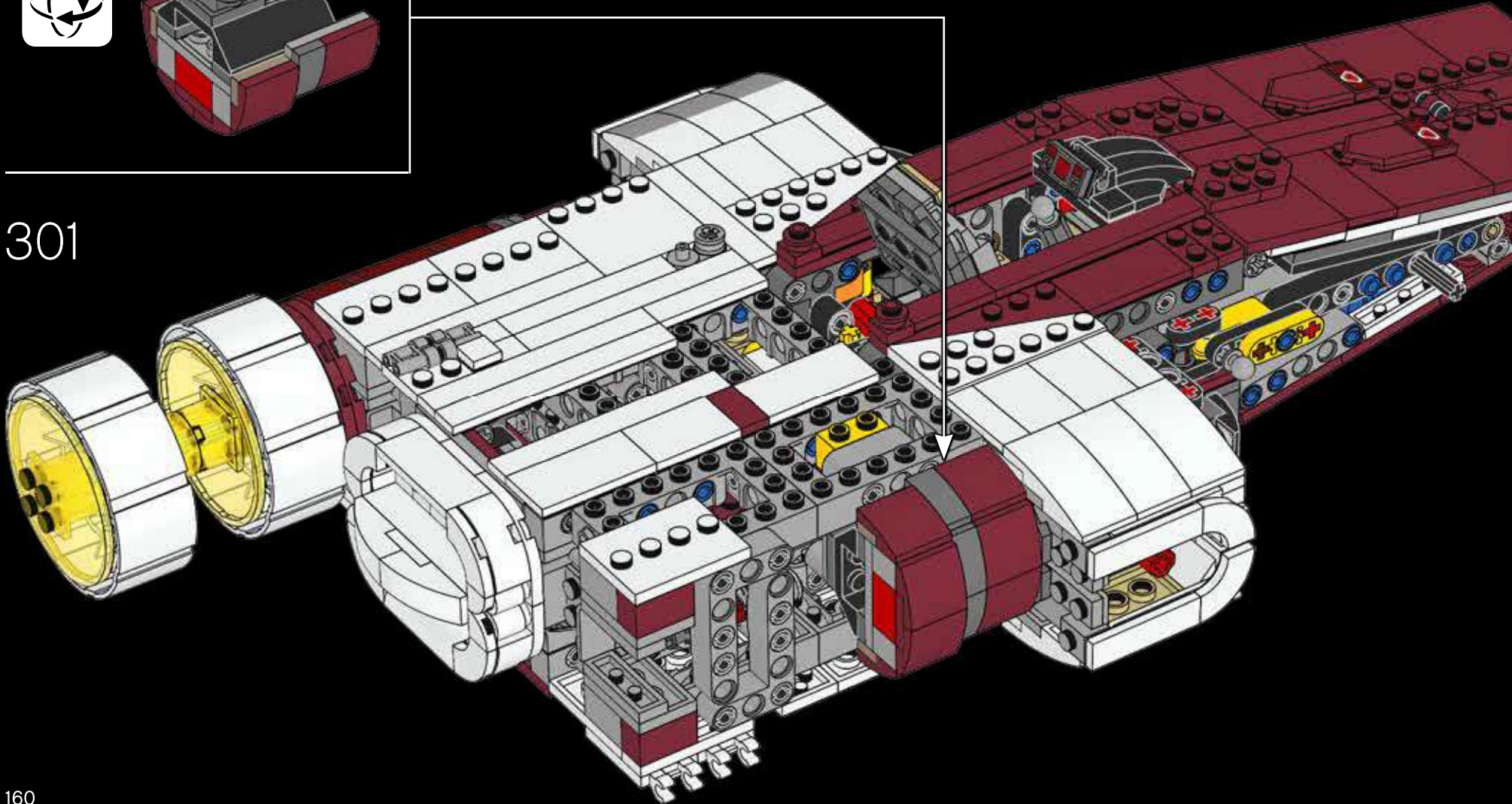



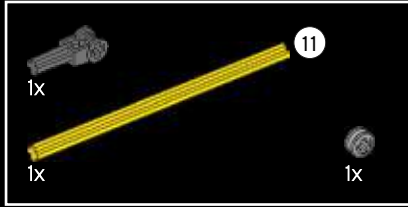
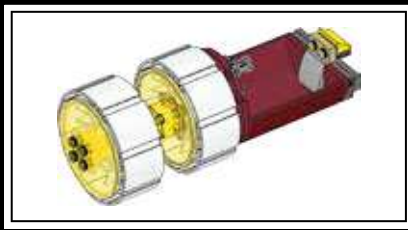

302

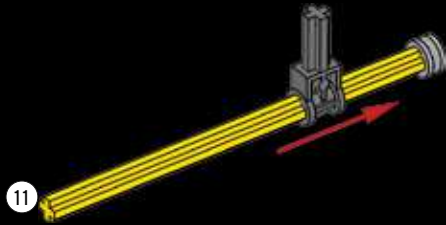

303

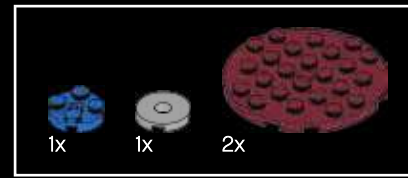

304

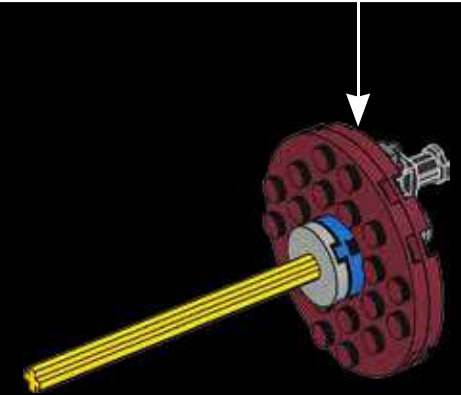
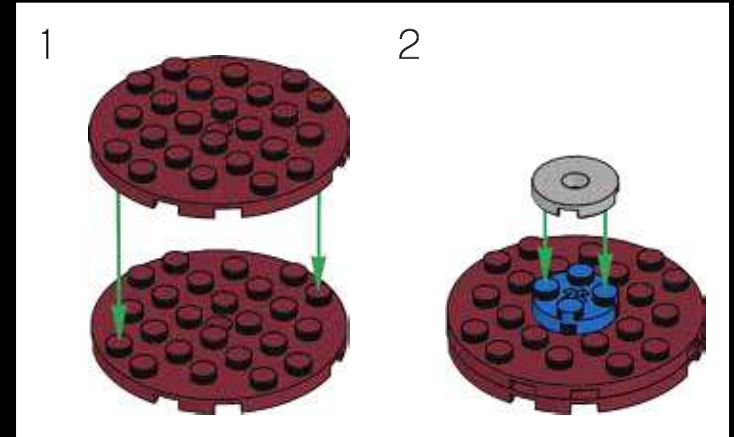

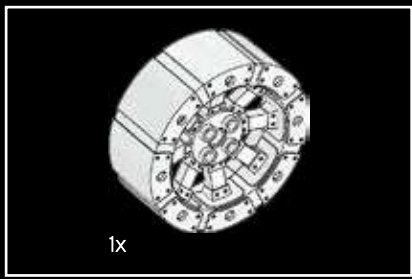

305

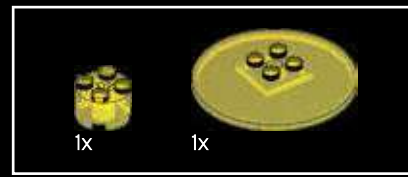
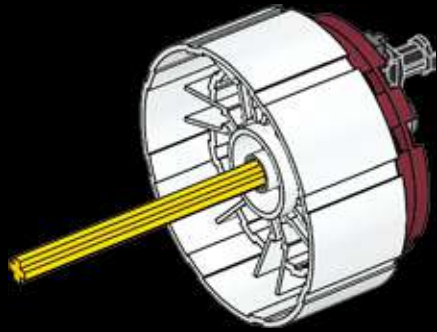

306

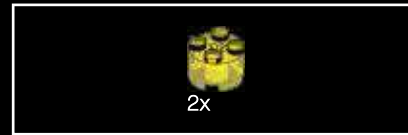
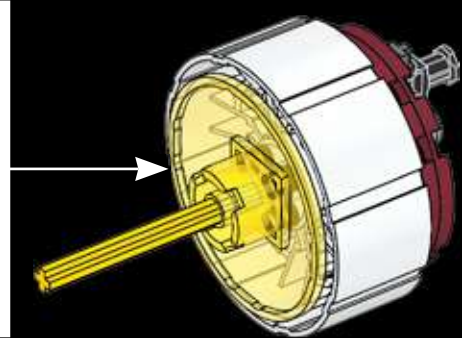
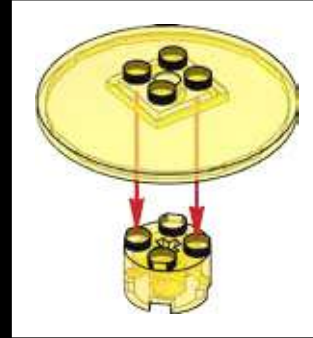

307

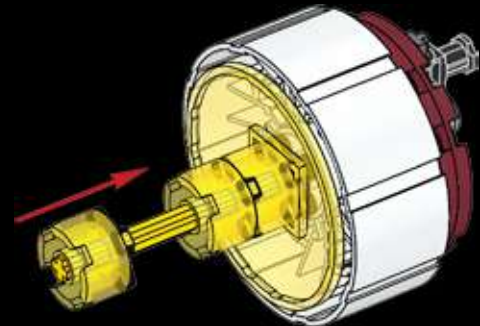

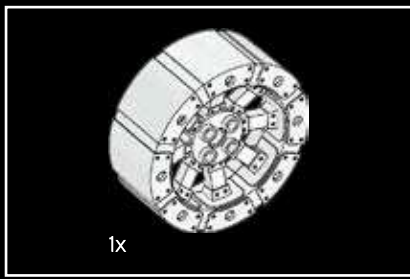

308

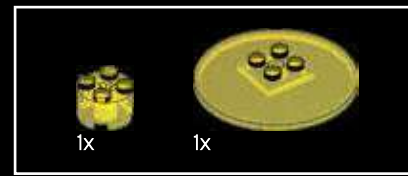
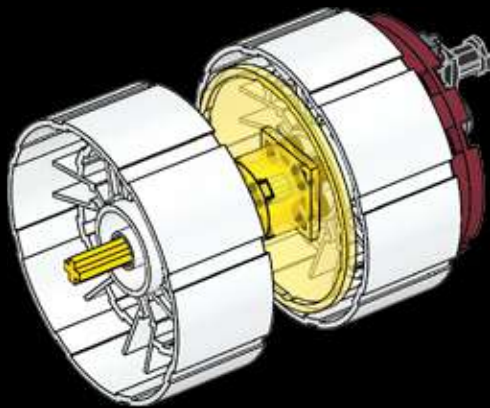

309

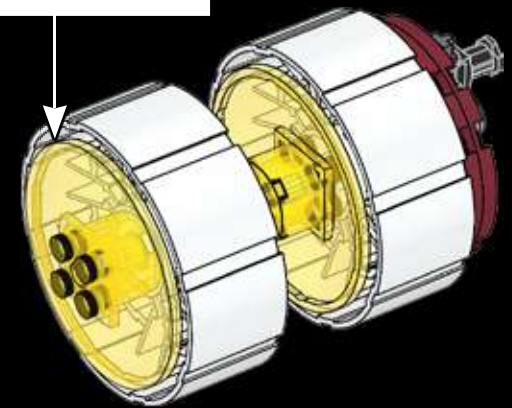
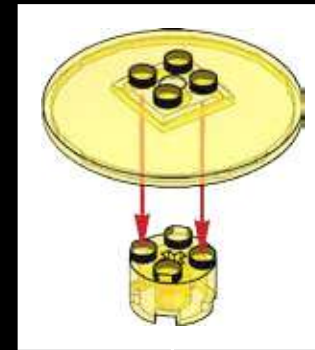



310



311



312



313

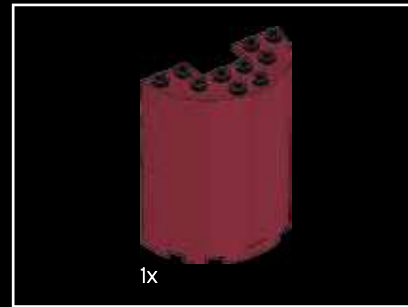

314



315

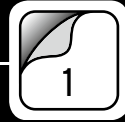

316



317

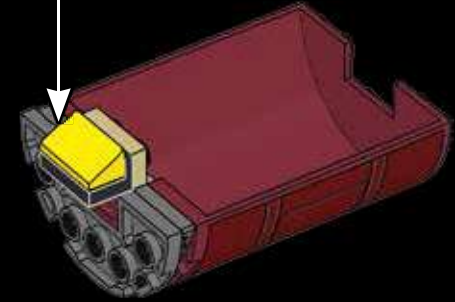
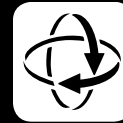
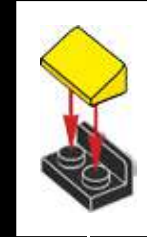

318

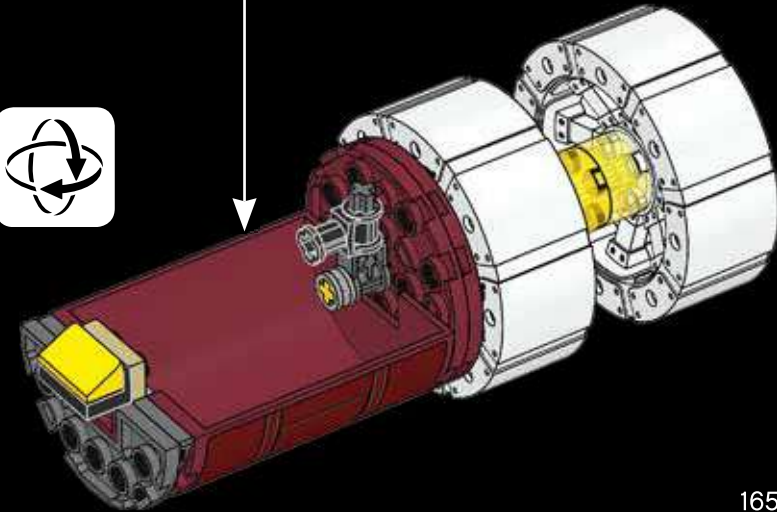
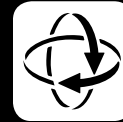

319

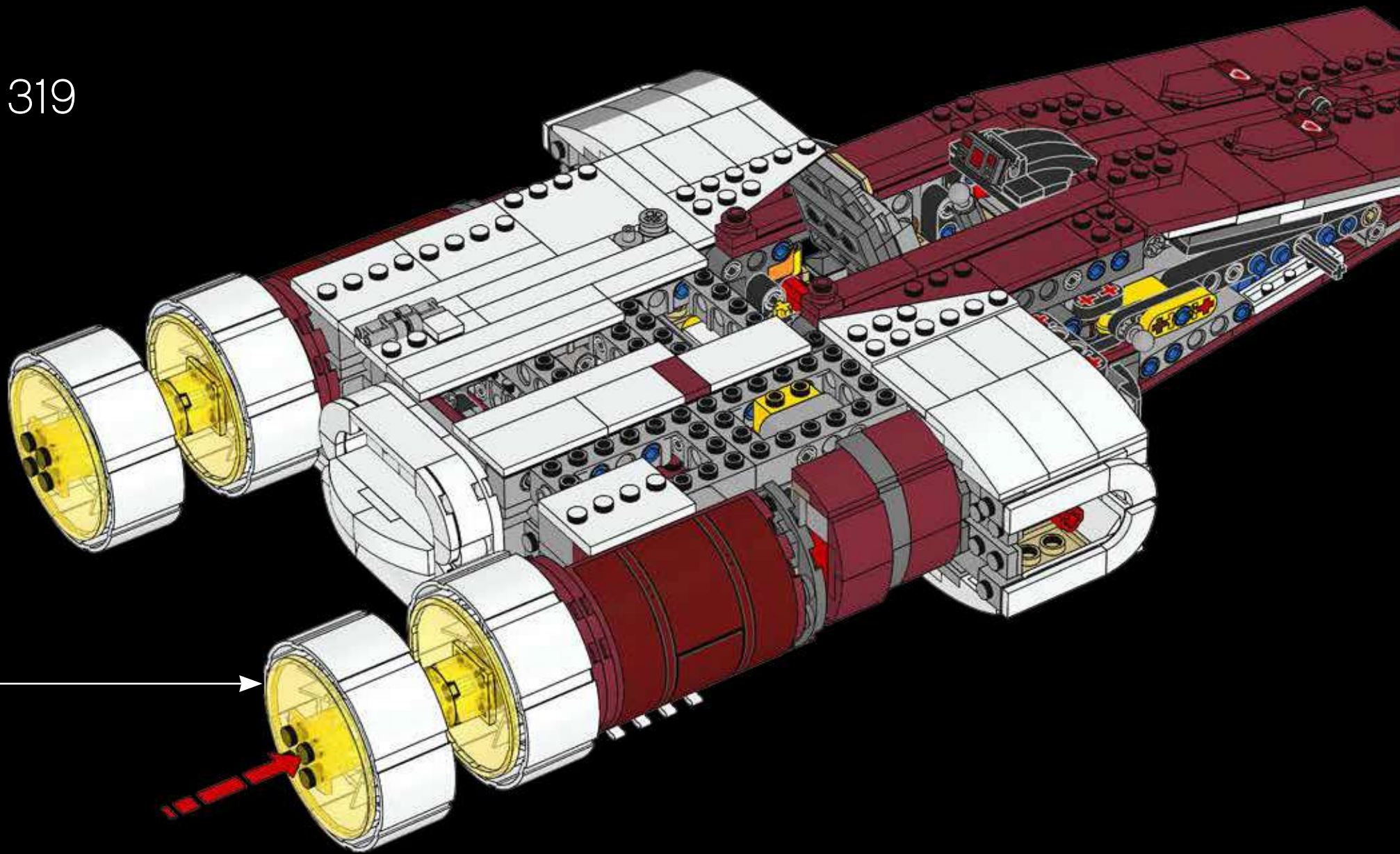

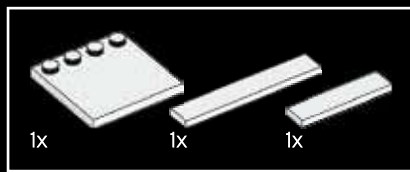

320

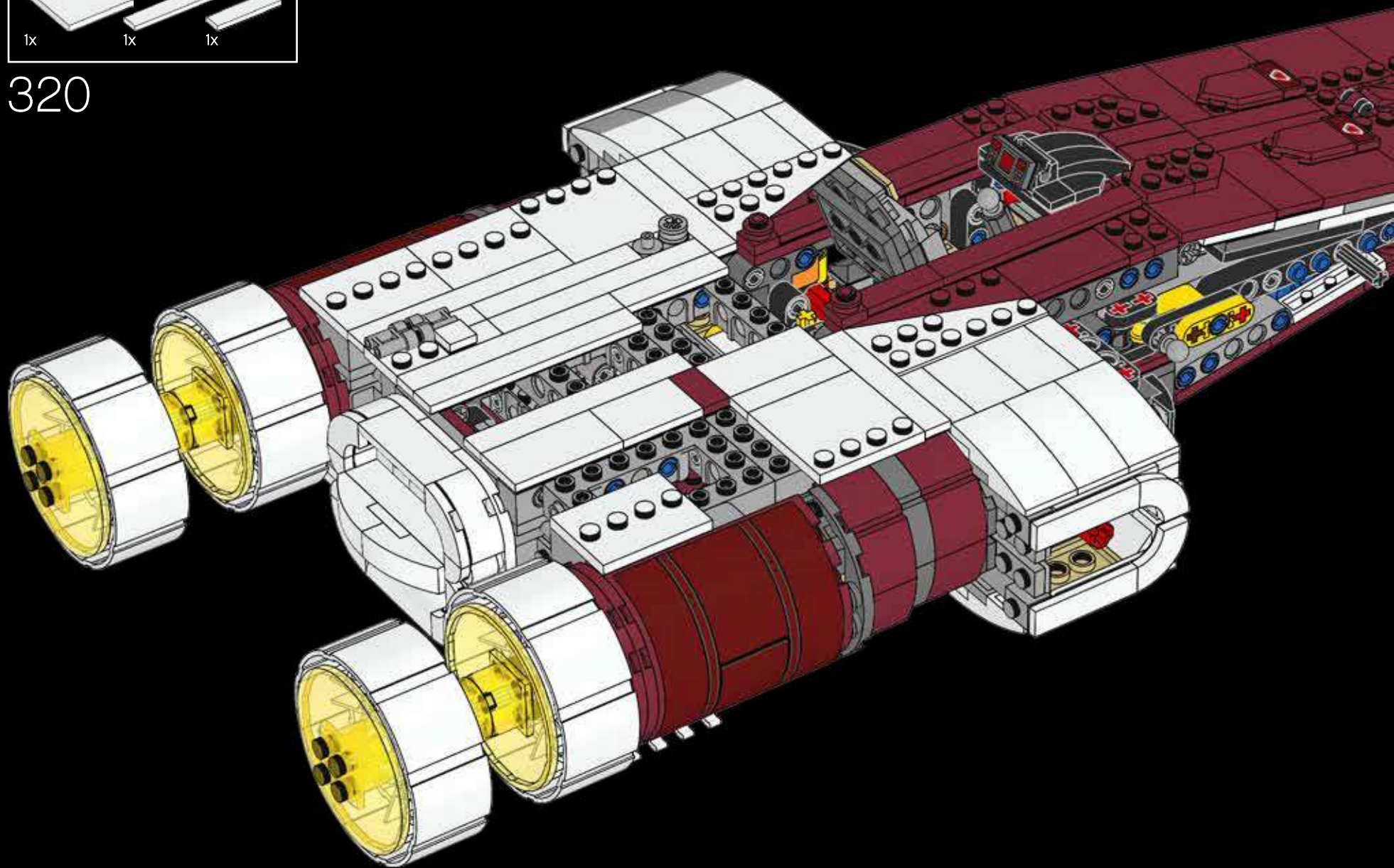

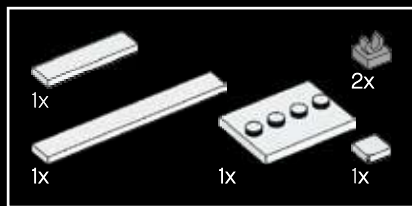

321

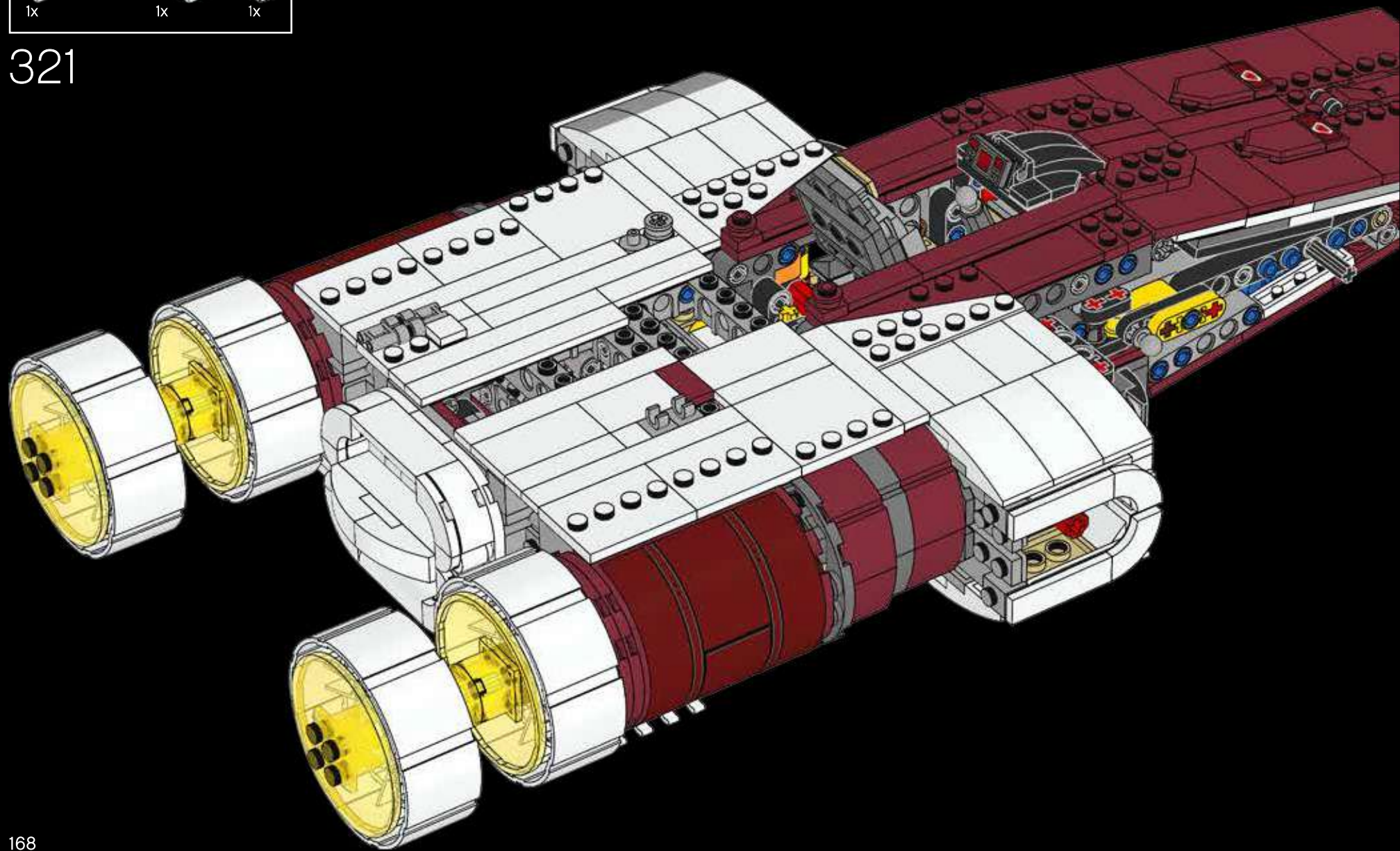



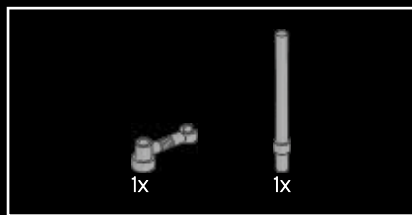

322

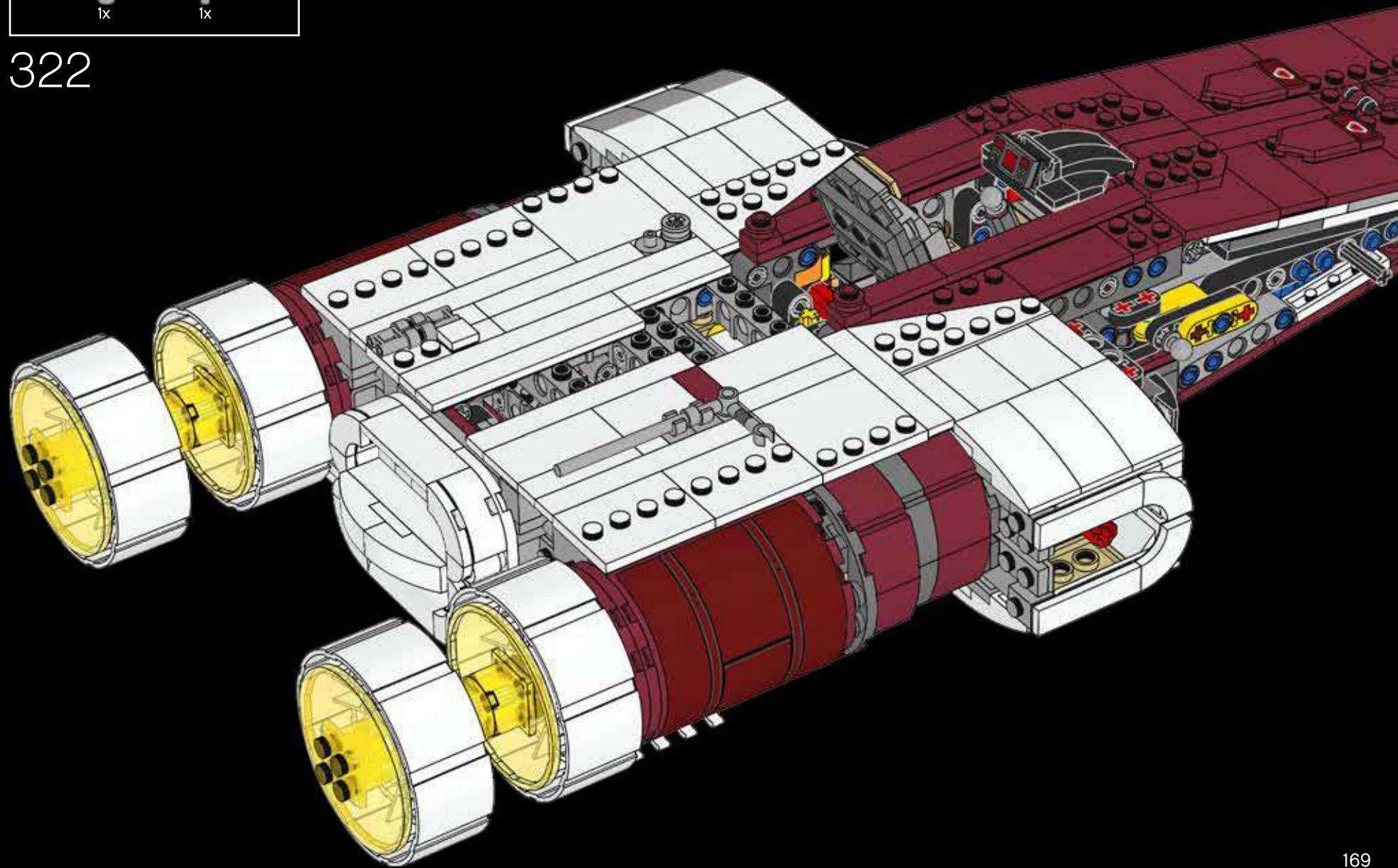

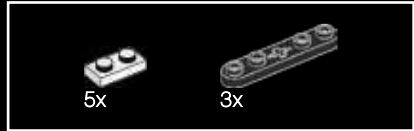
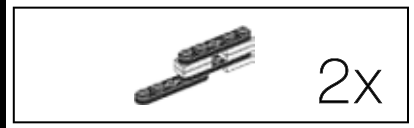
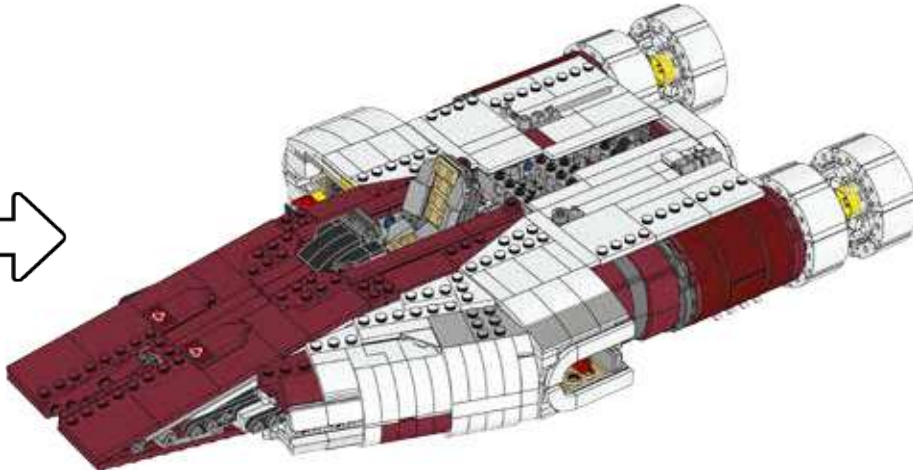
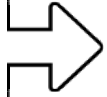

323

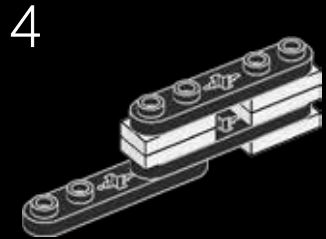
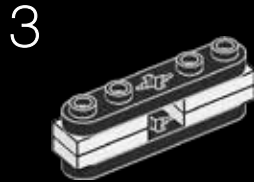
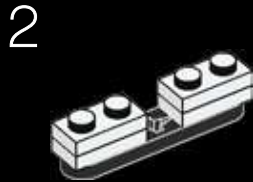
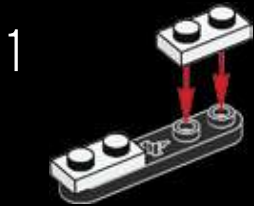

2x

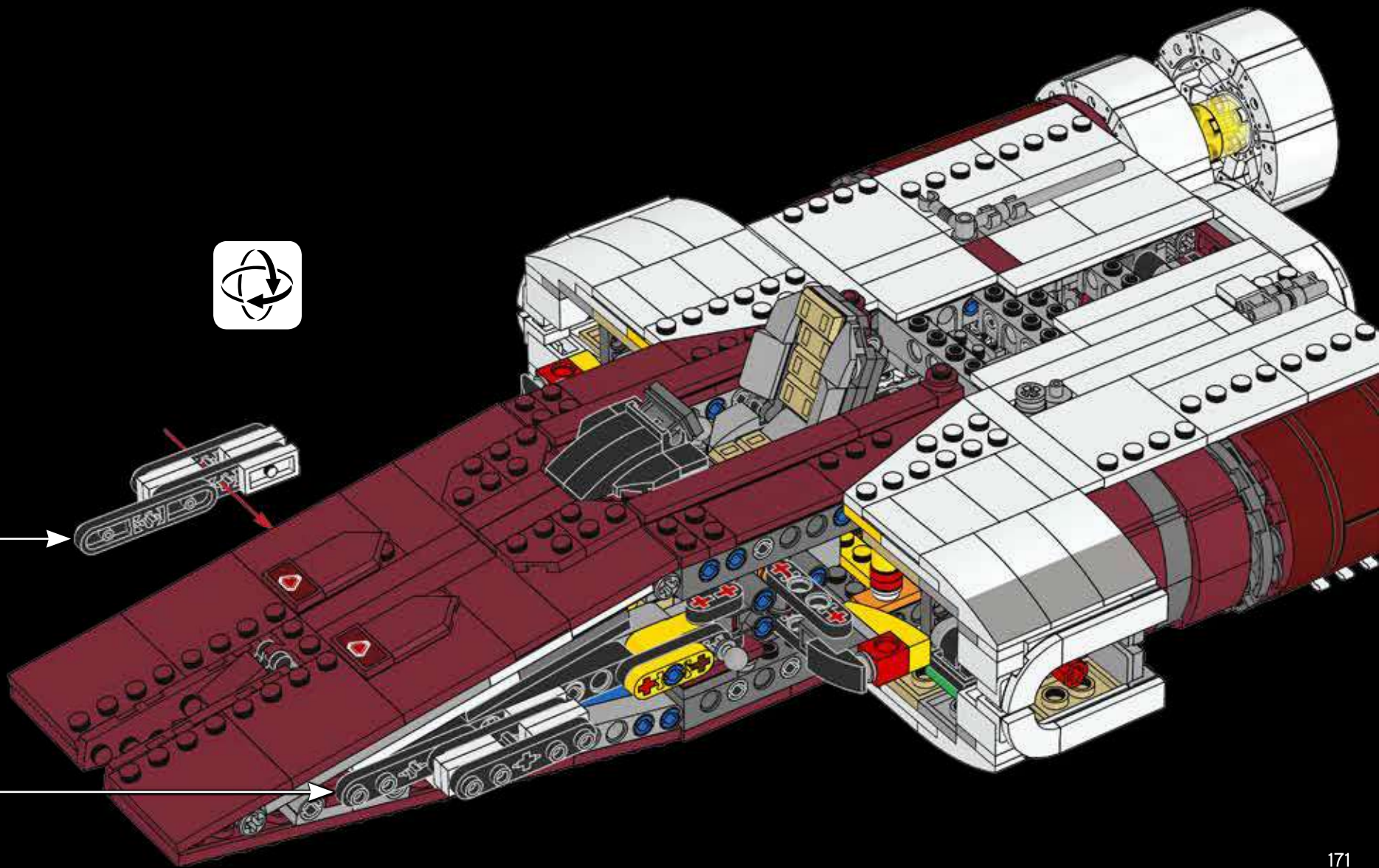
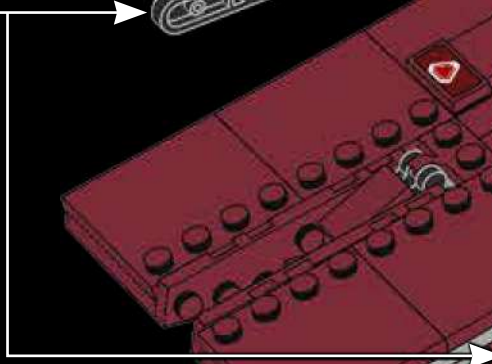

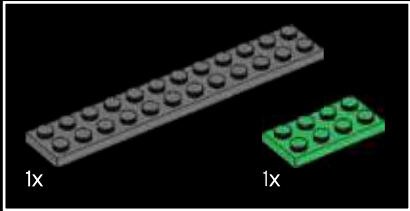
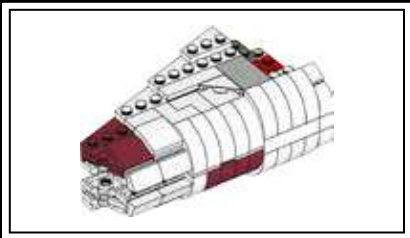

324

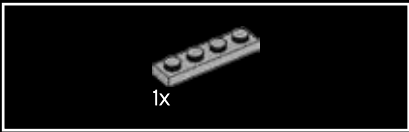
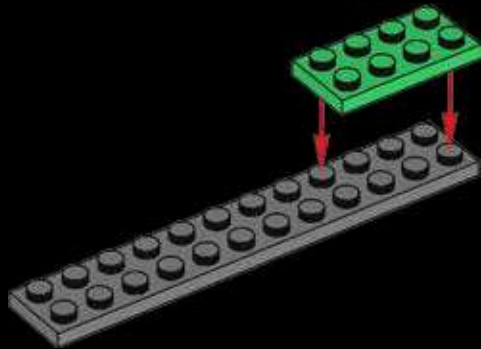

325

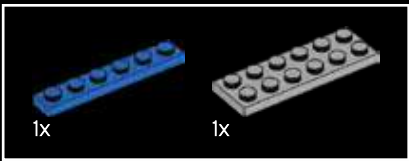
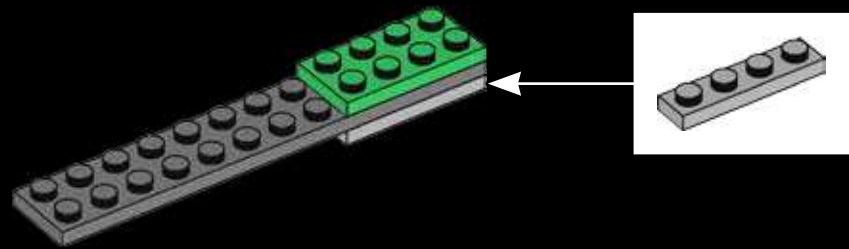

326

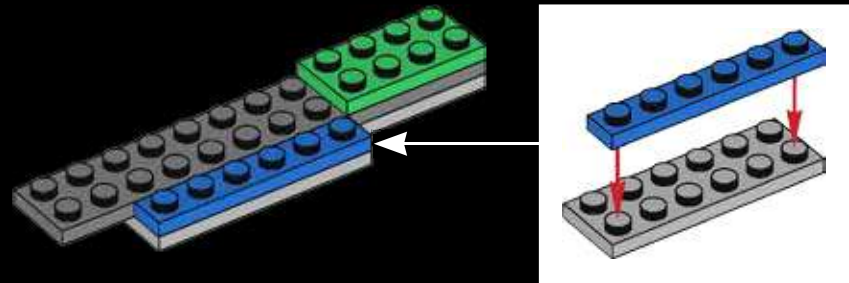



327

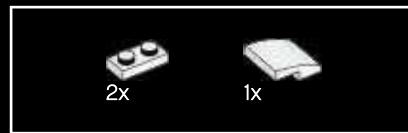
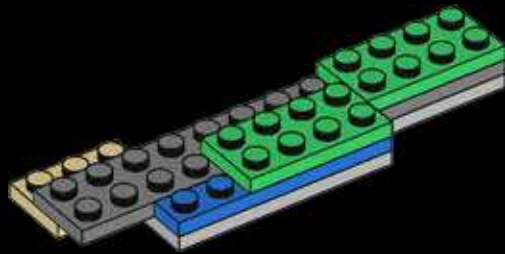

328

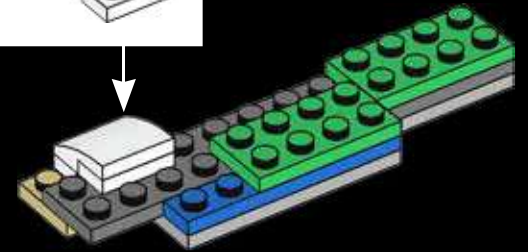
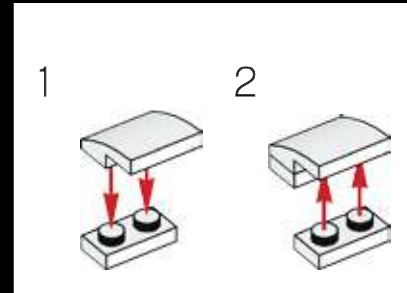

329

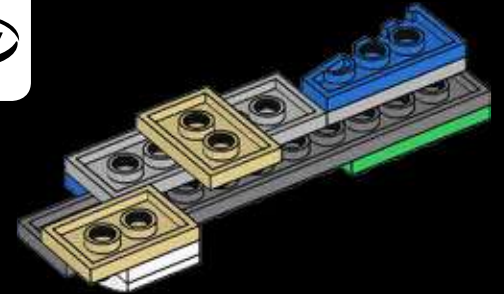
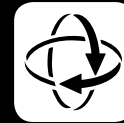



330

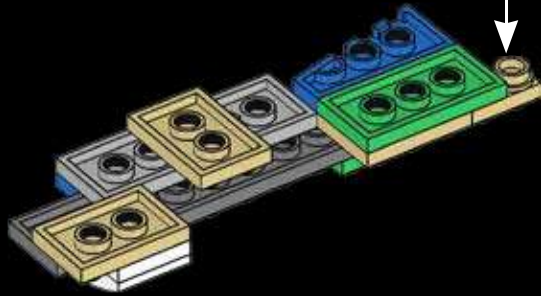
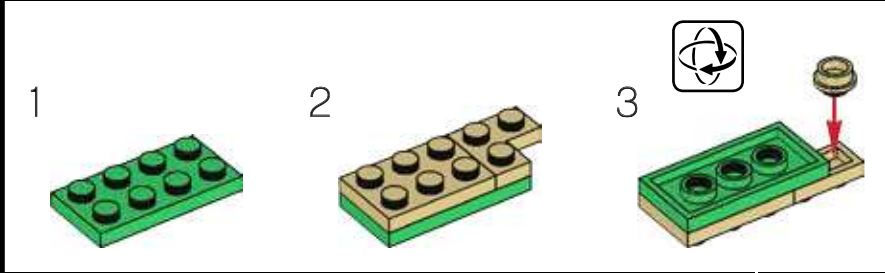

331

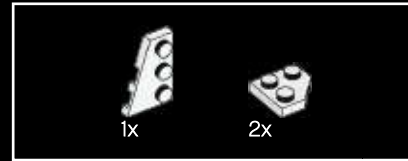
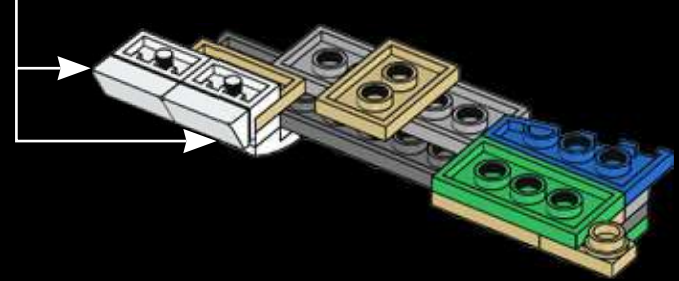
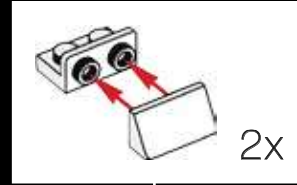

332

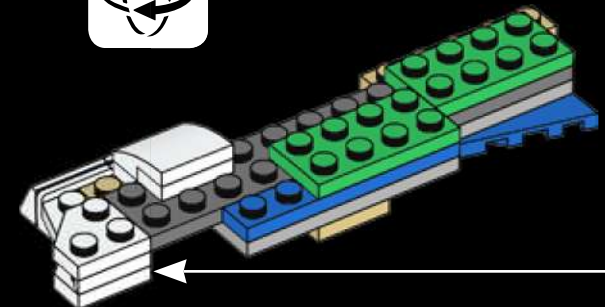
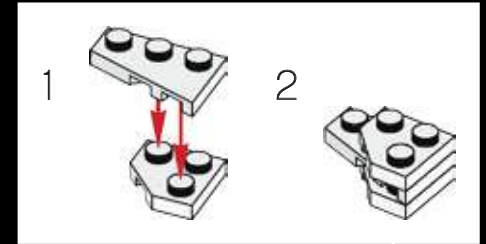

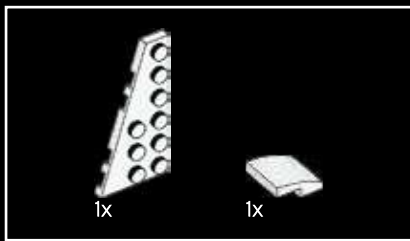

1x

1x

# 333

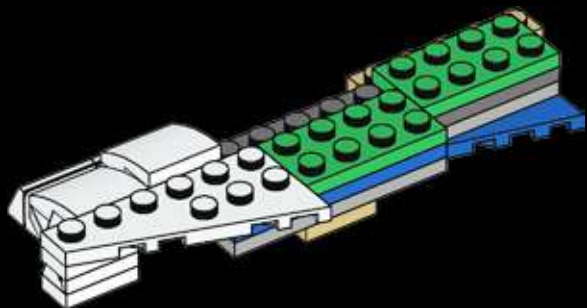

2x

# 334

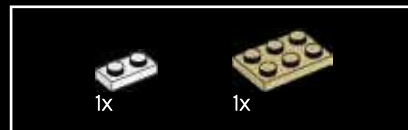
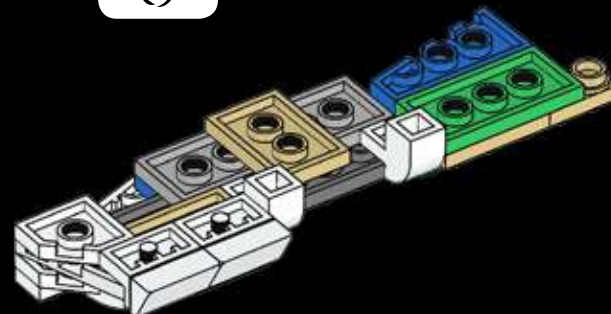

1x

1x

# 335

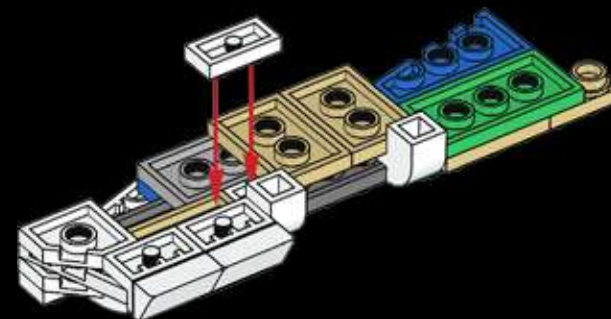



336

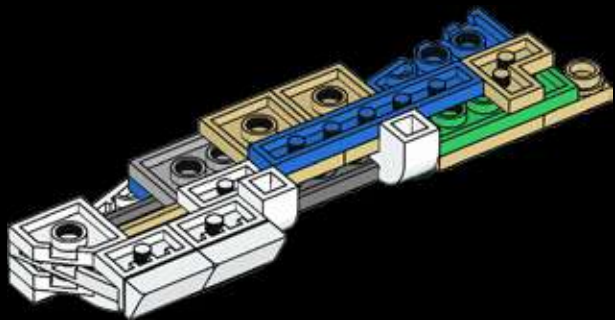

337

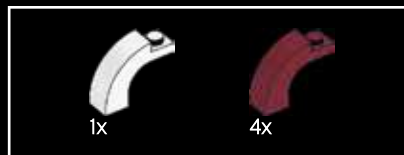
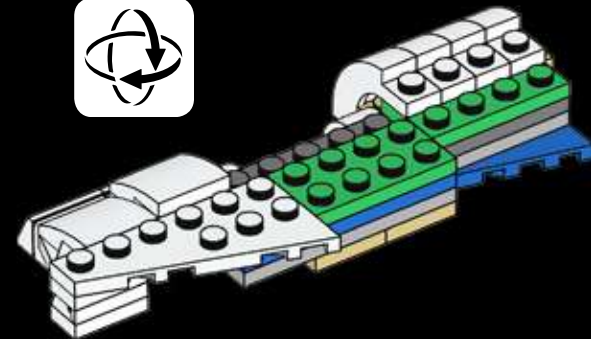

338

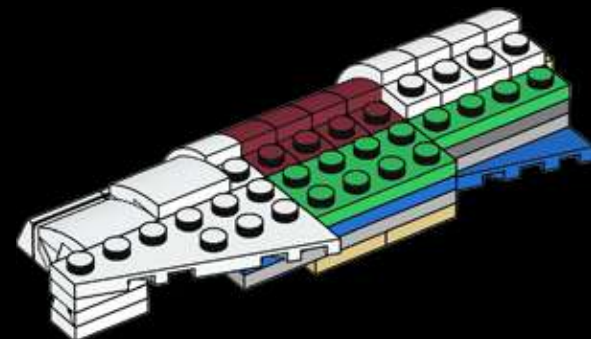



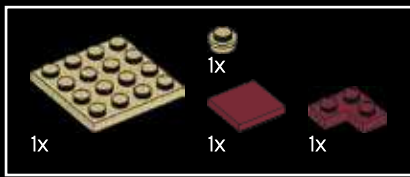

339

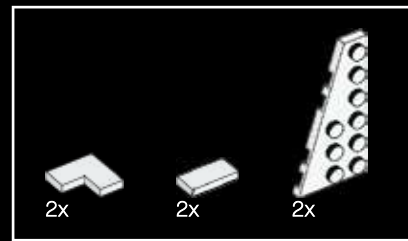
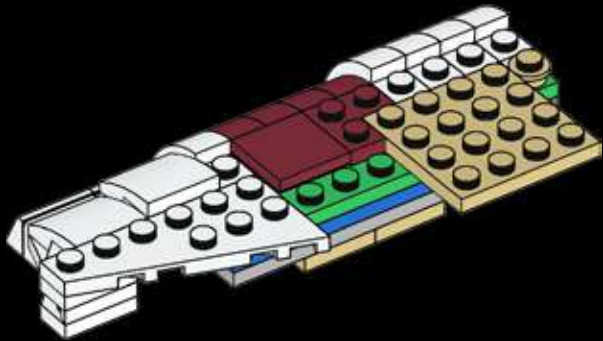

340

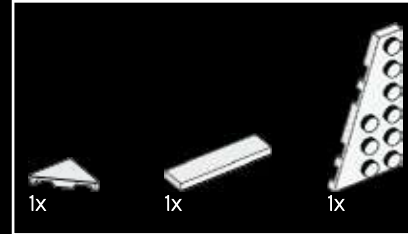
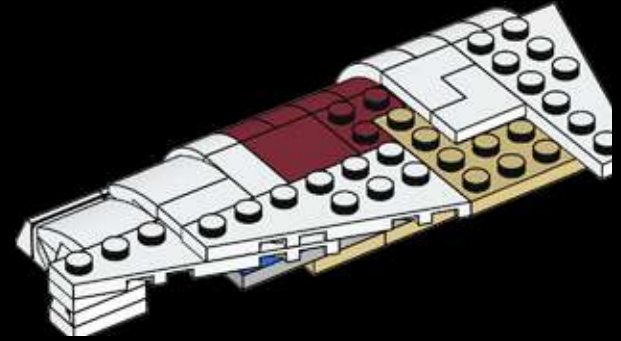

341

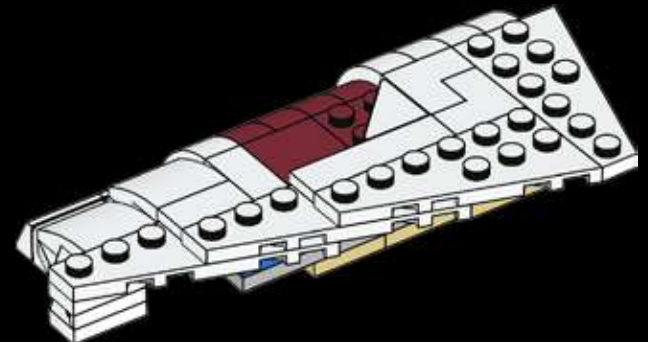



2x

342

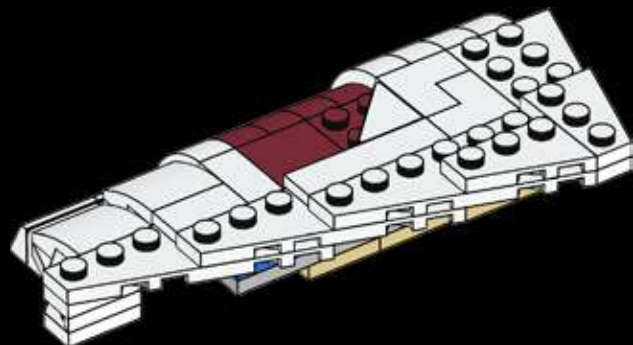

1x



2x



2x

343

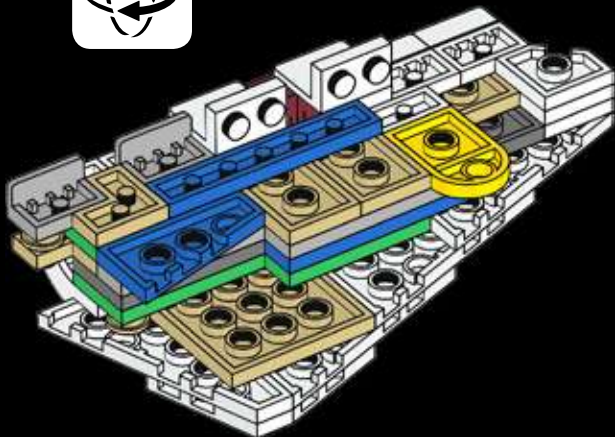

1x

1x

1x

1x

344

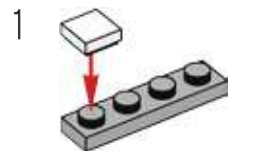

1

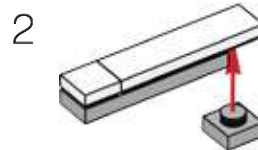

2

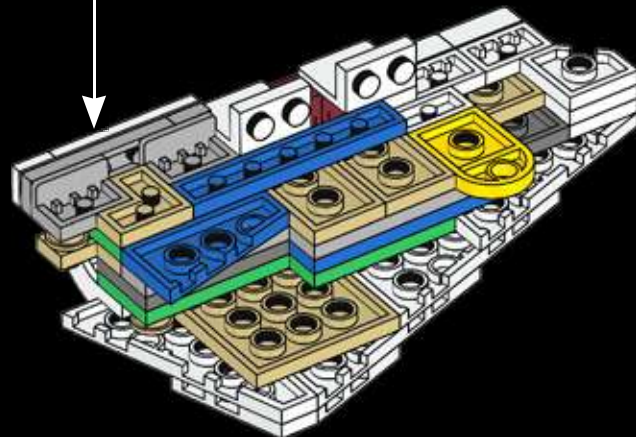

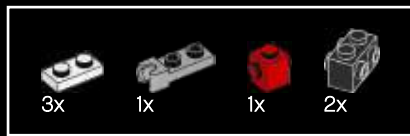

345

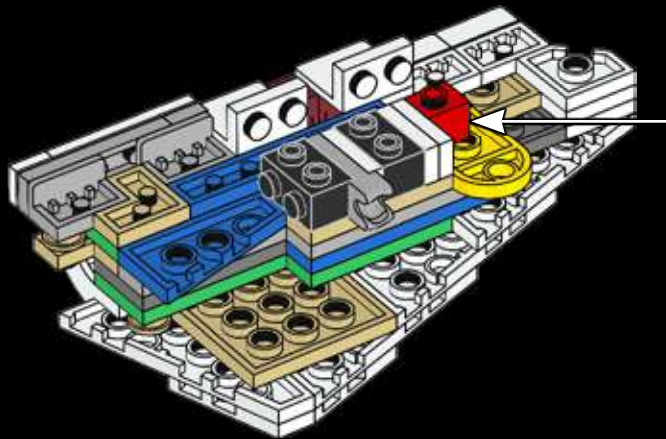
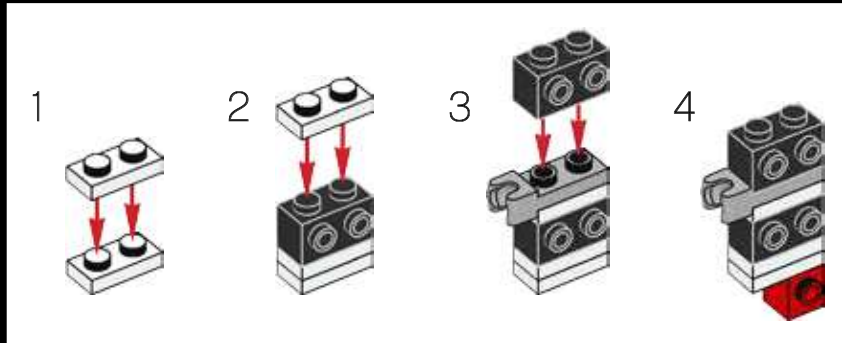

346

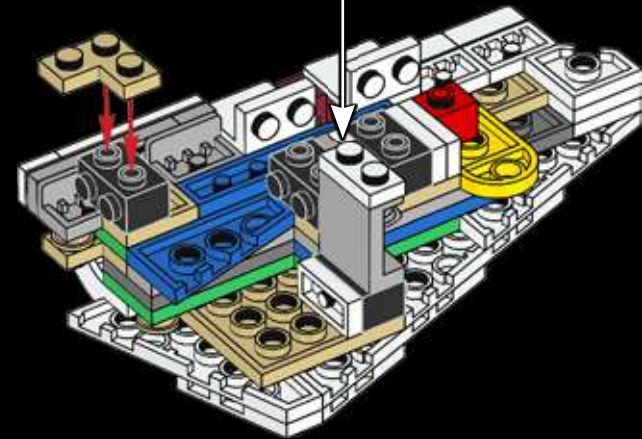
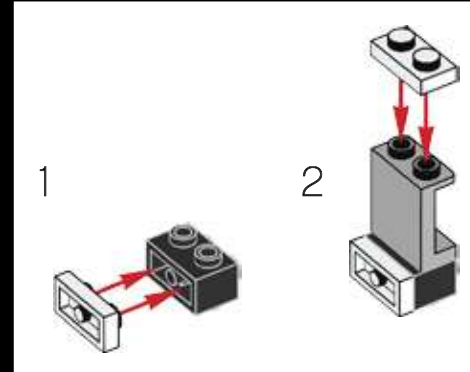

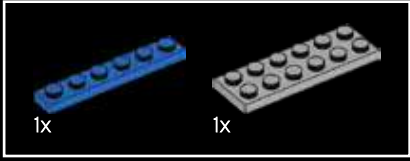
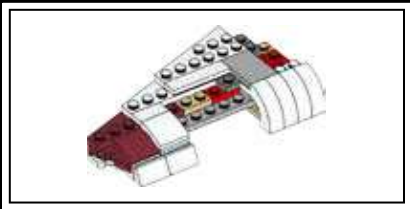

347

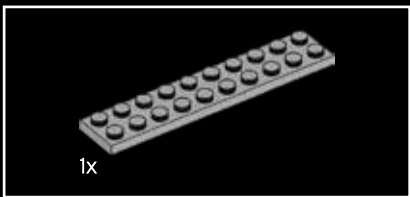
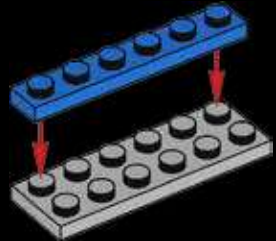

348

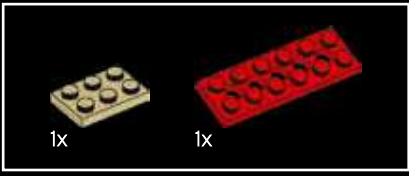
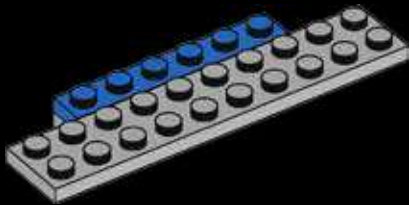

349

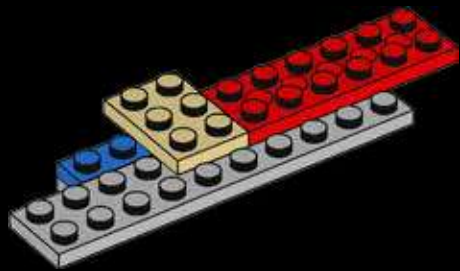

350

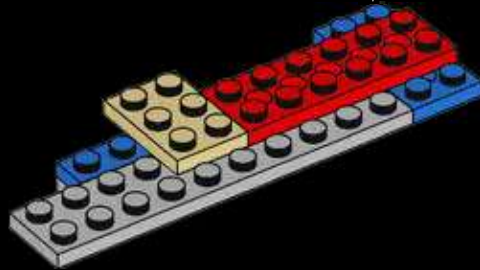
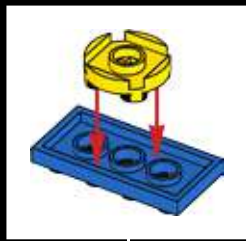



351

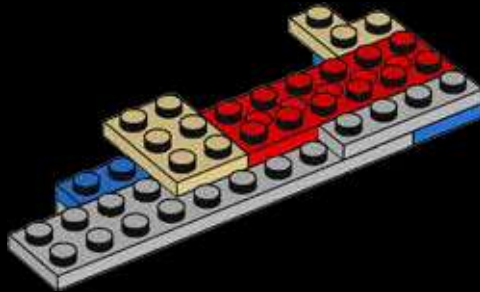

352

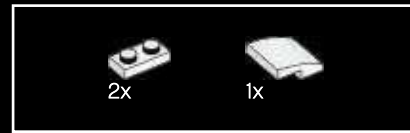
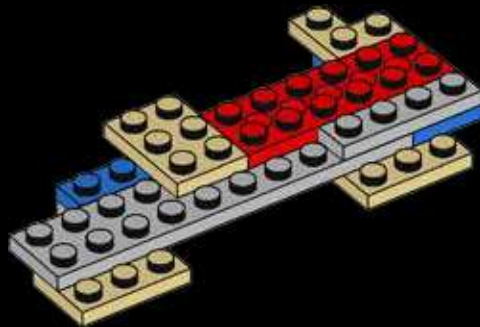

353

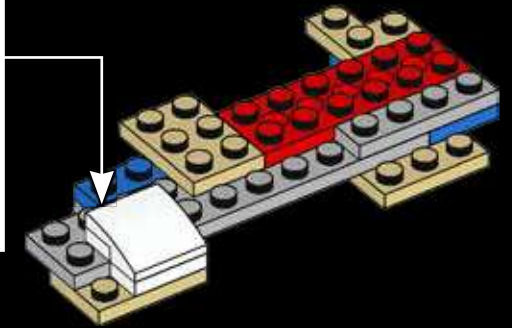
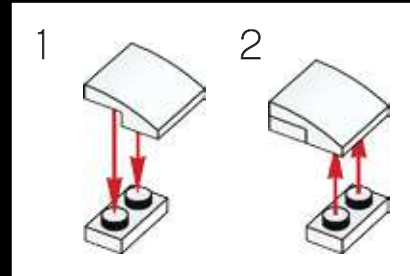

354

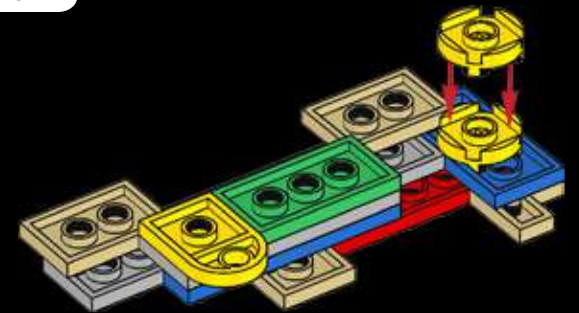

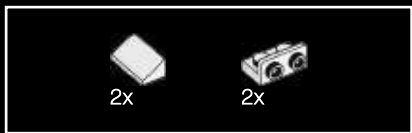

355

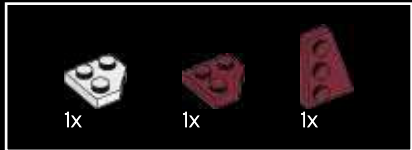
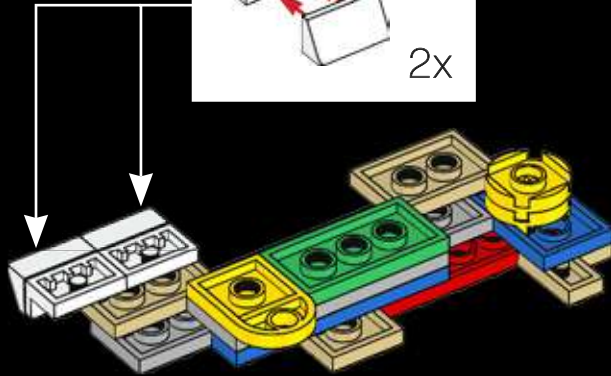
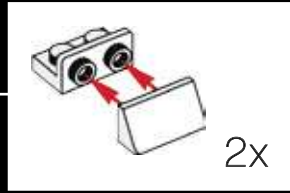

356

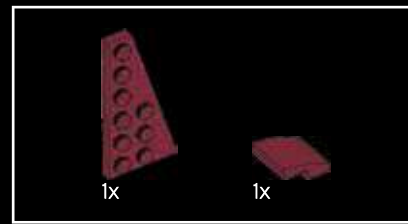
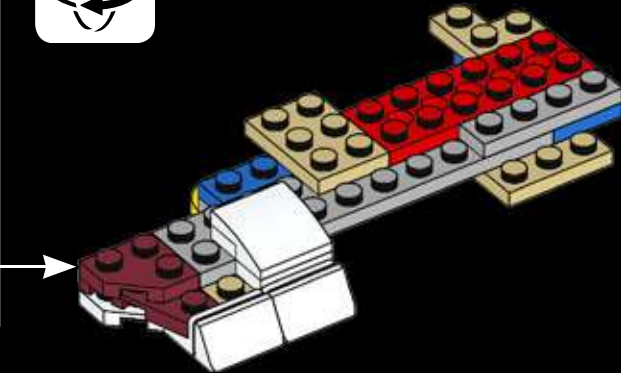
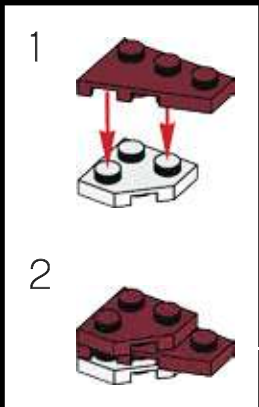

357

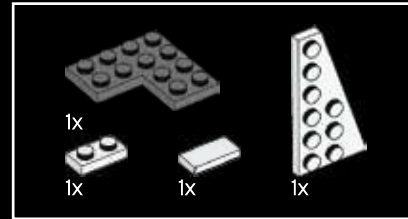
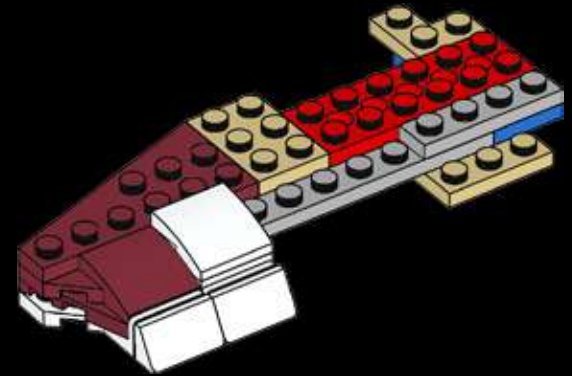

358

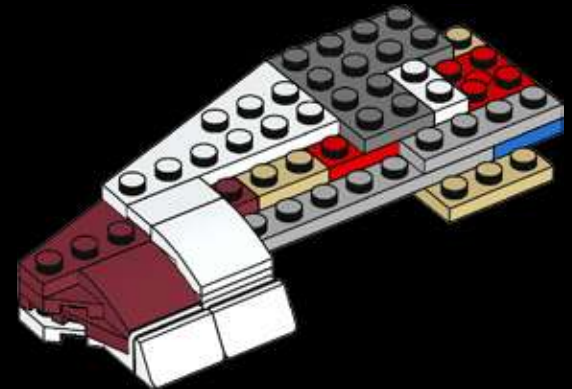



359

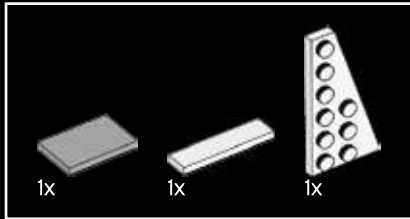
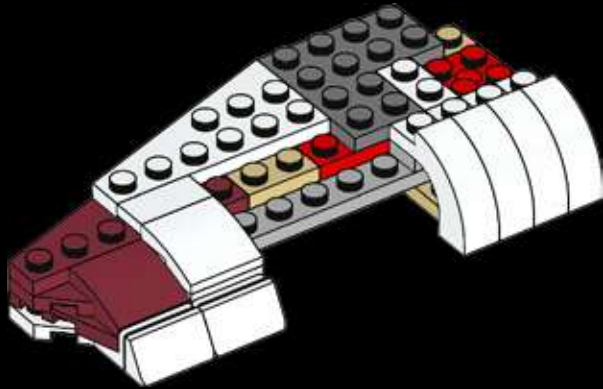

360

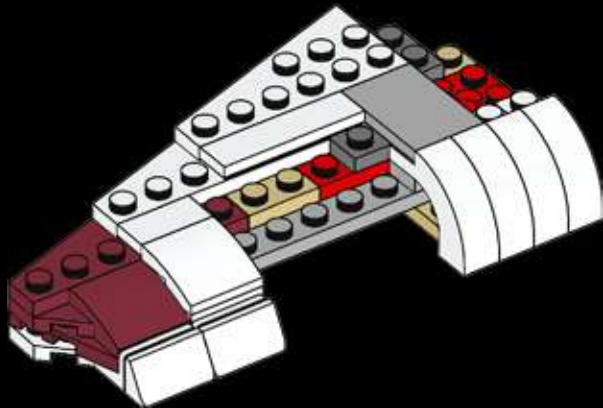

361

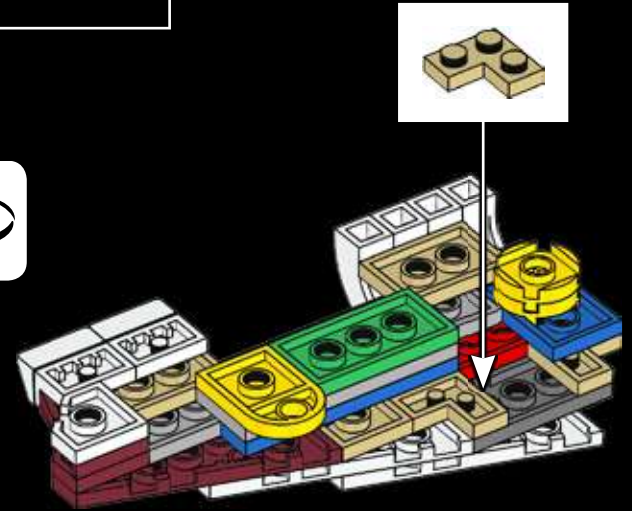

362

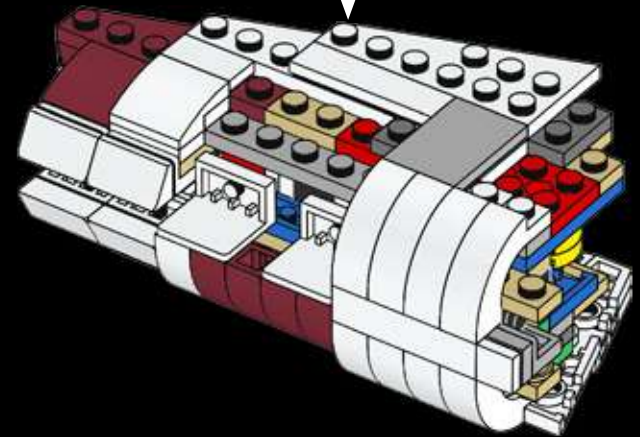



363

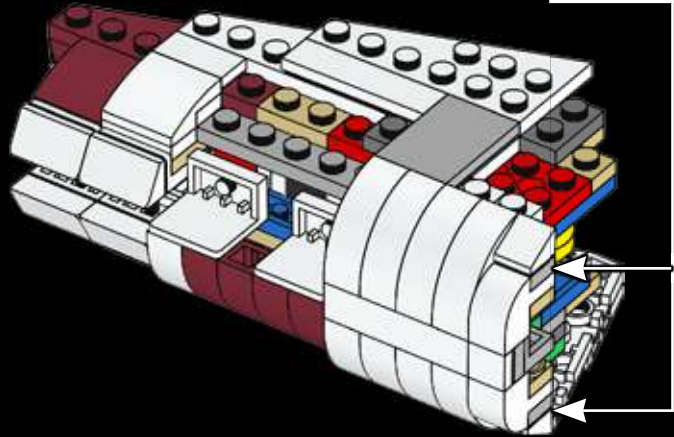
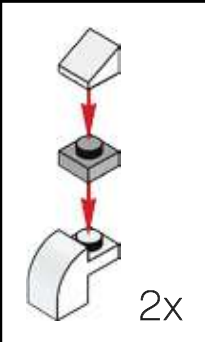

364

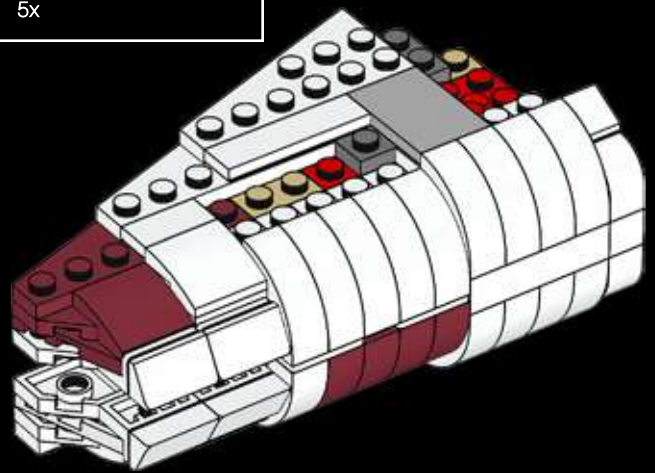

365

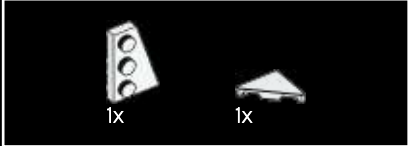
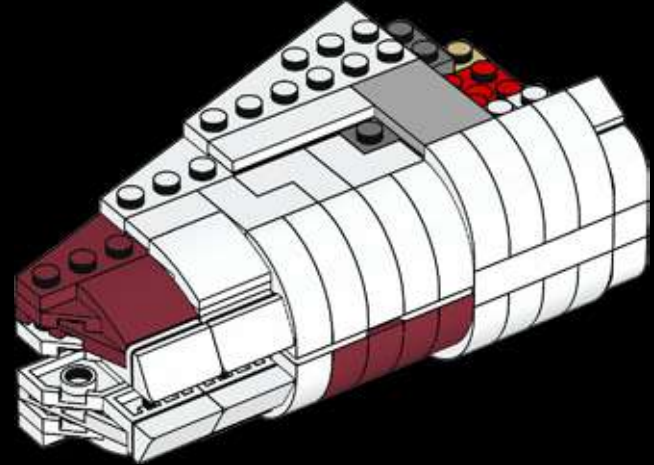

366

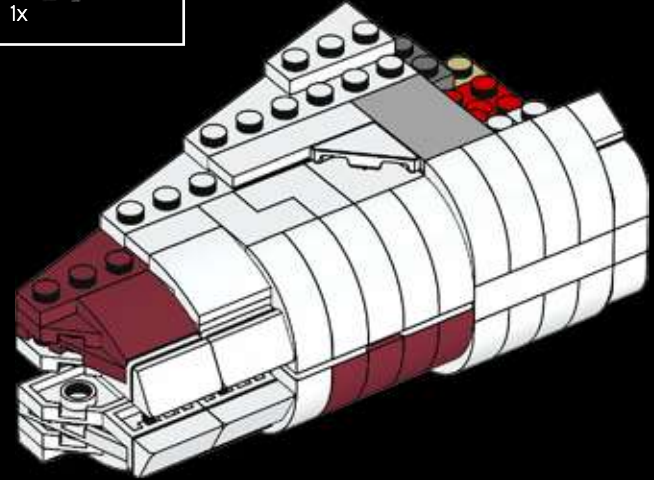



367

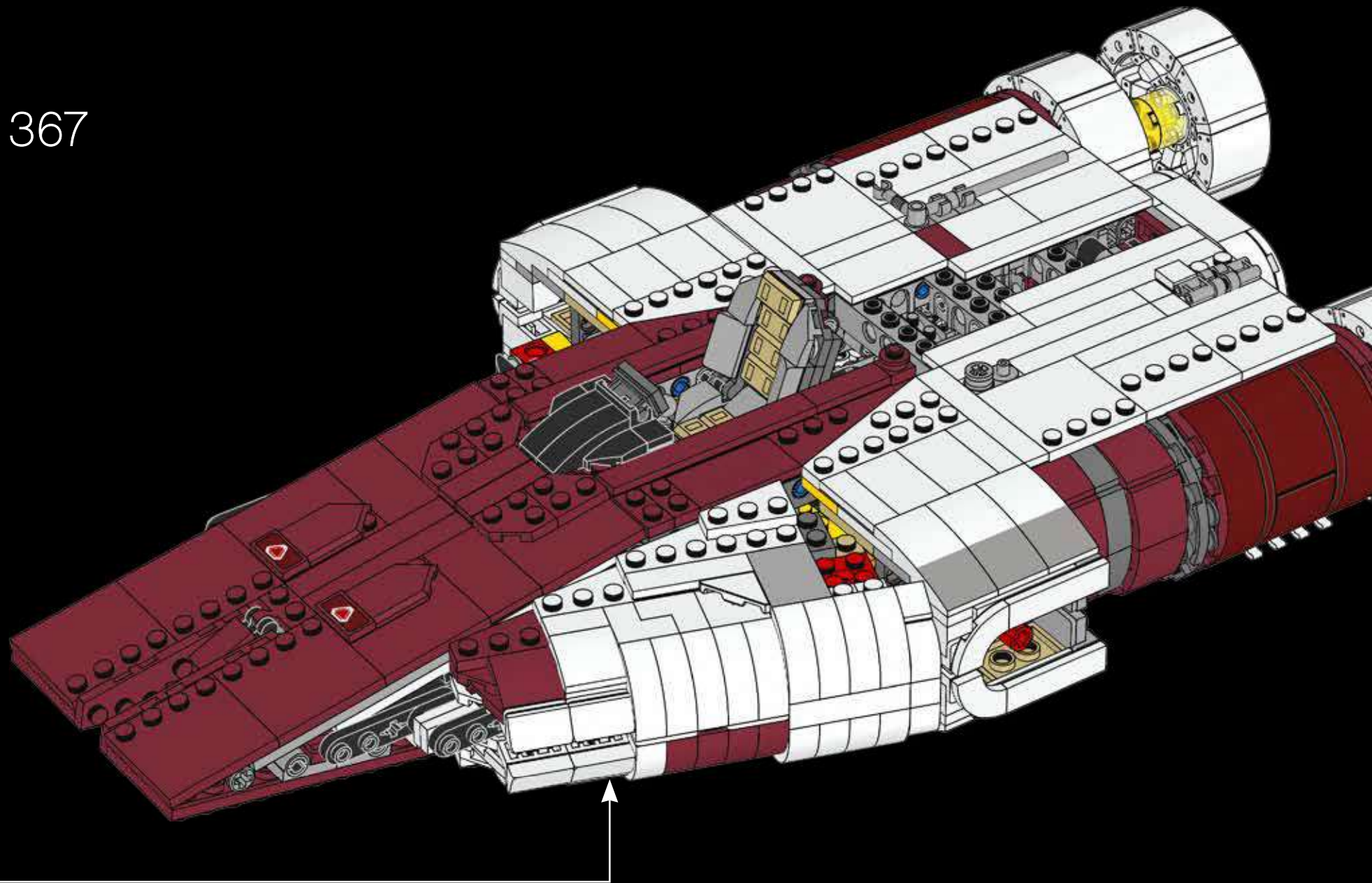



368

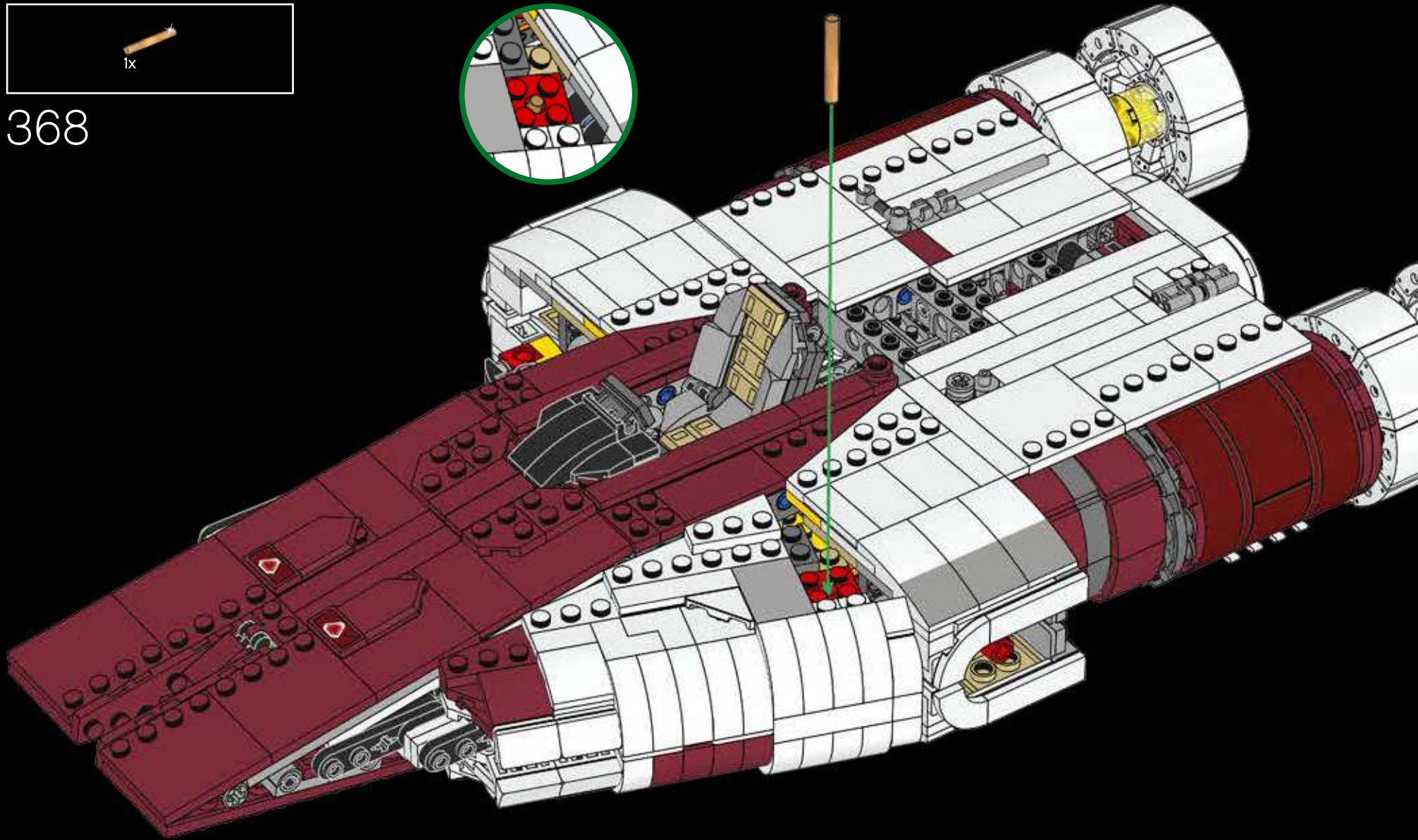
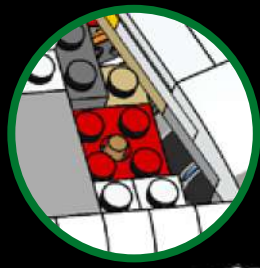

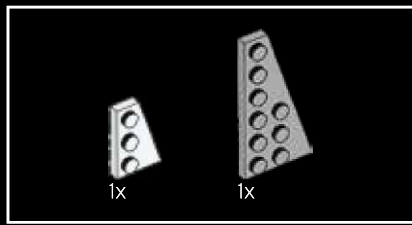

369

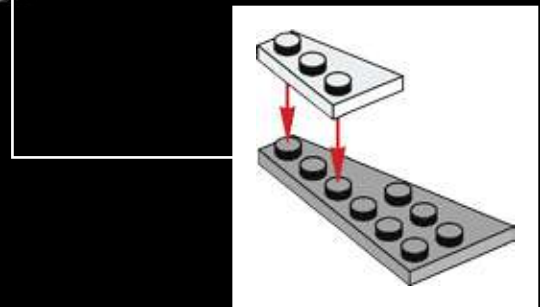
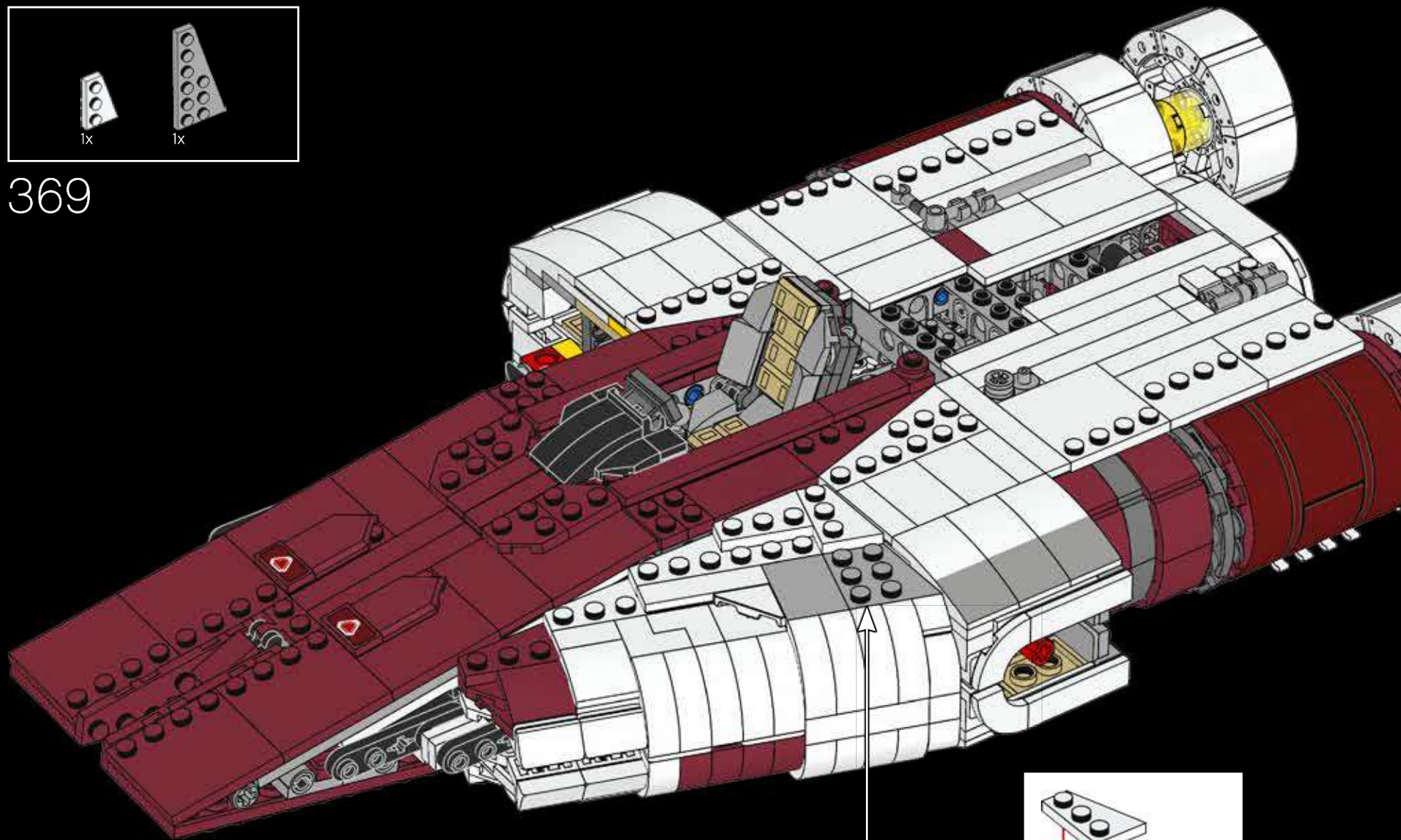

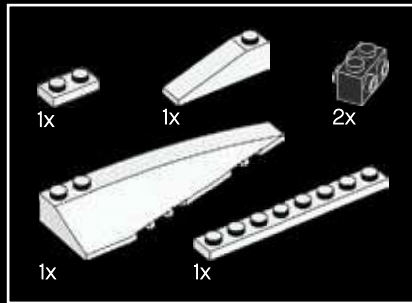
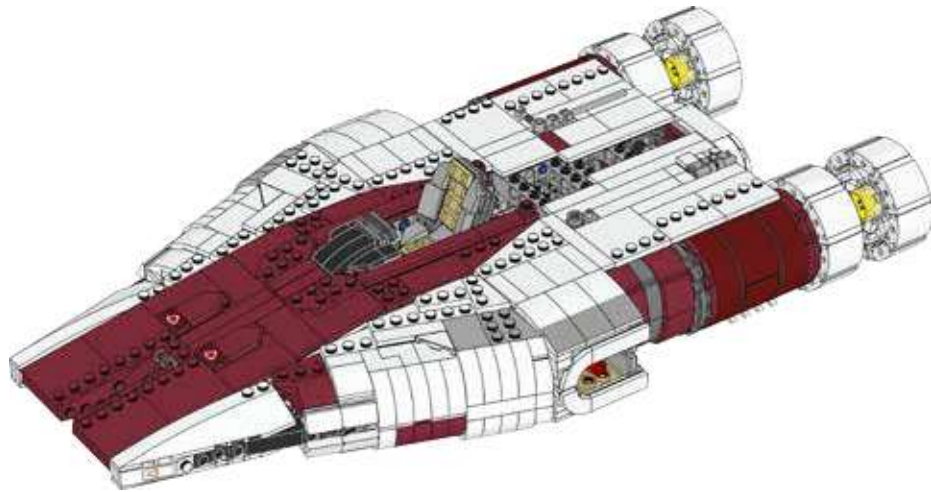
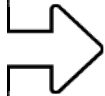

370

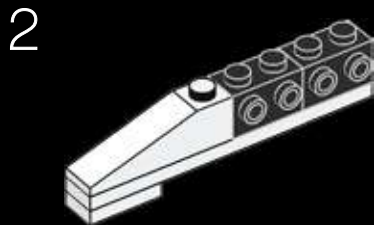
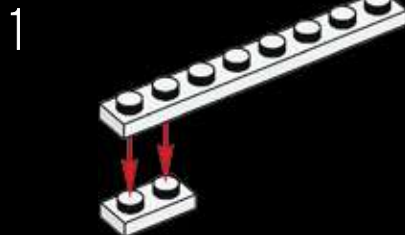

3

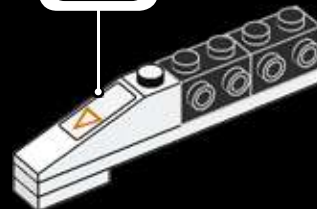

4

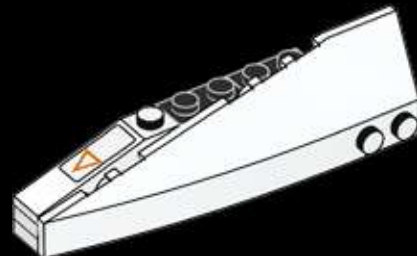

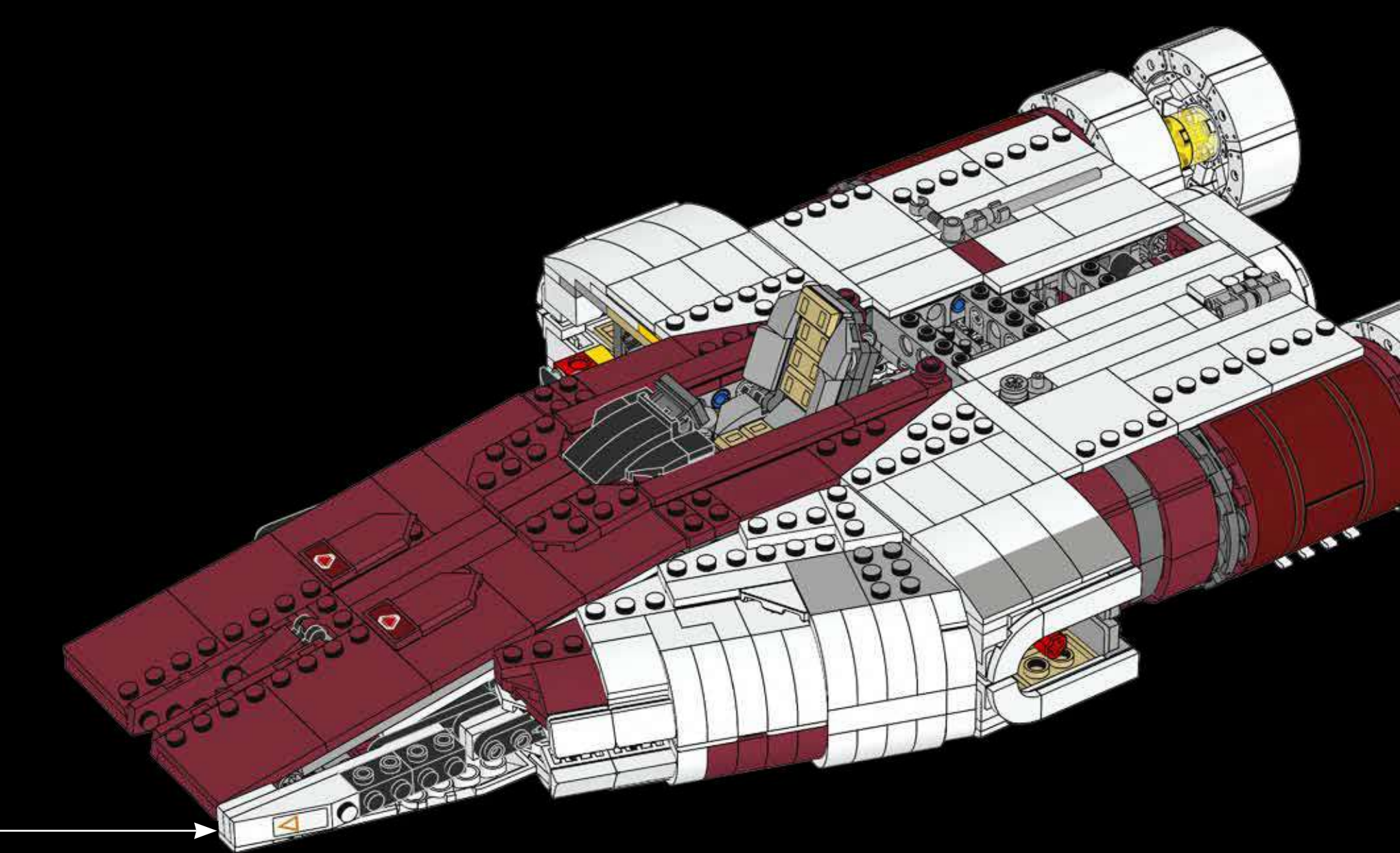

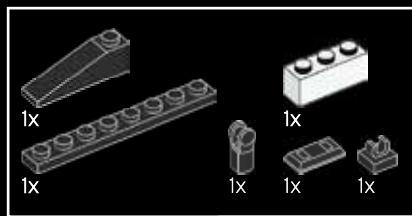

371

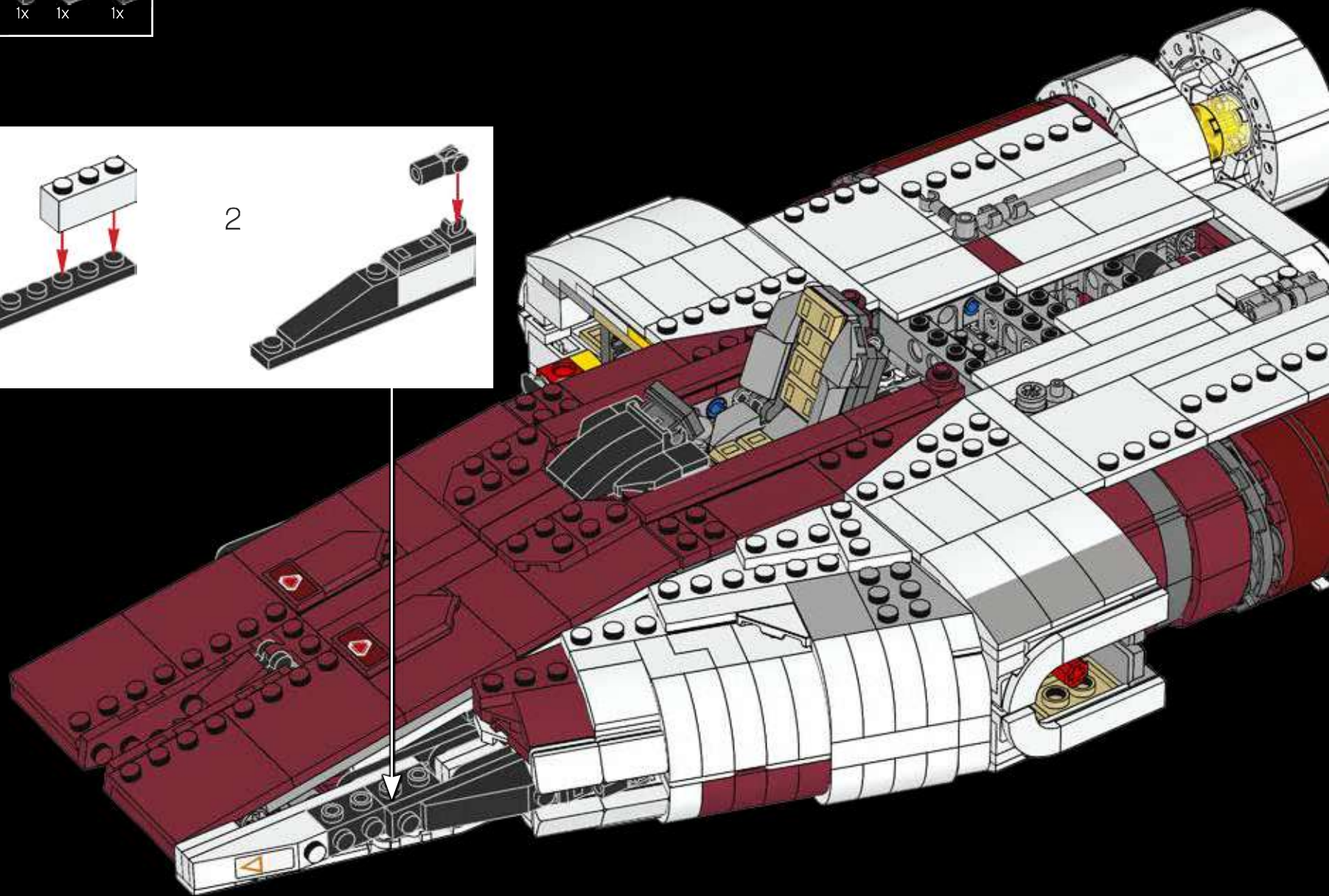
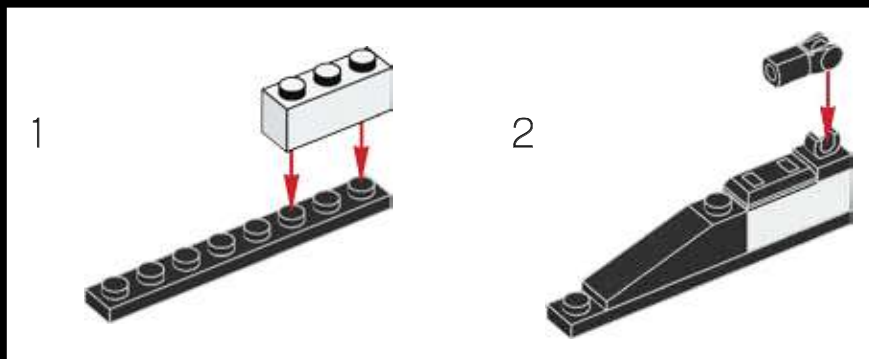

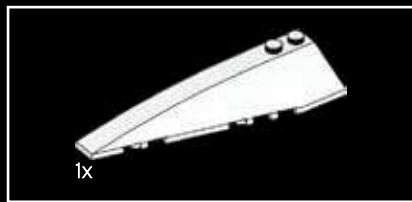

372

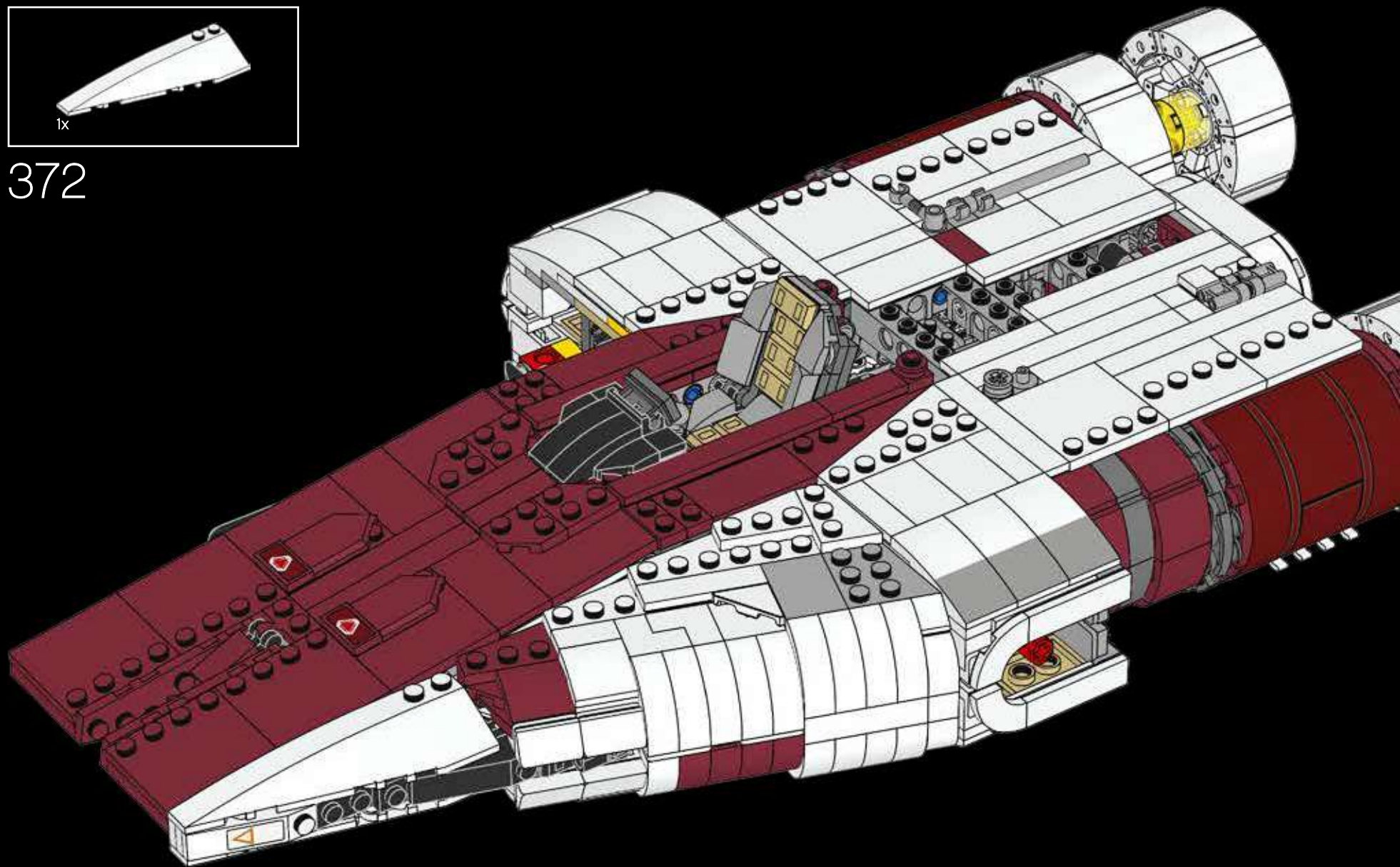

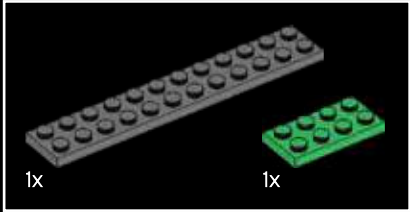
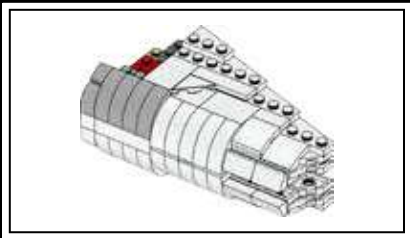

373

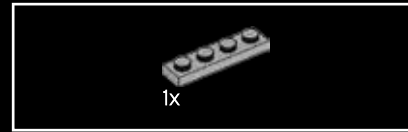
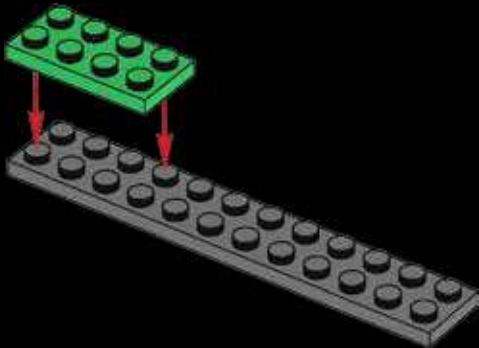

374

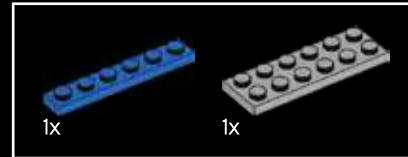
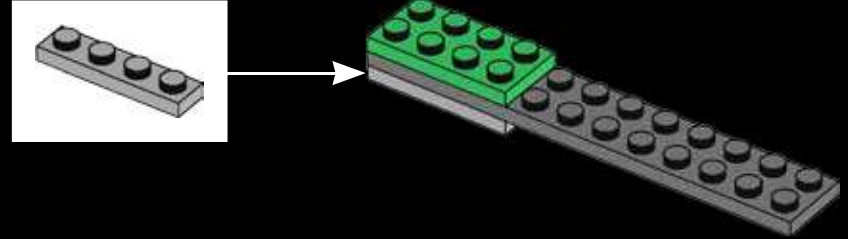

375

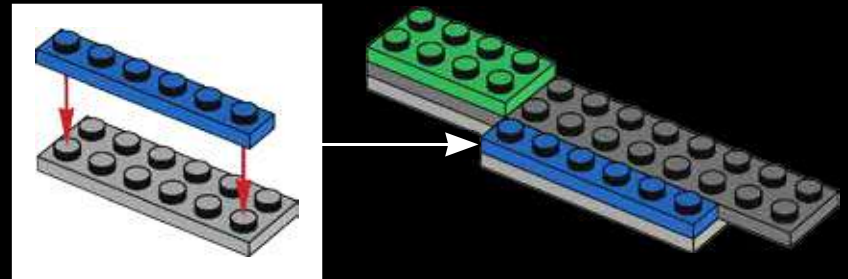





376

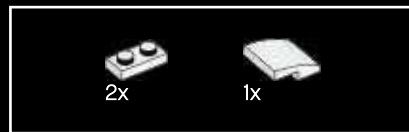
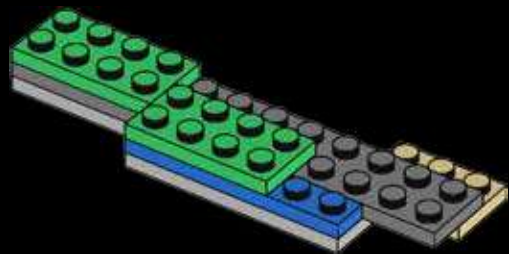

377

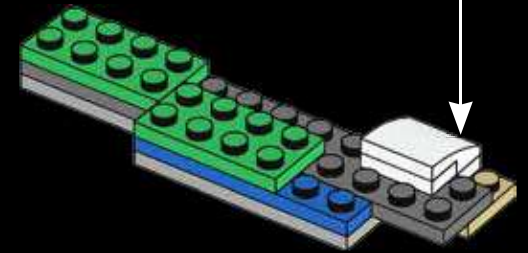
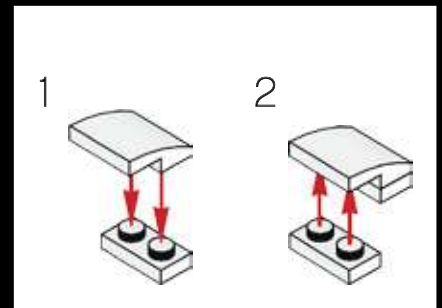

378

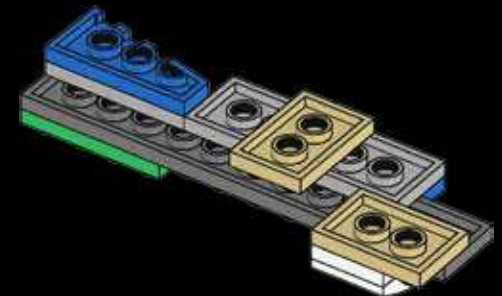

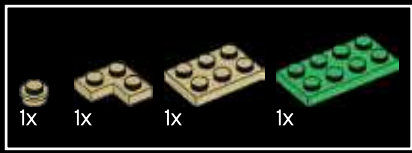

379

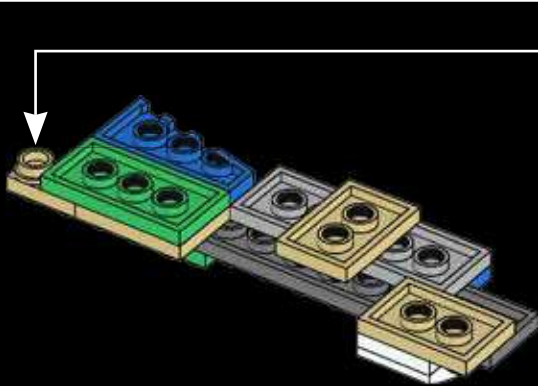
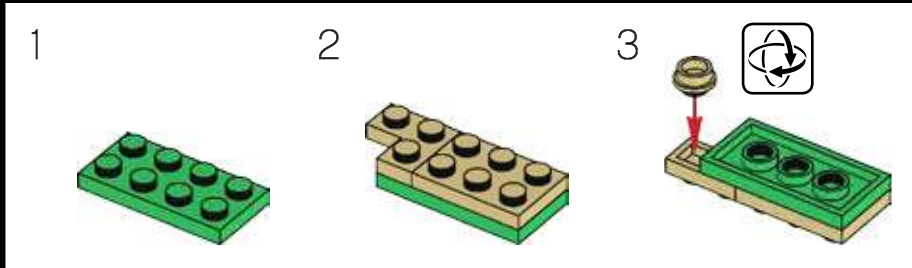

380

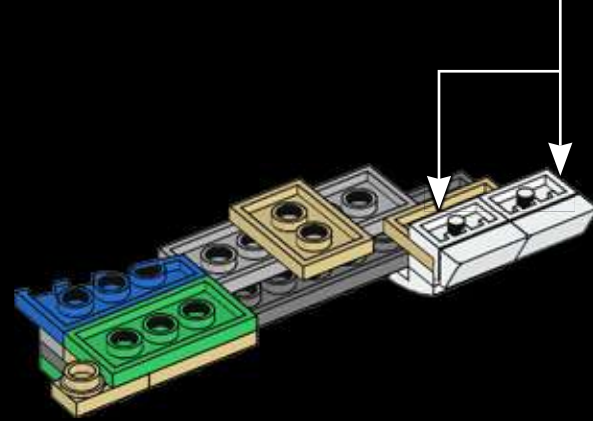
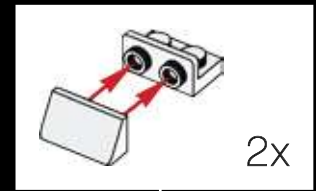

381

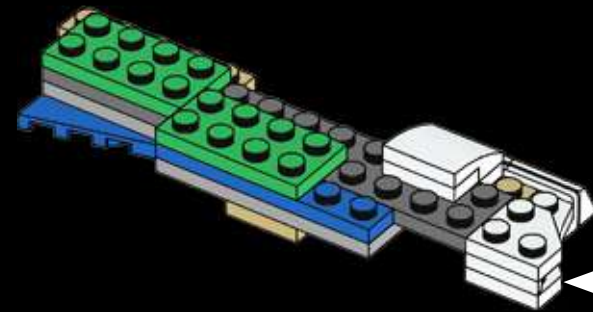
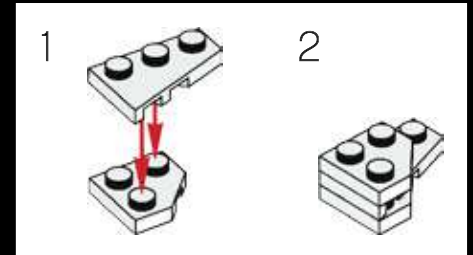

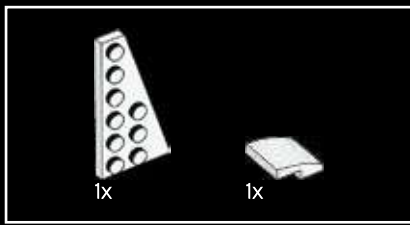

382

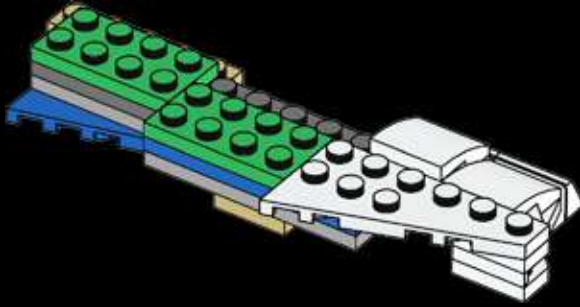

383

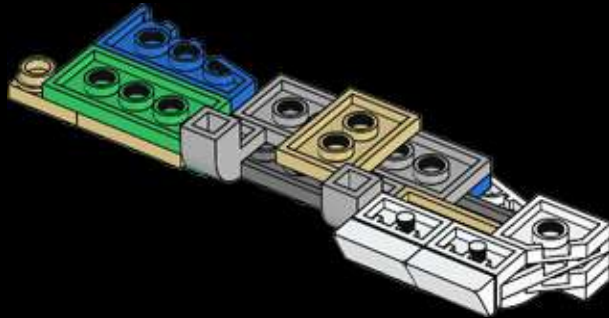

384

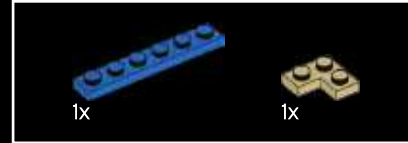
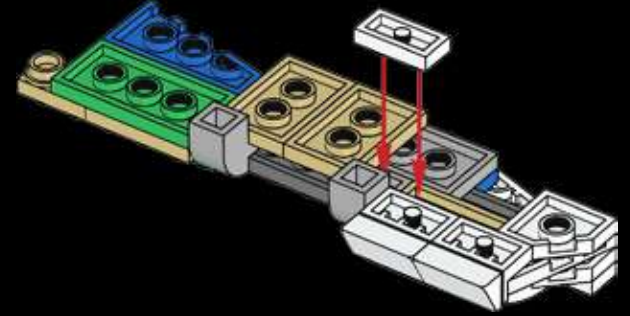

385

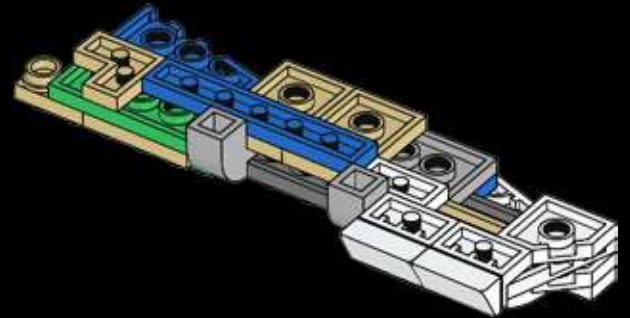



386

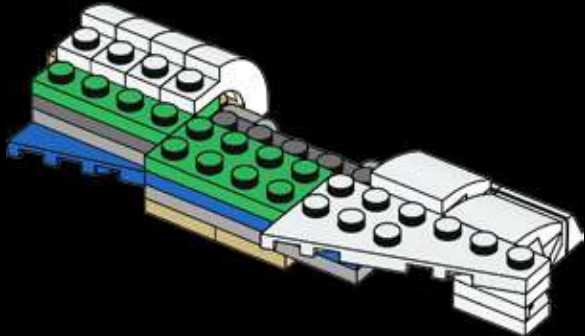

387

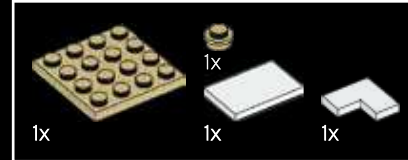
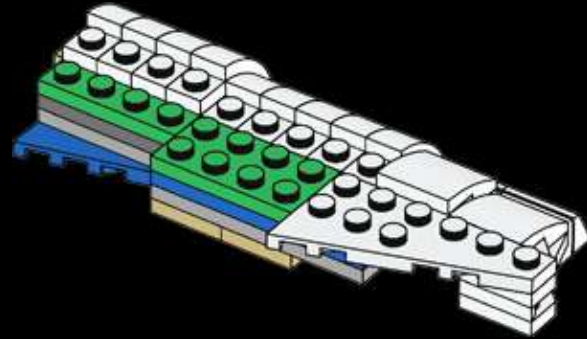

388

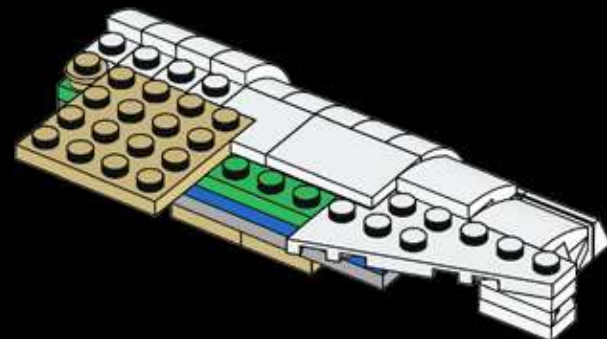

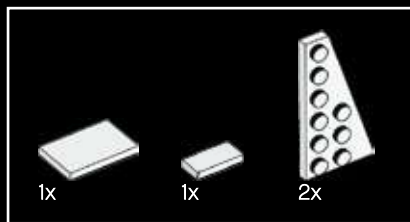

389

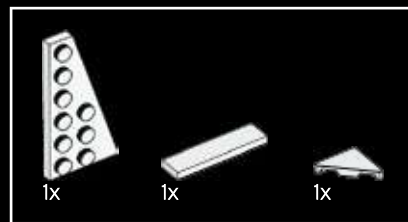
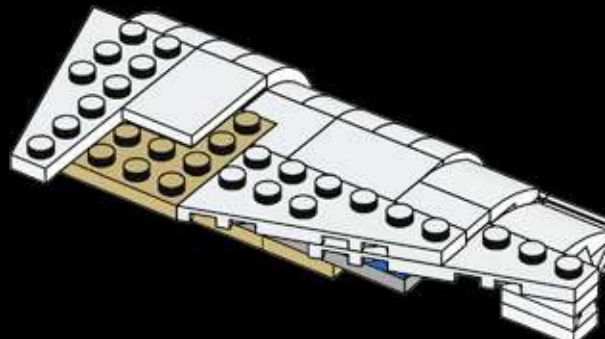

390

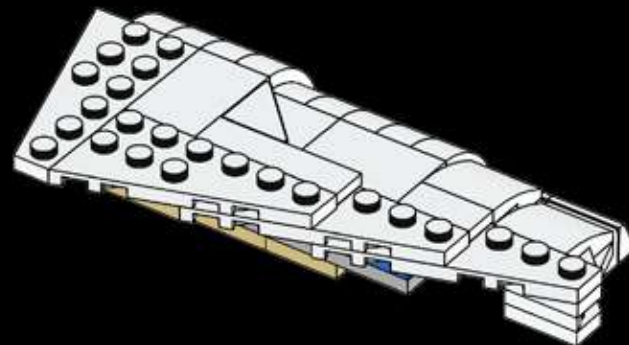

391

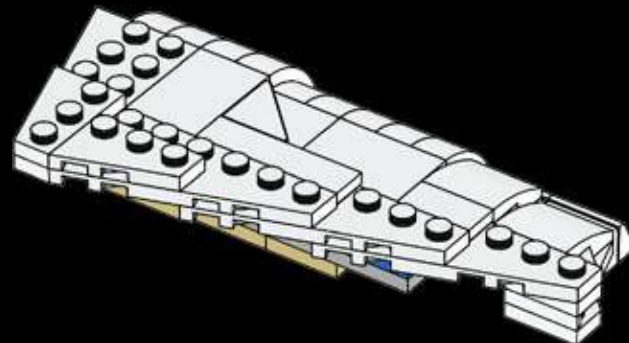



392

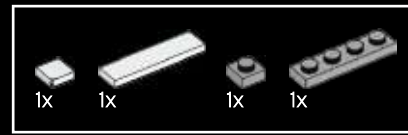
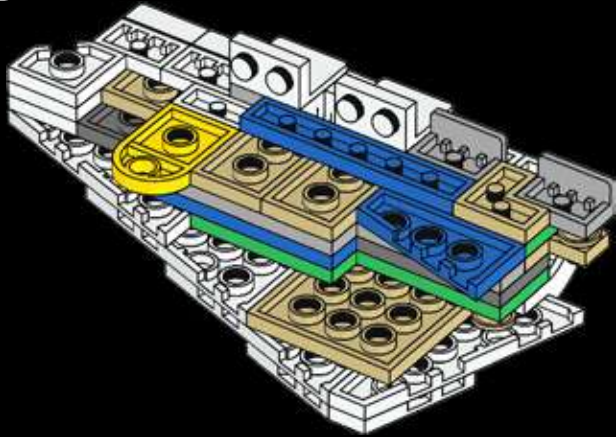

393

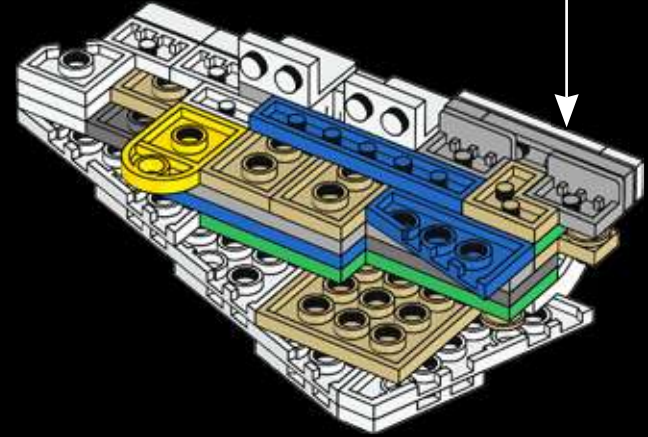
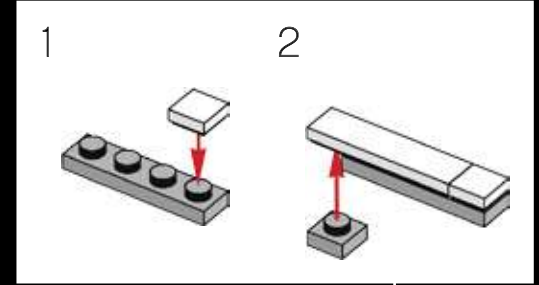



394

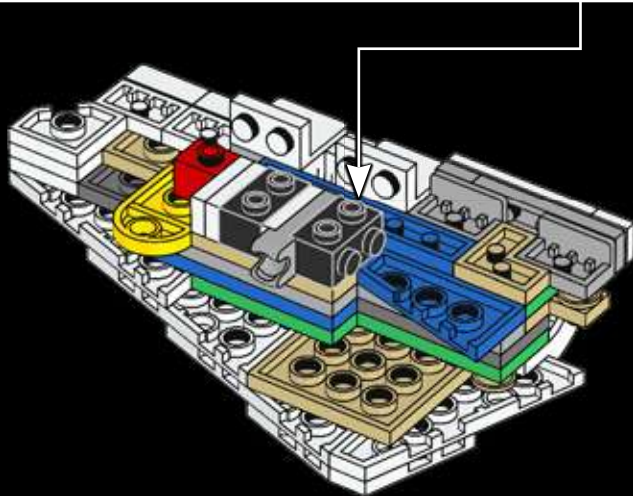
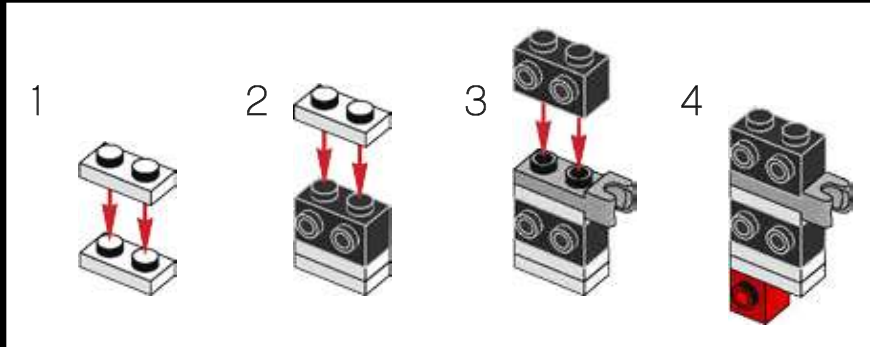

395

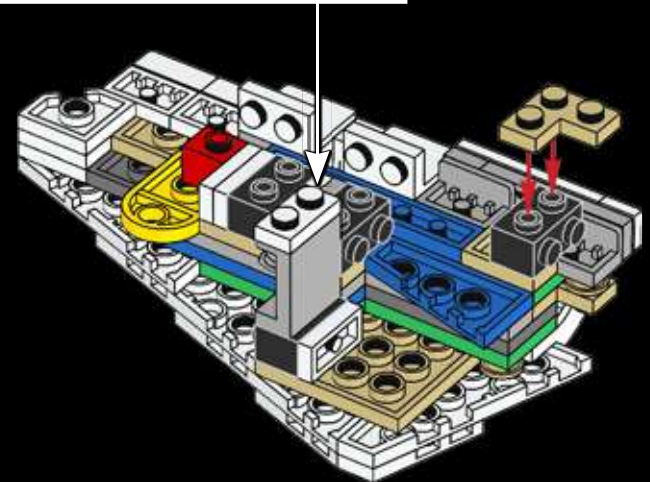
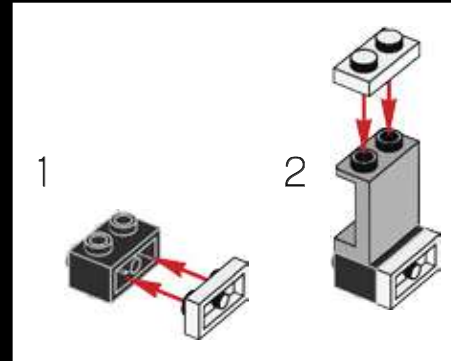

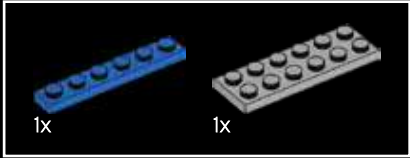
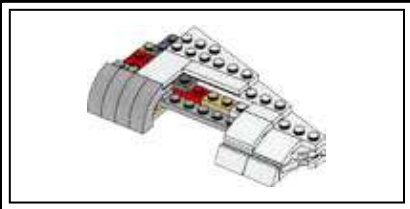

396

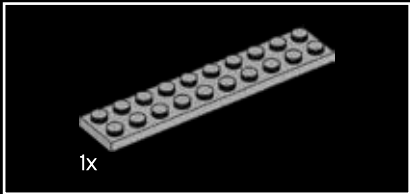
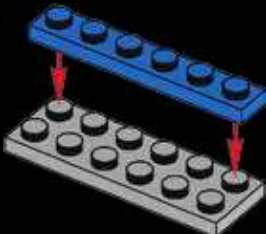

397

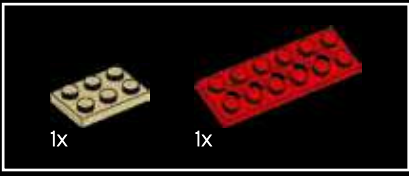
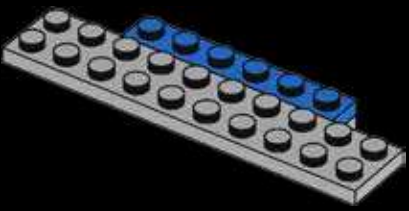

398

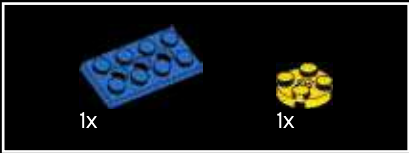
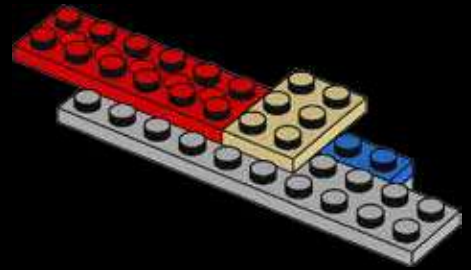

399

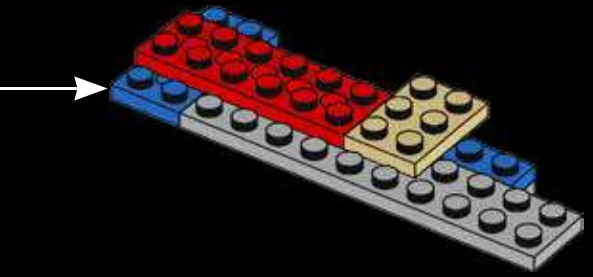
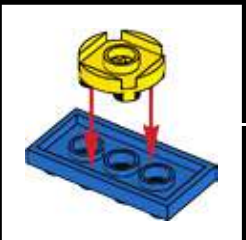





400

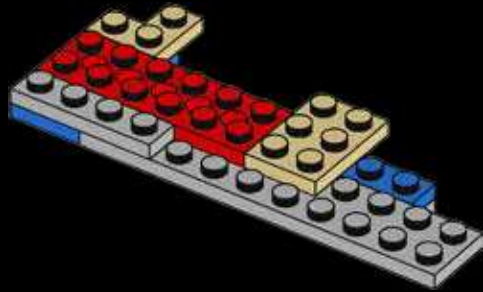

401

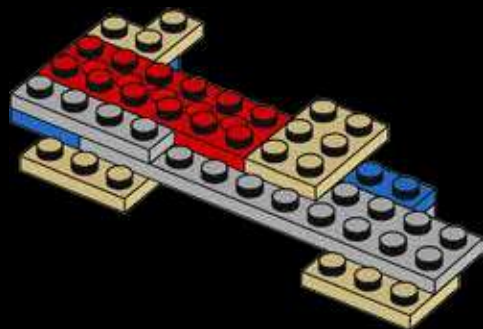

402

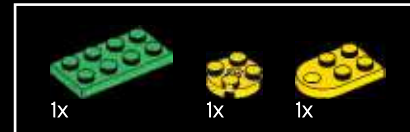
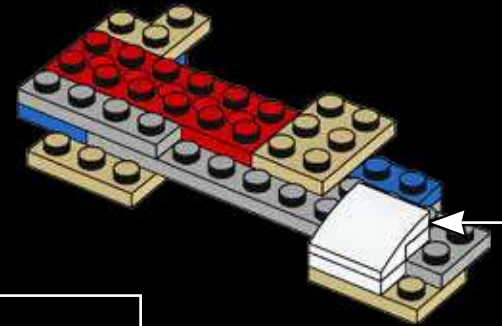
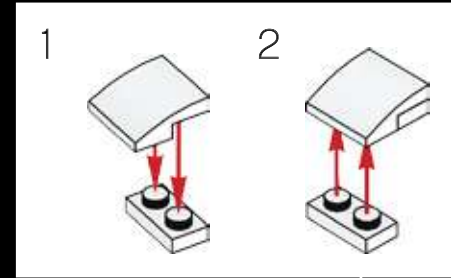

403

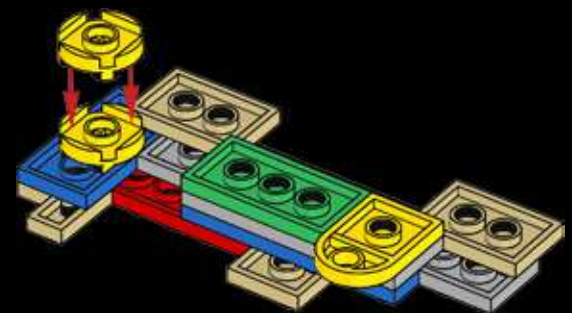

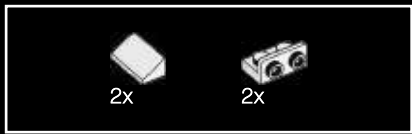

404

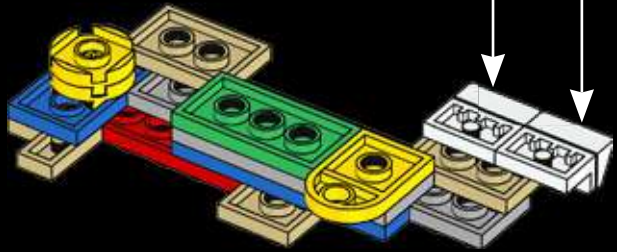
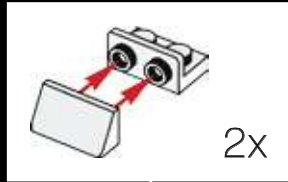

405

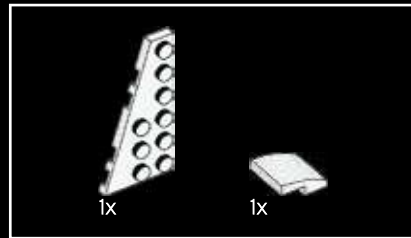
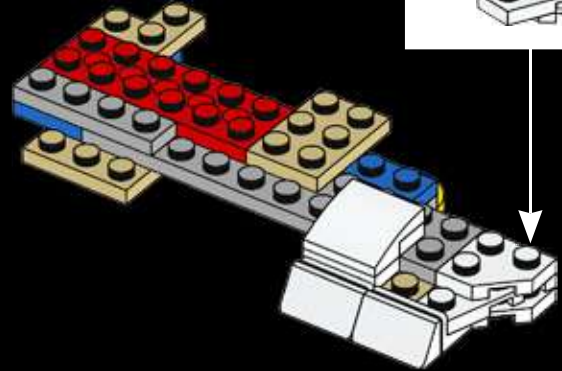
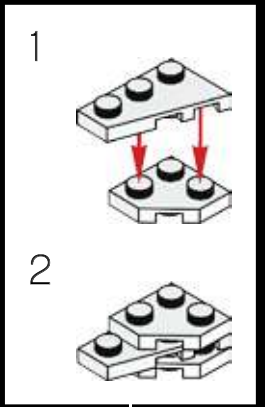

406

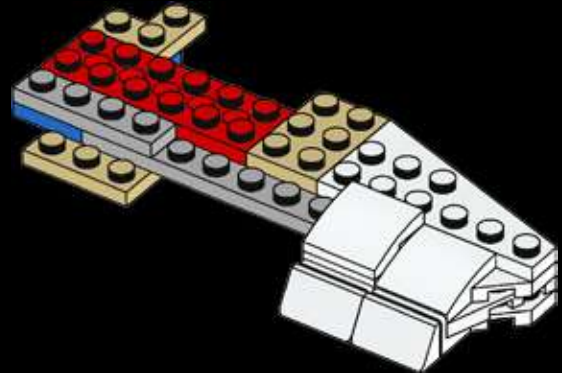

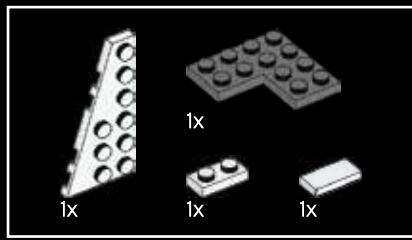

407

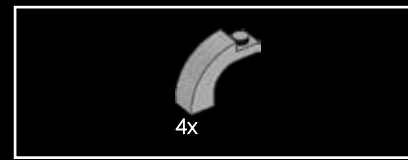
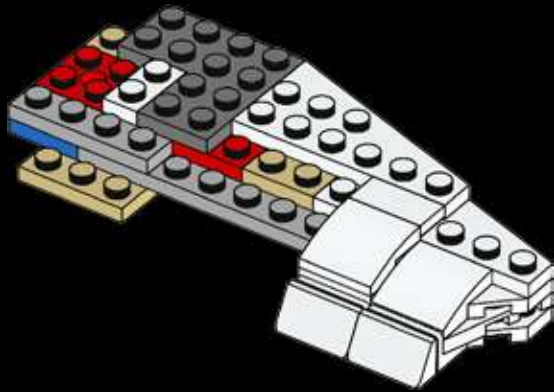

408

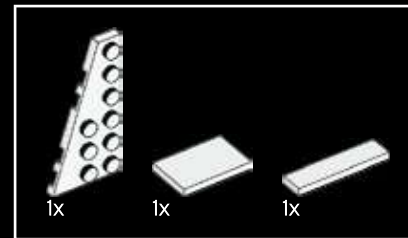
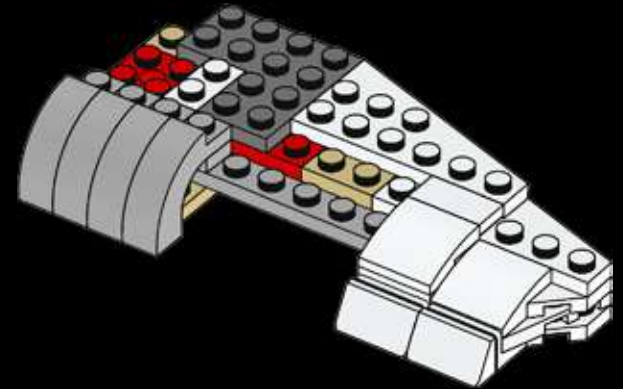

409

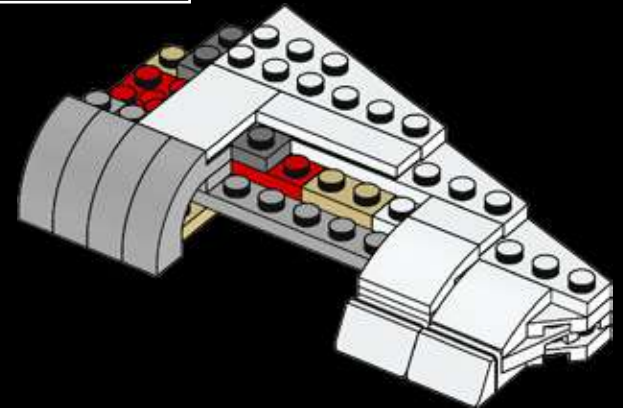



410

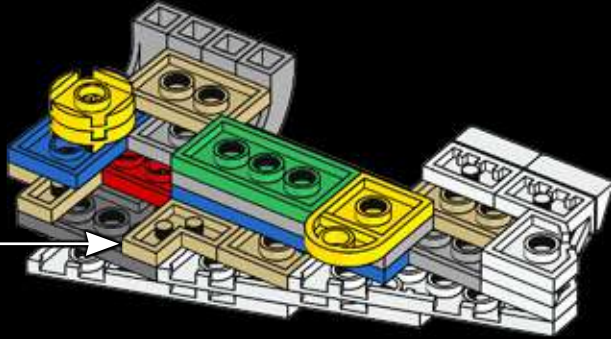

411

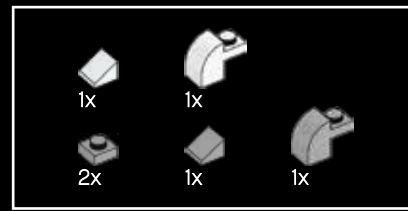
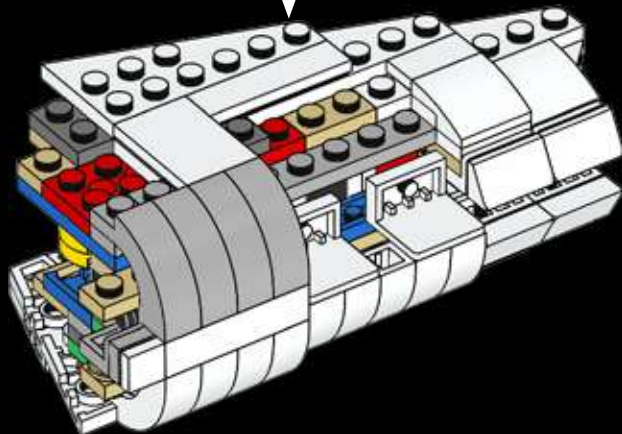

412

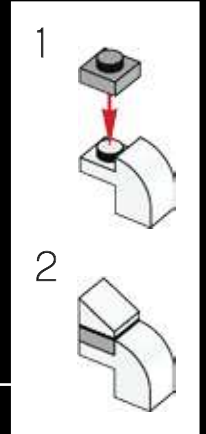
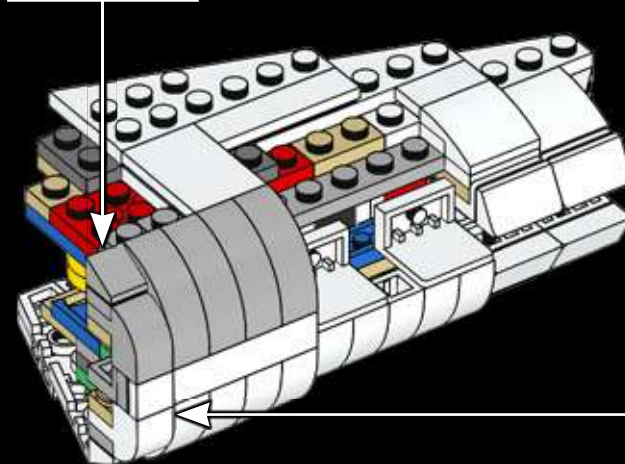
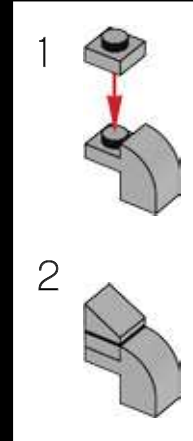



413

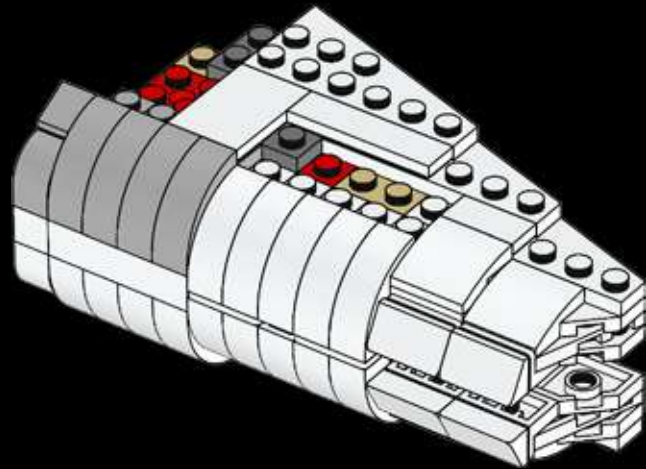

414

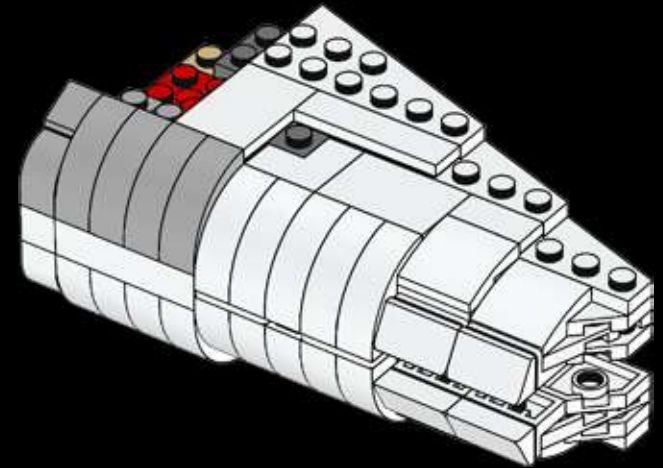

415

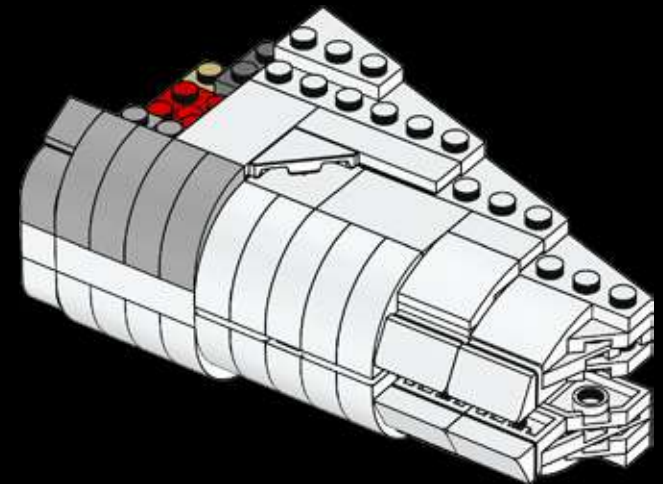

416

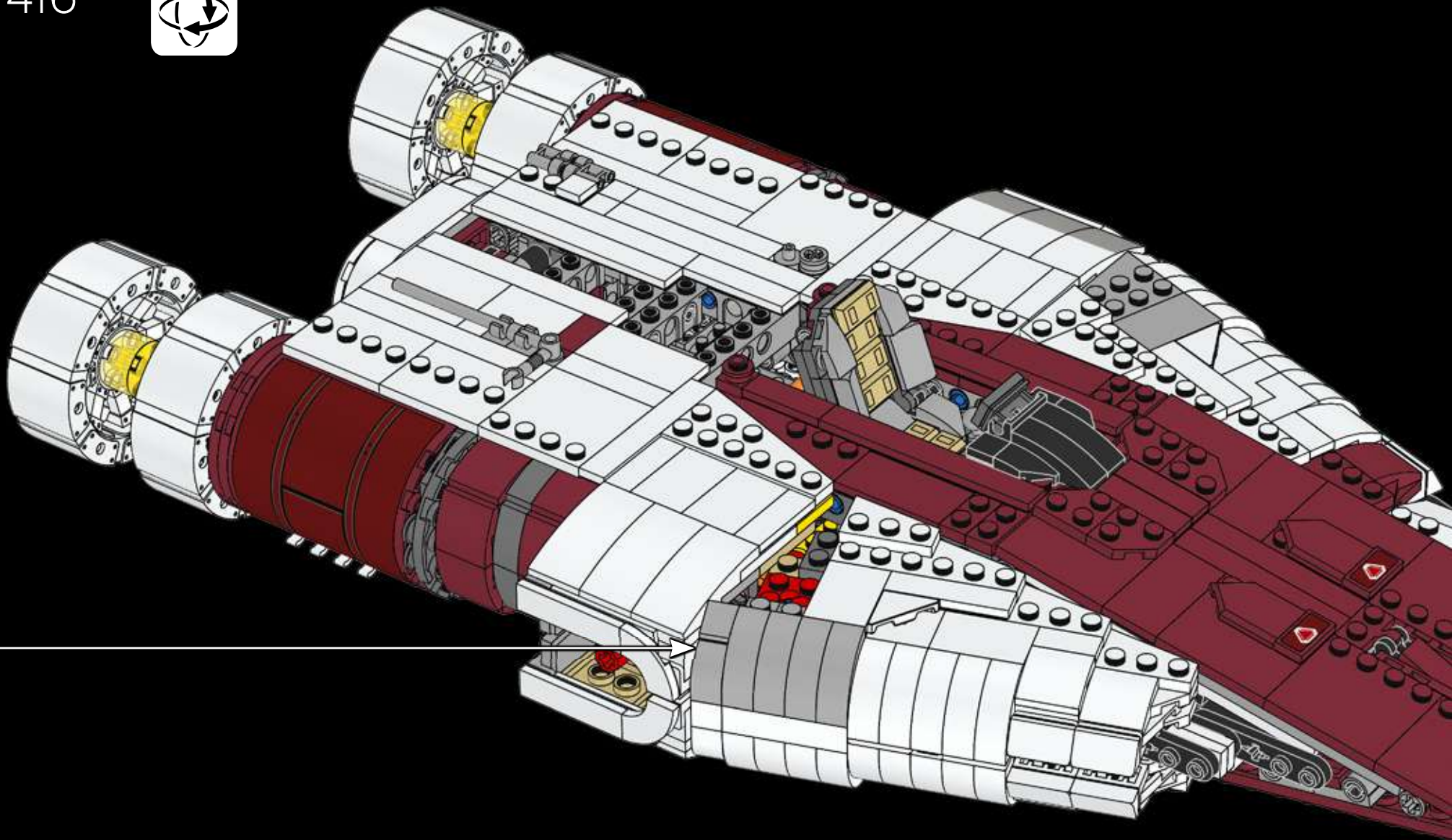

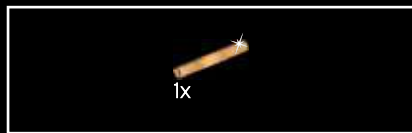

417

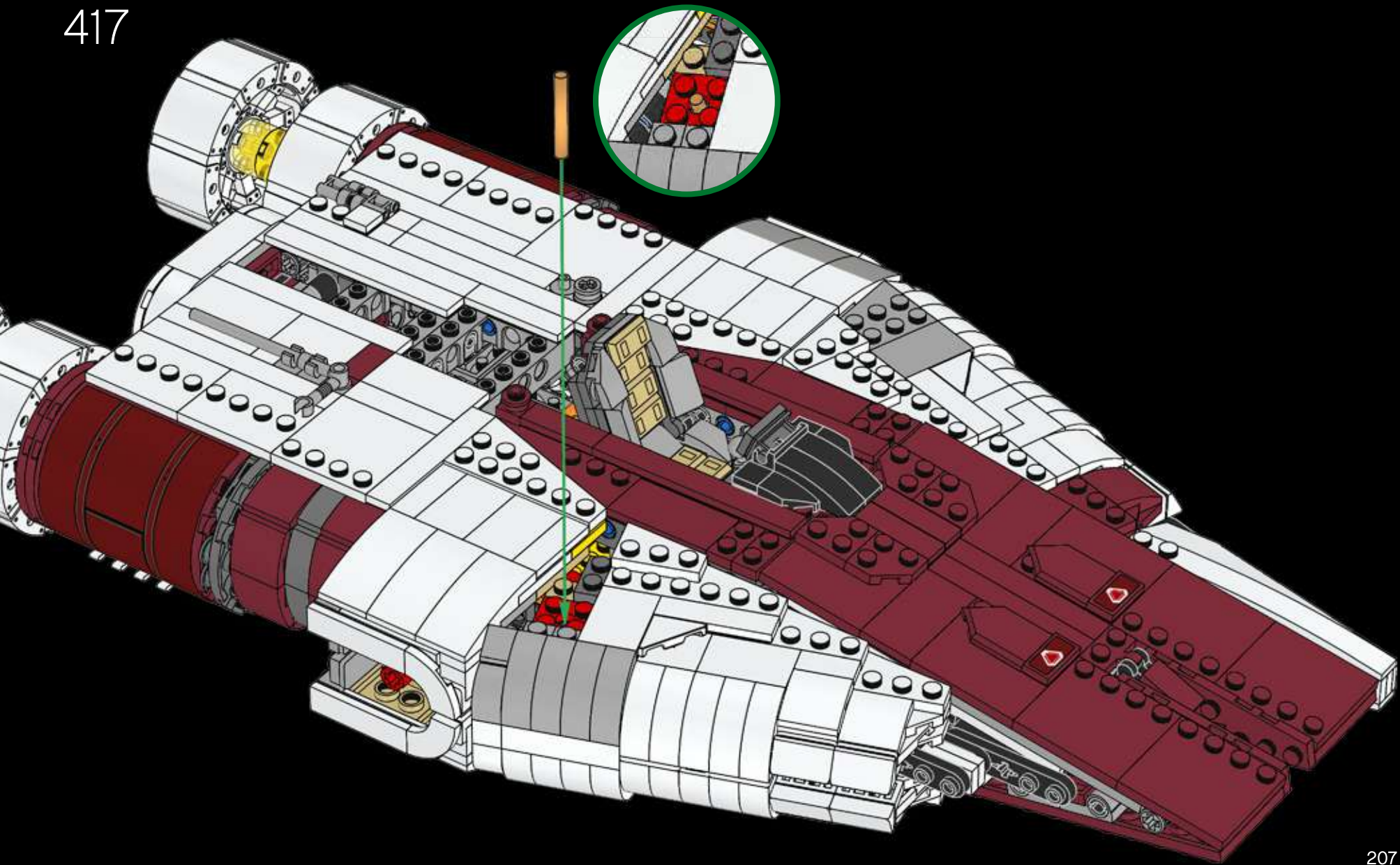

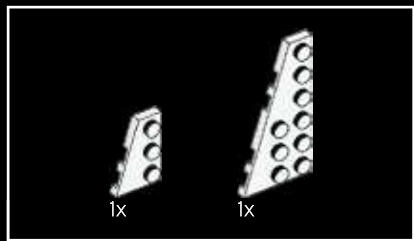

418

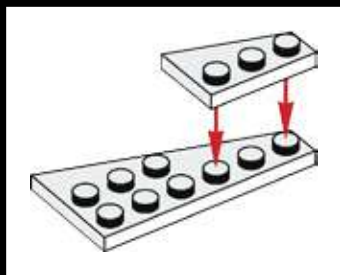
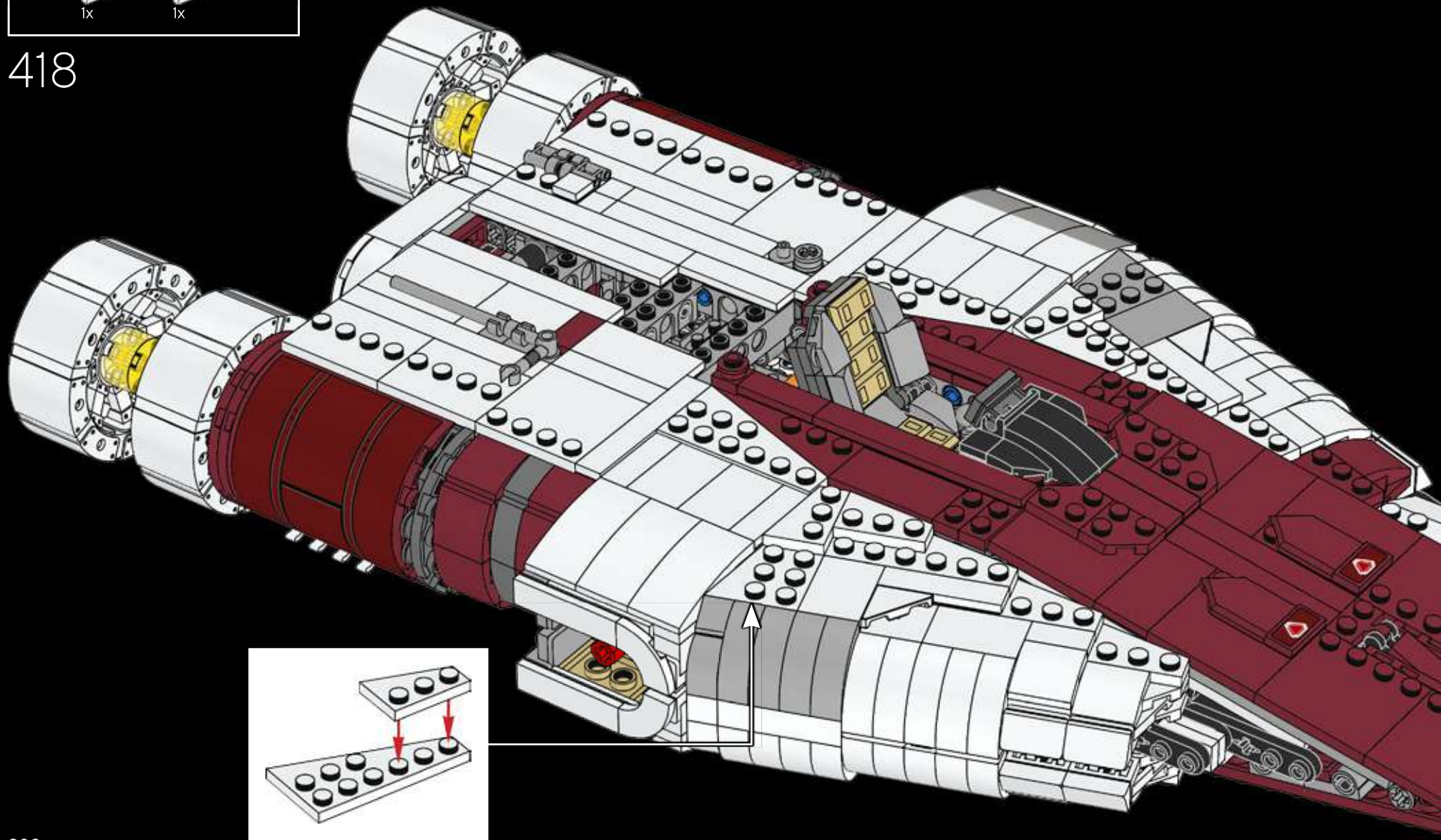



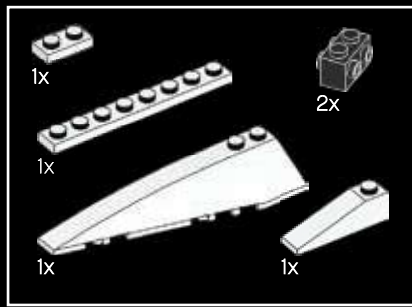

419

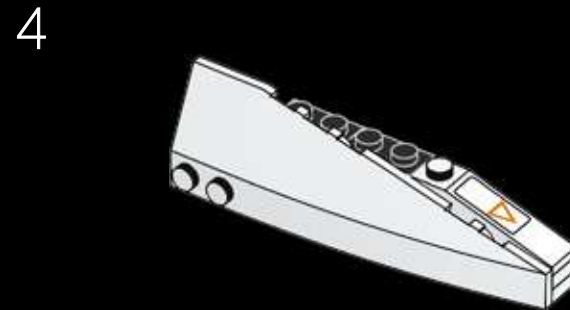
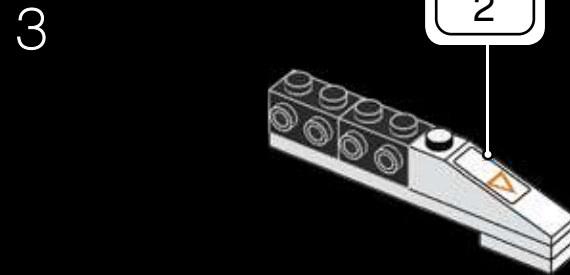
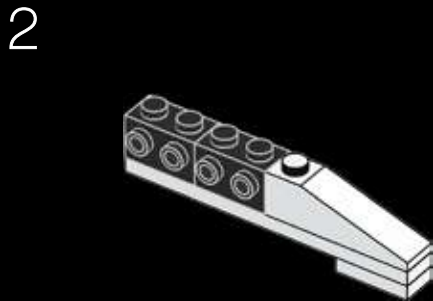
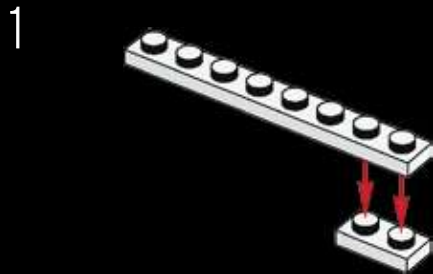

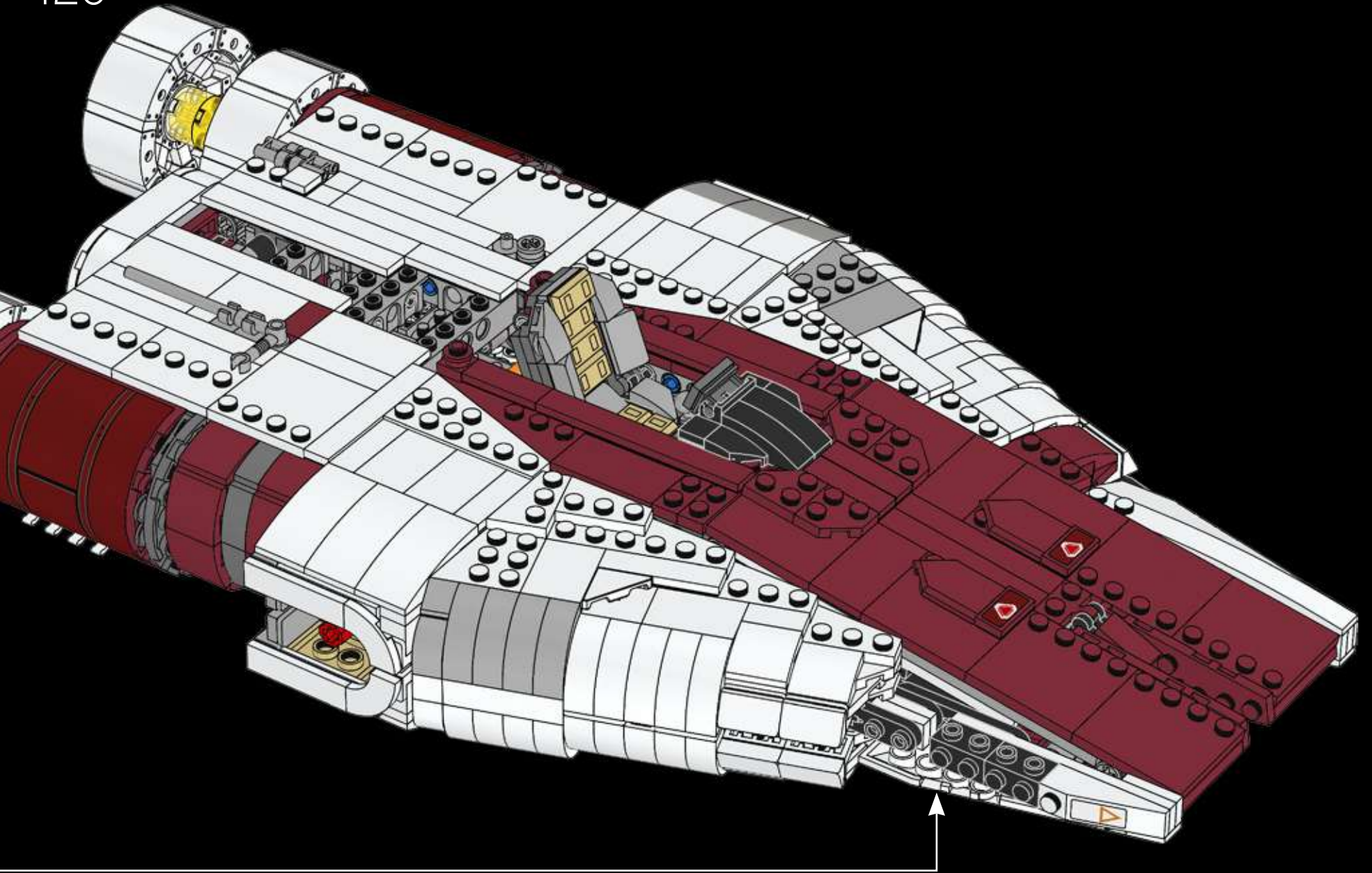

421

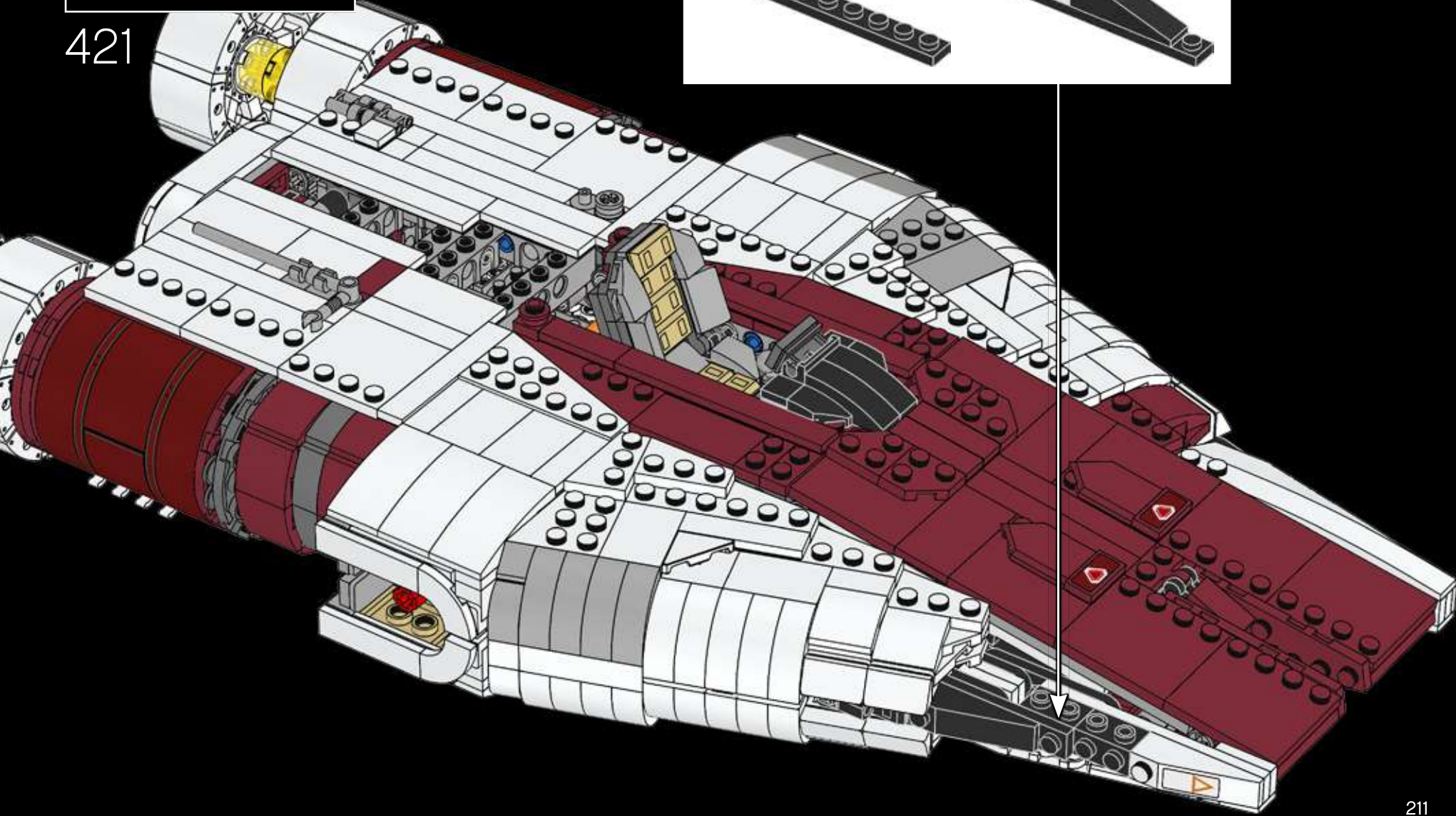
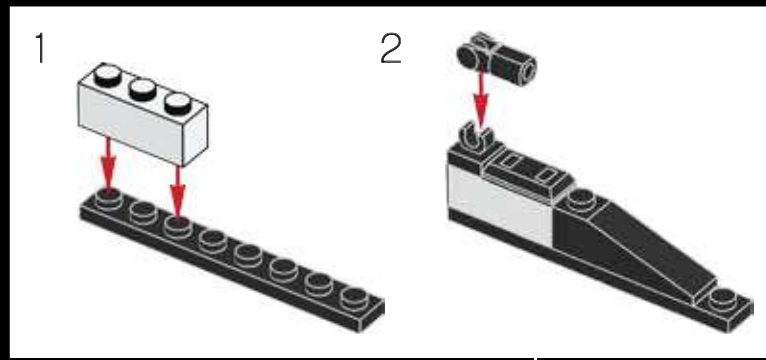
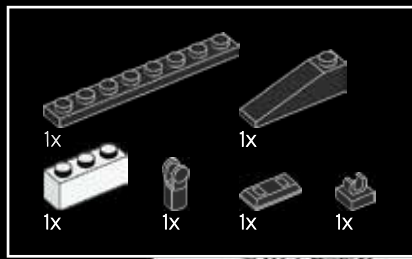

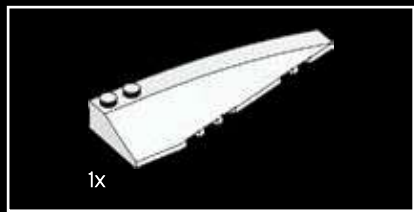

422

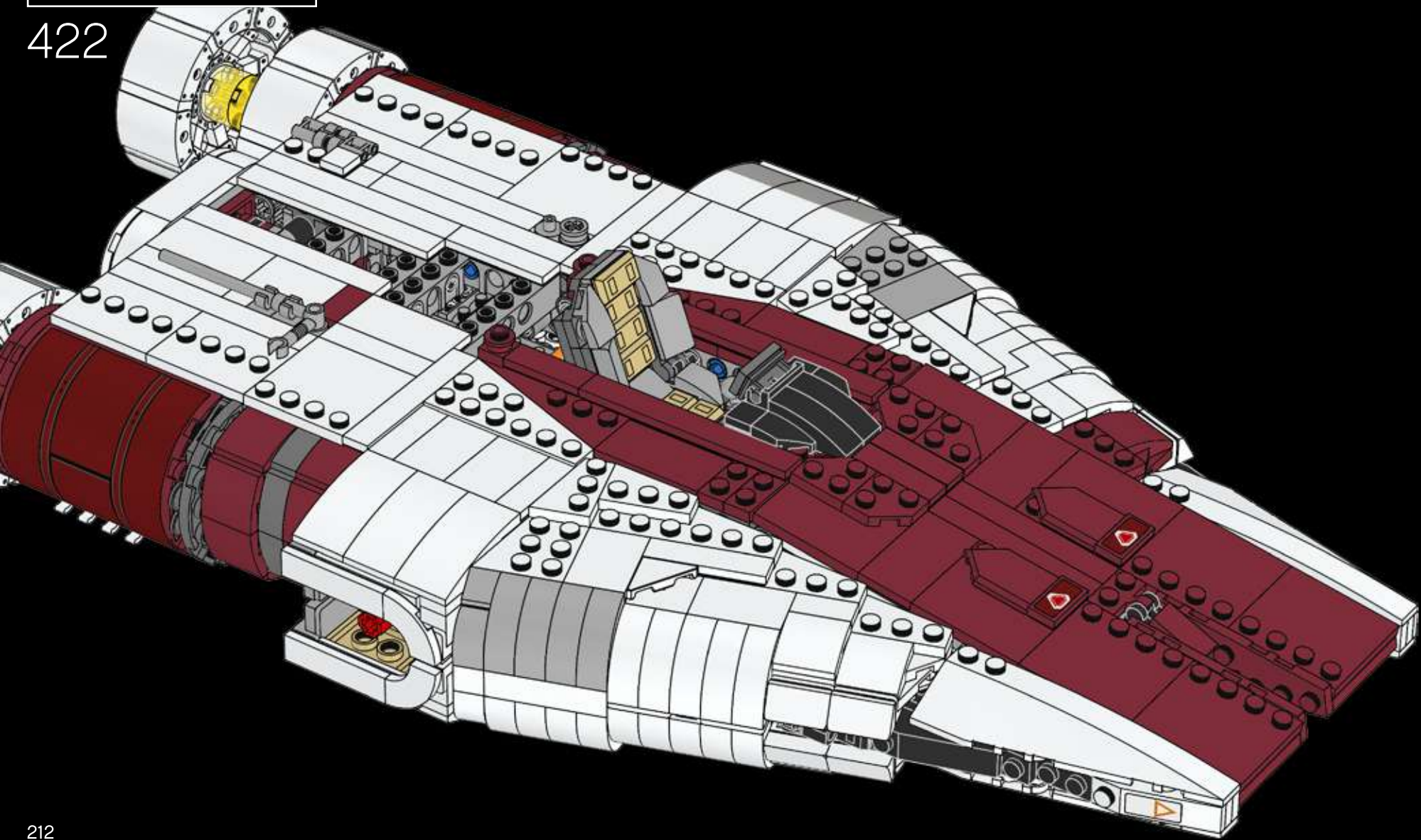

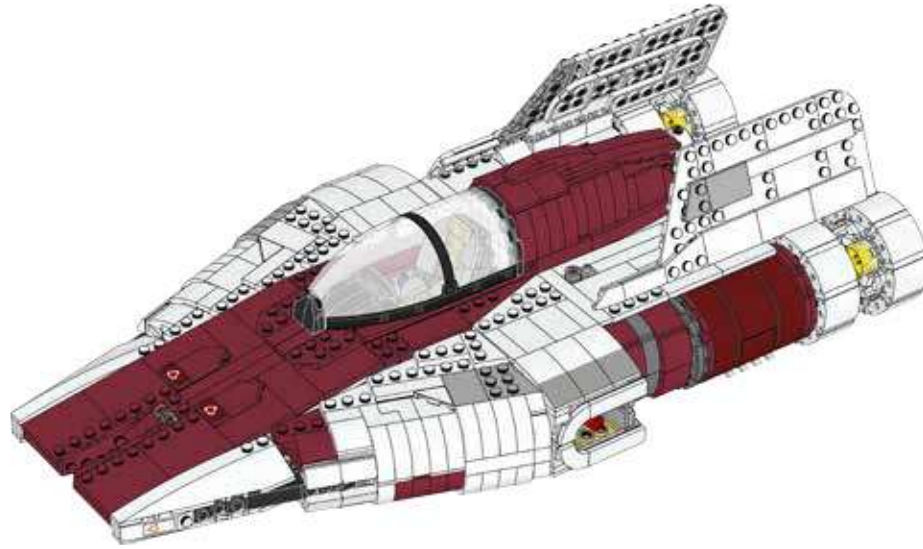
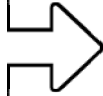

423



424





2x

425

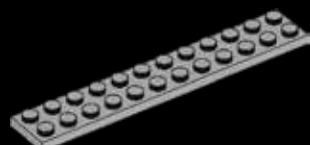

1x

426

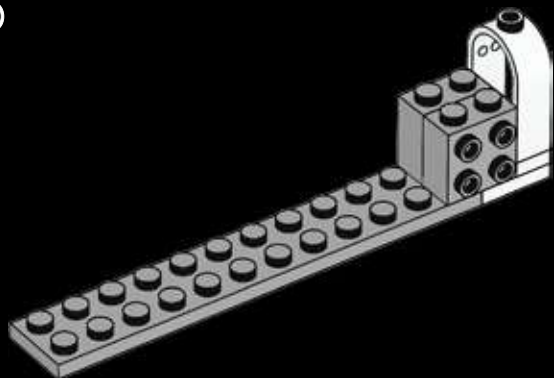

6x

427

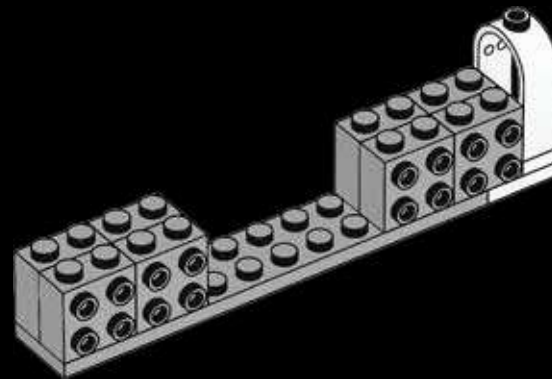

1x



1x

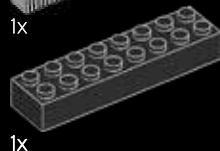

1x



1x

428

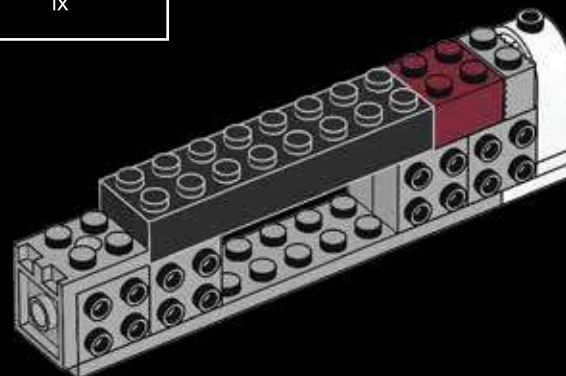

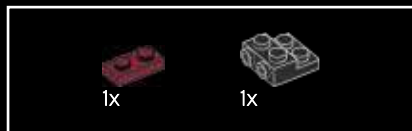

429

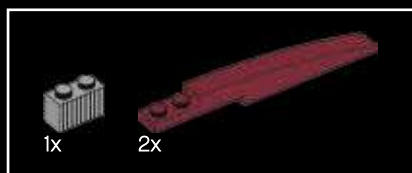
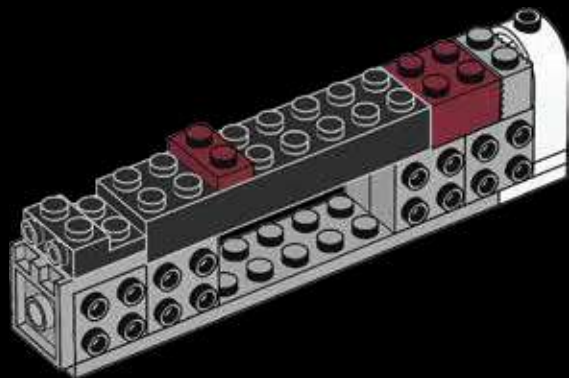

430

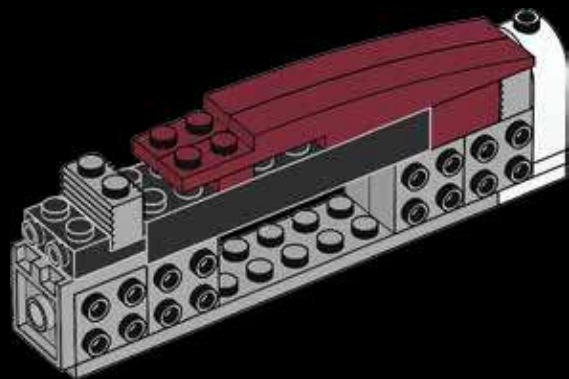



431



432

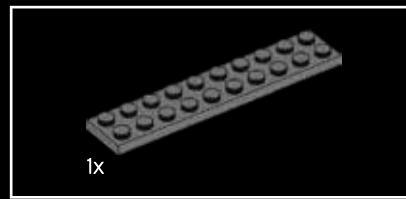

433

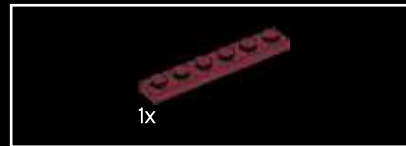
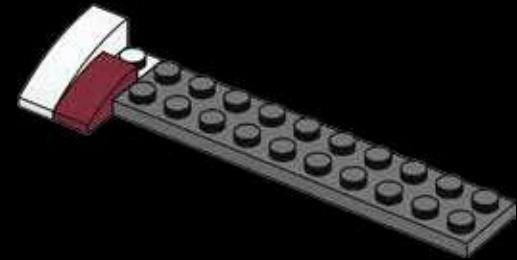

434

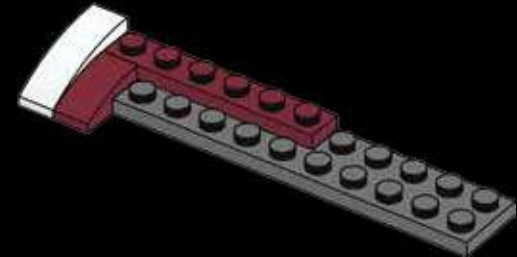



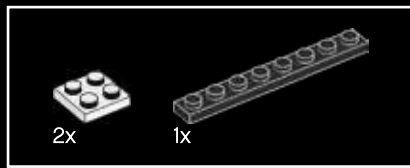

435

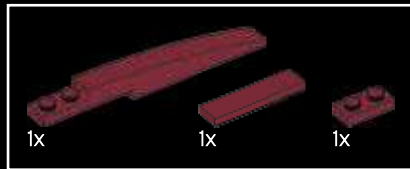
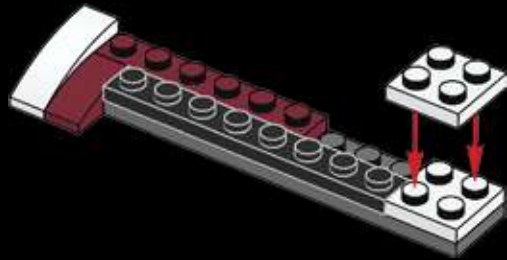

436

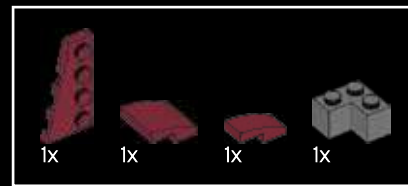
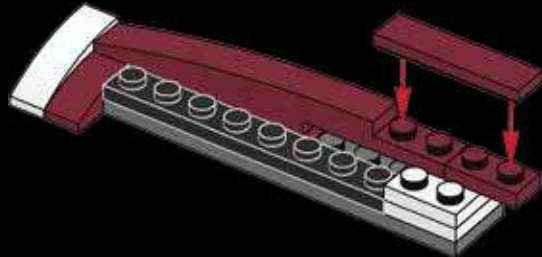

437

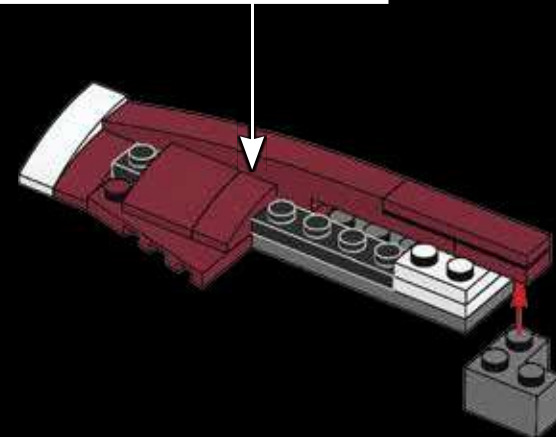
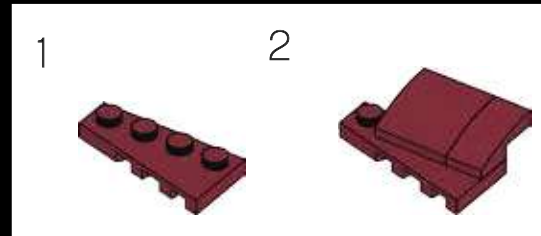

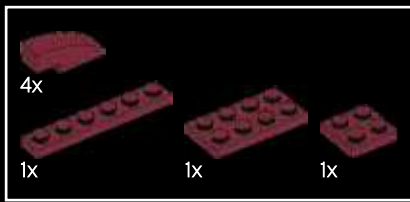

438

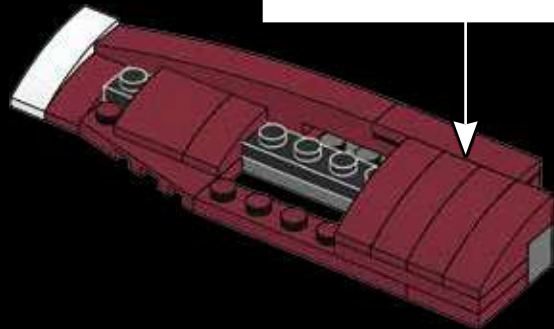
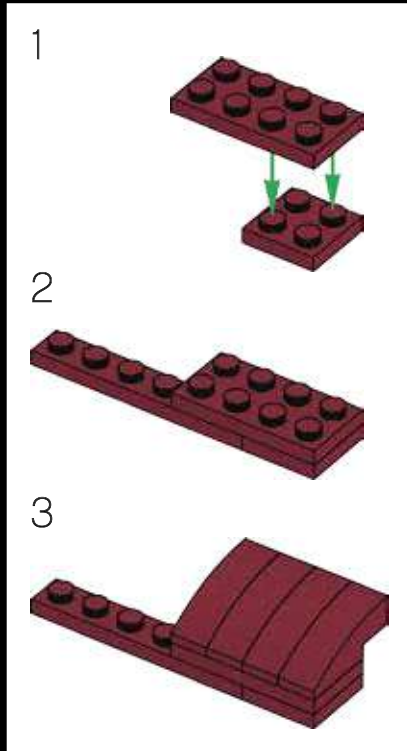

439

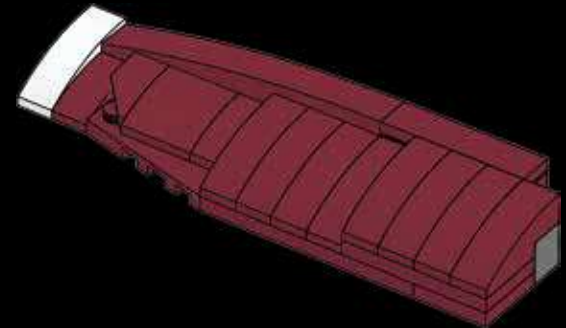

440

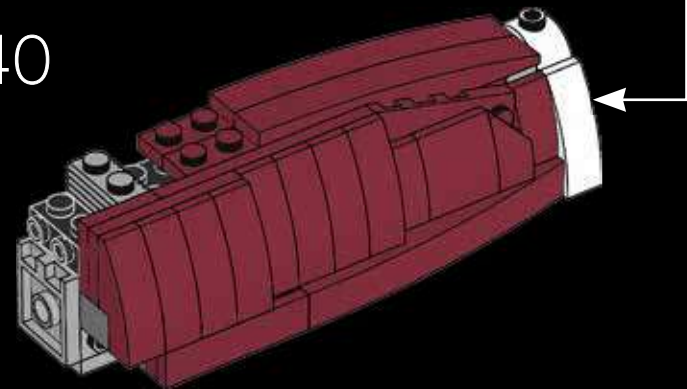



441

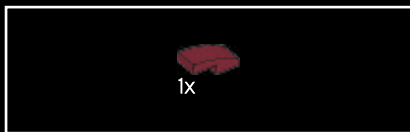

442

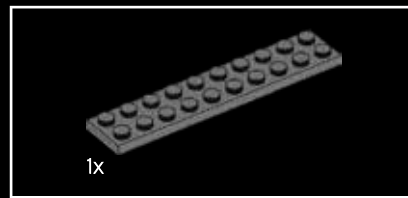

443

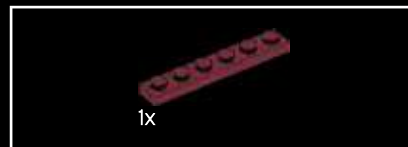

444

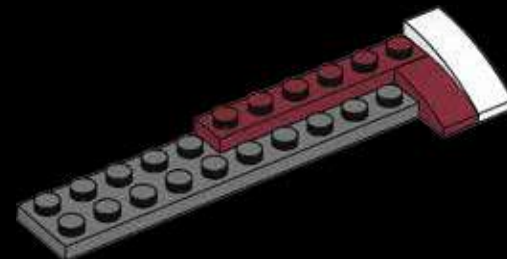

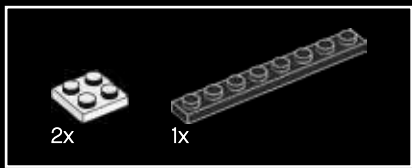

445

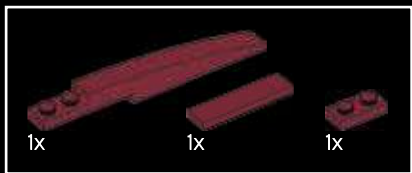
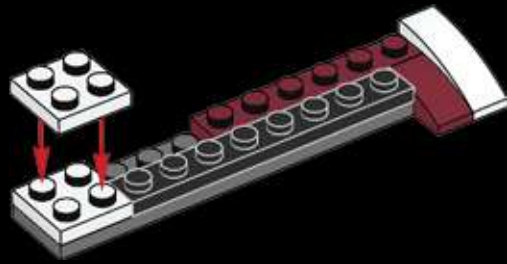

446

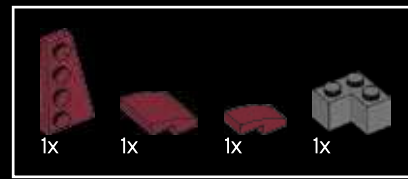
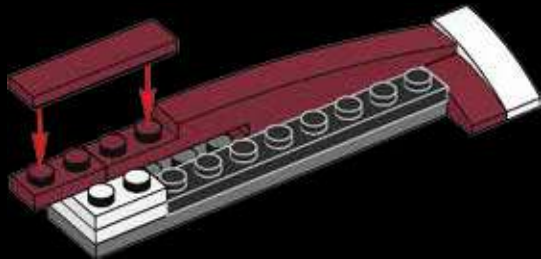

447

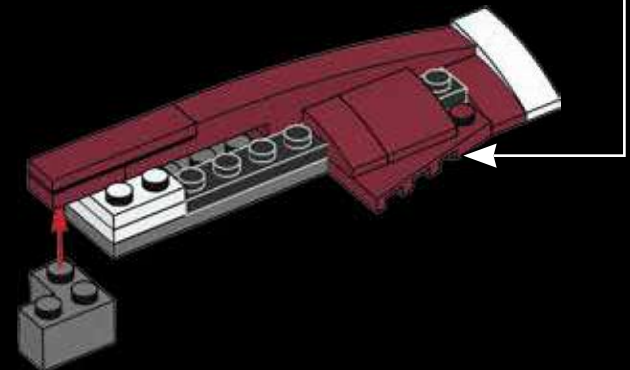
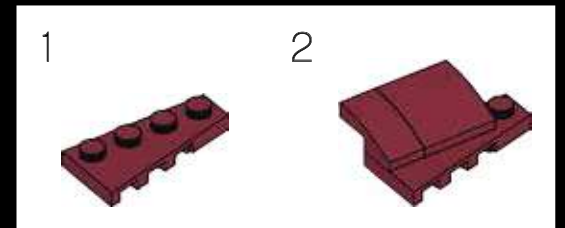

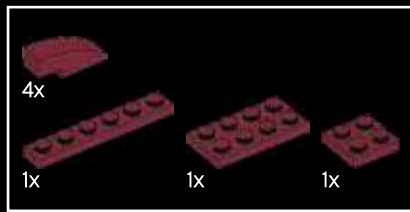

448

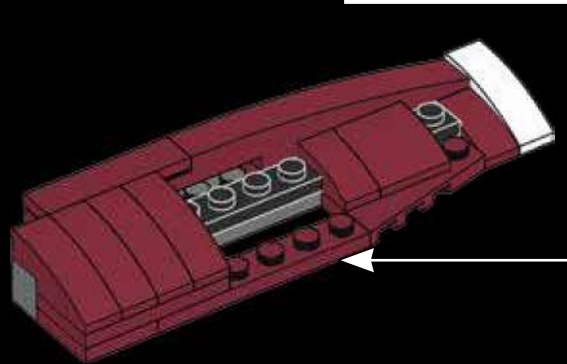
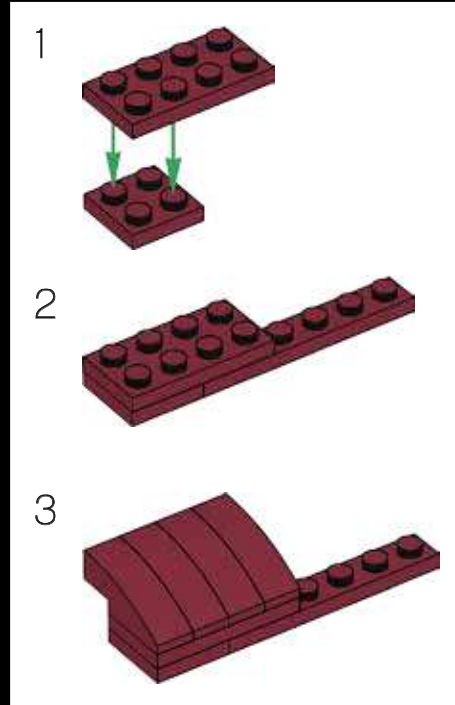

449

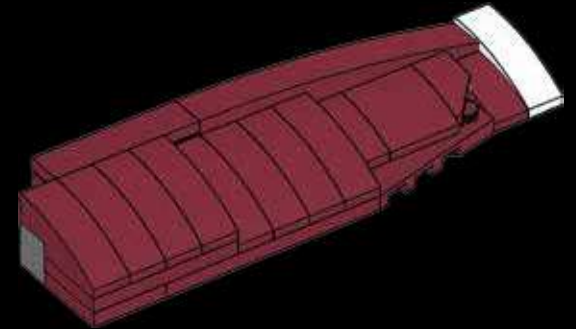

450

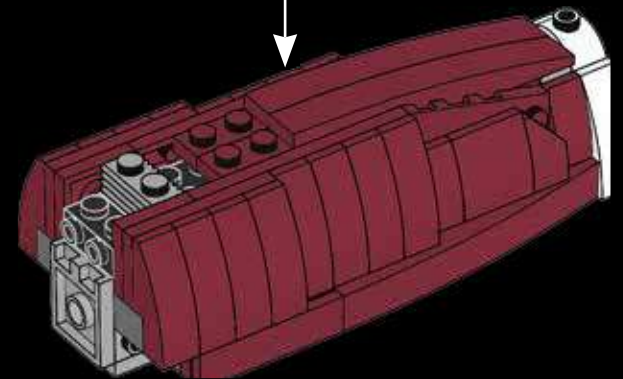

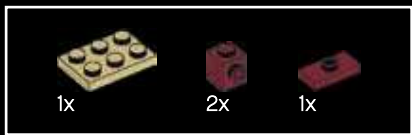

451

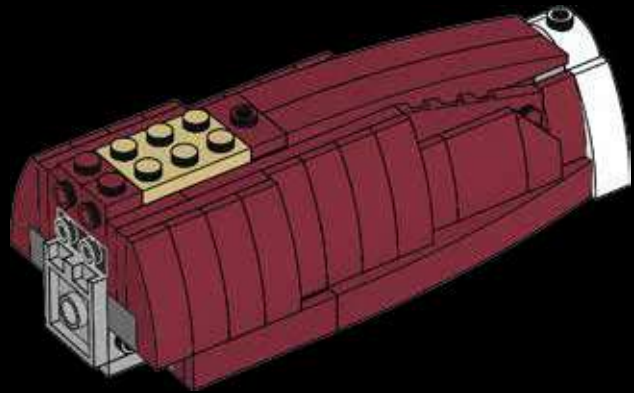

452

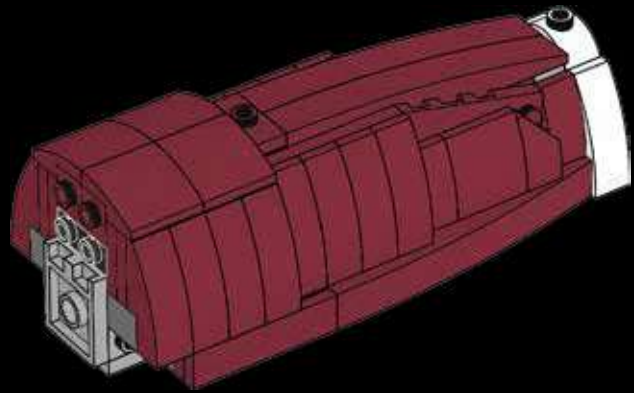

453

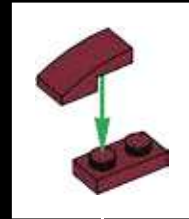

1

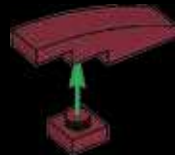

2

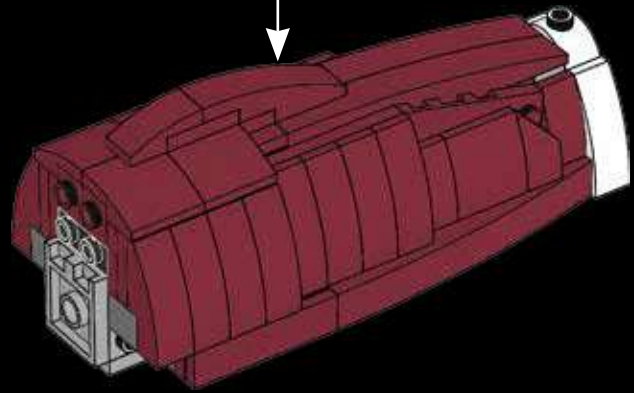
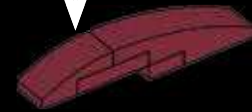

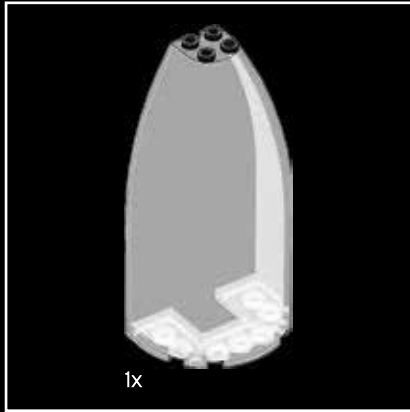

454

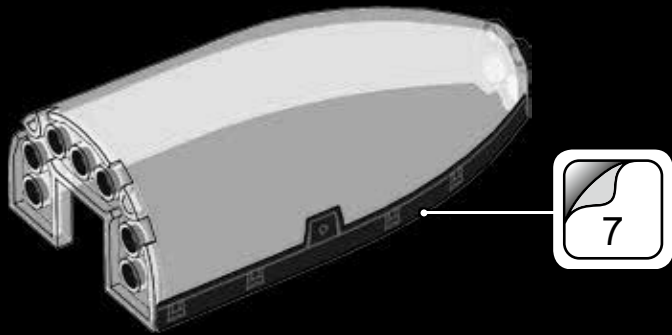

455

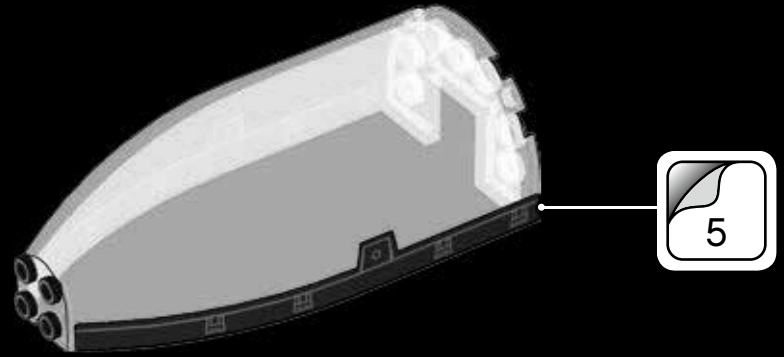

456

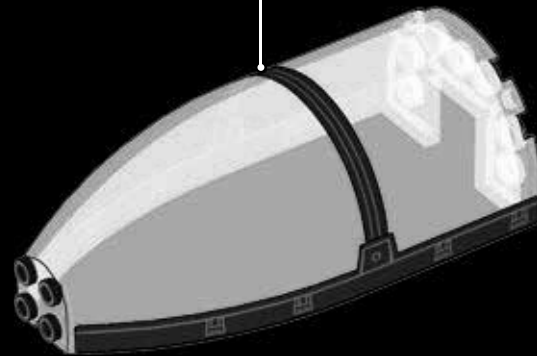

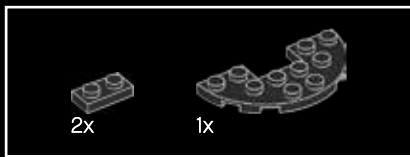

457

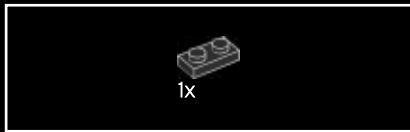
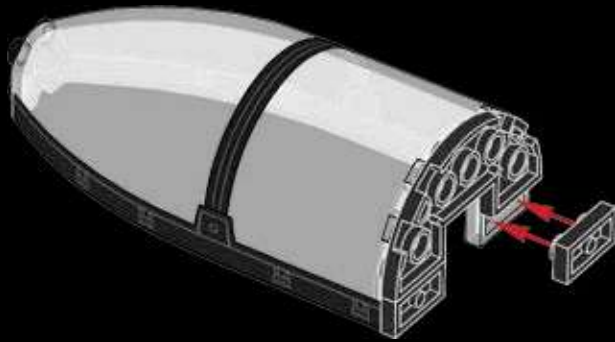

458

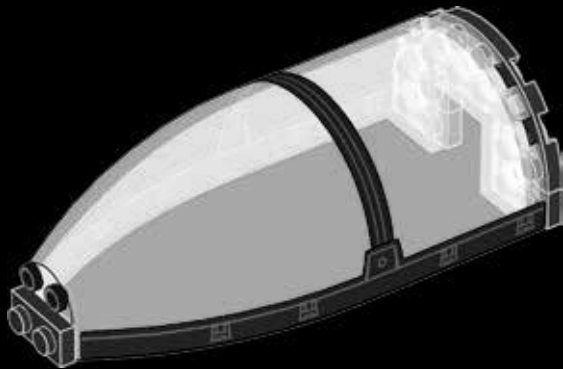

459

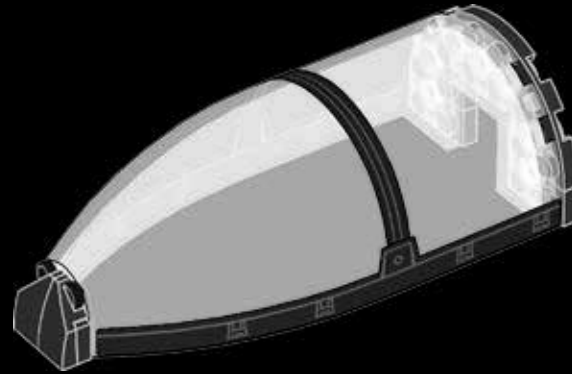

460

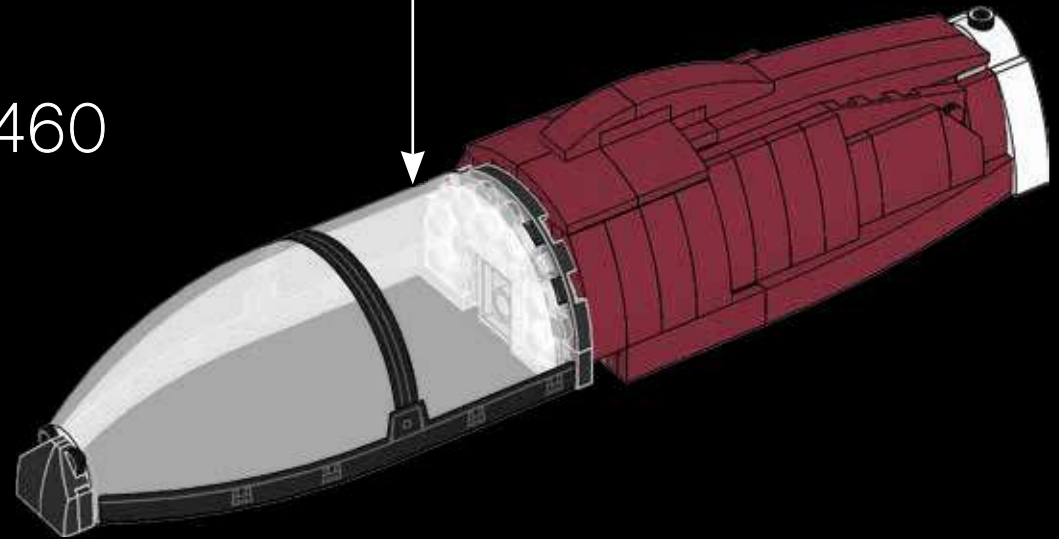



461

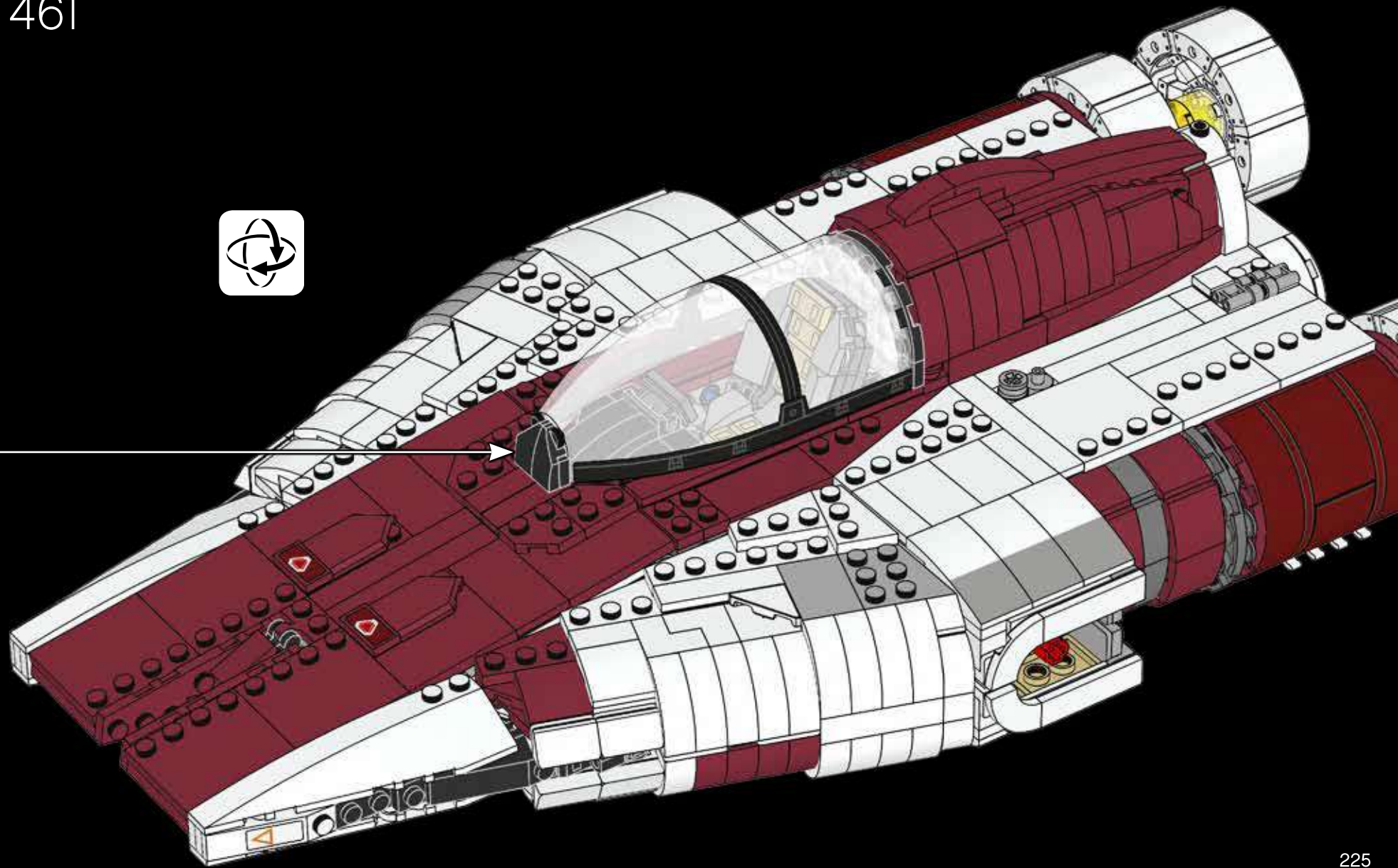



2x

462



2x

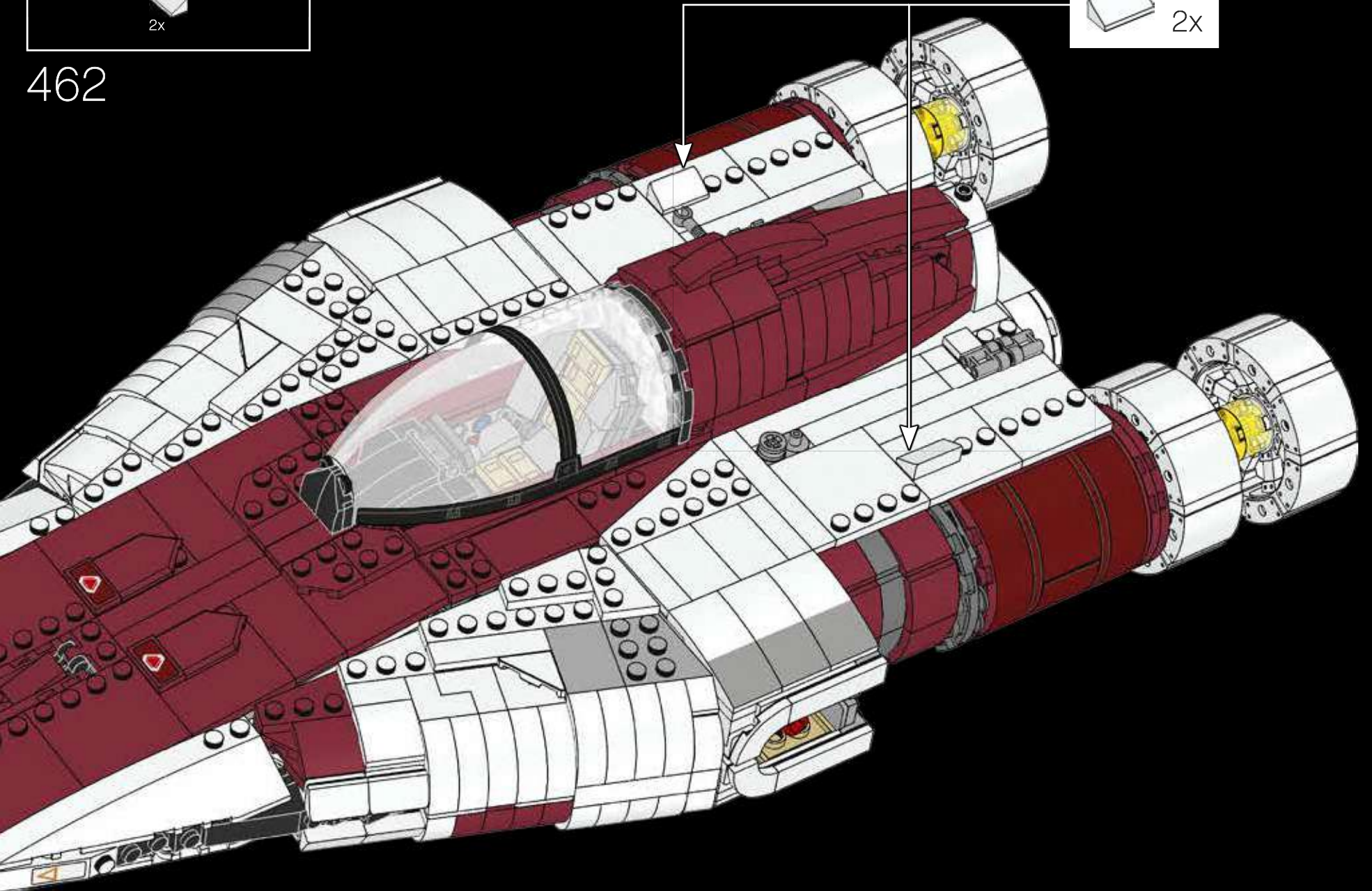

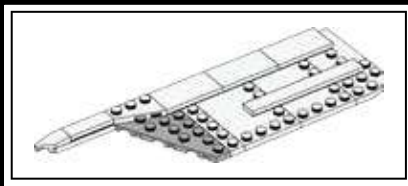

463

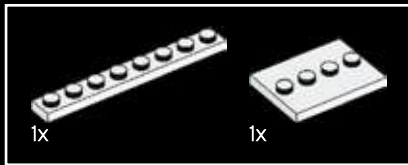
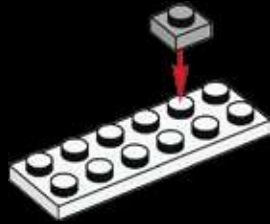

464

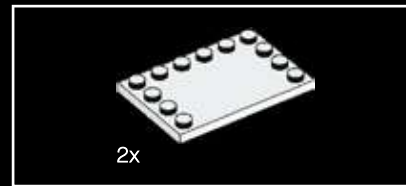
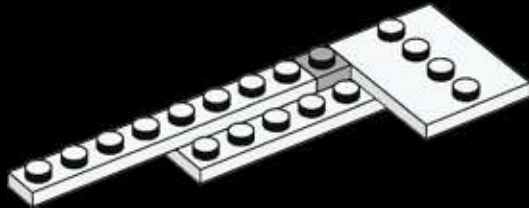

465

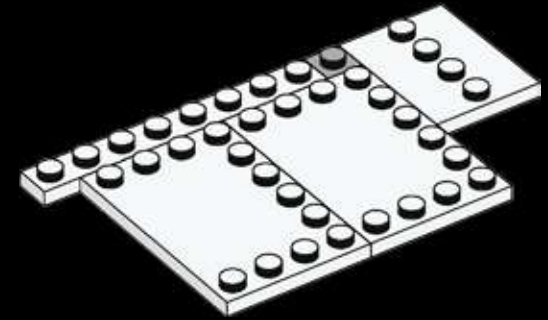

466

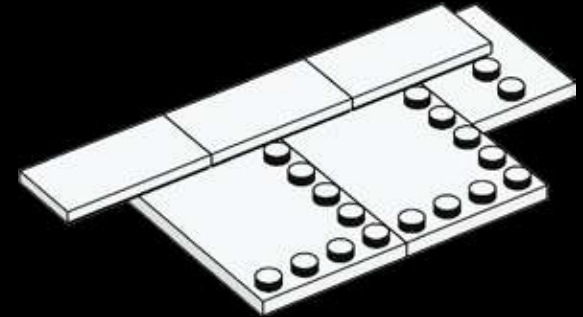

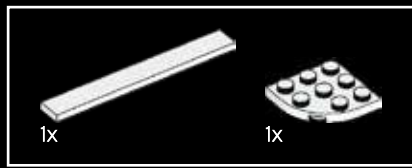

467

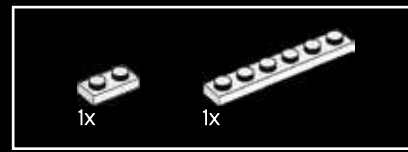
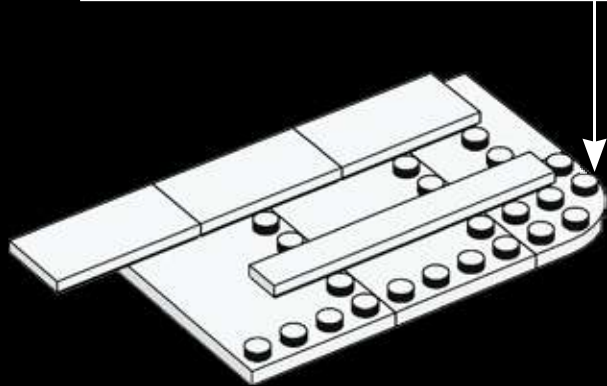
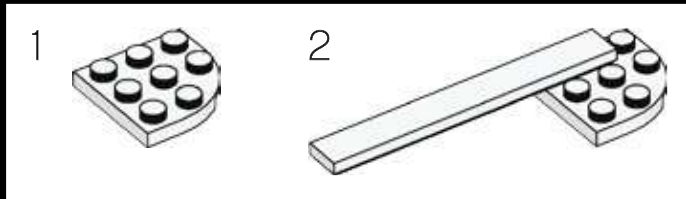

468

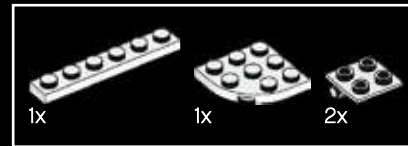
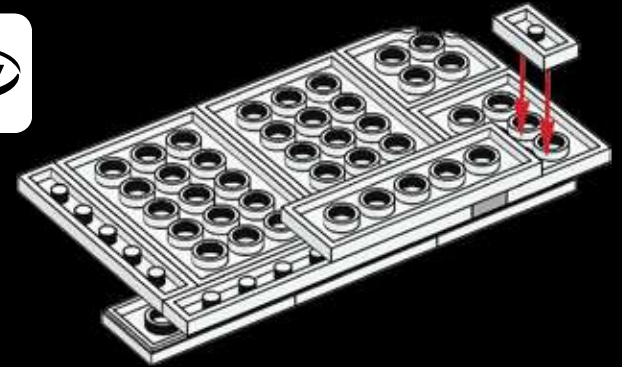

469



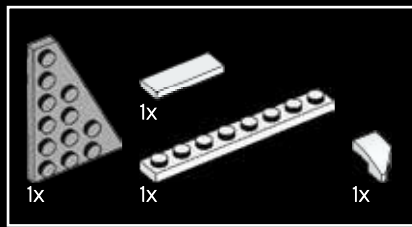

470

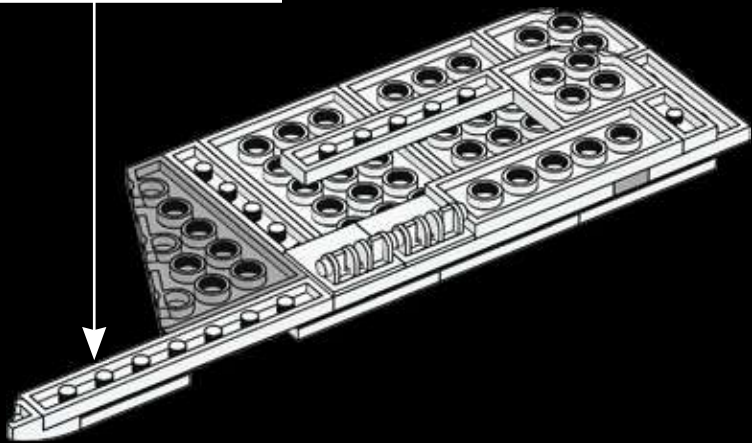
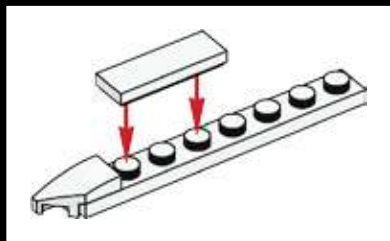

471

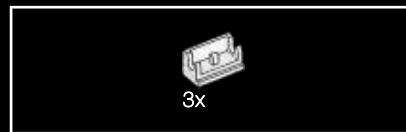
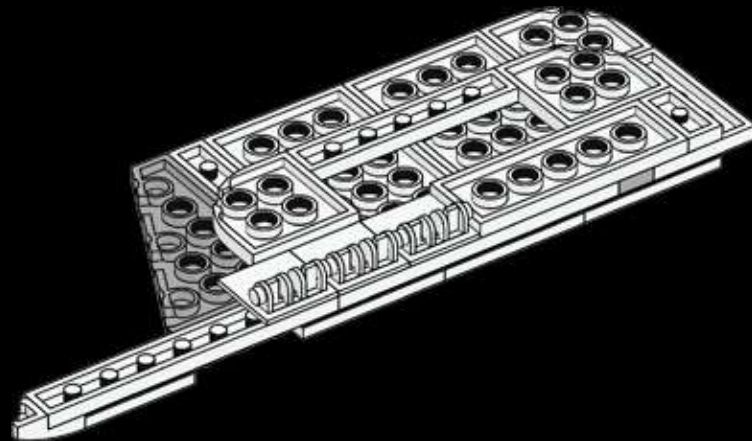

472

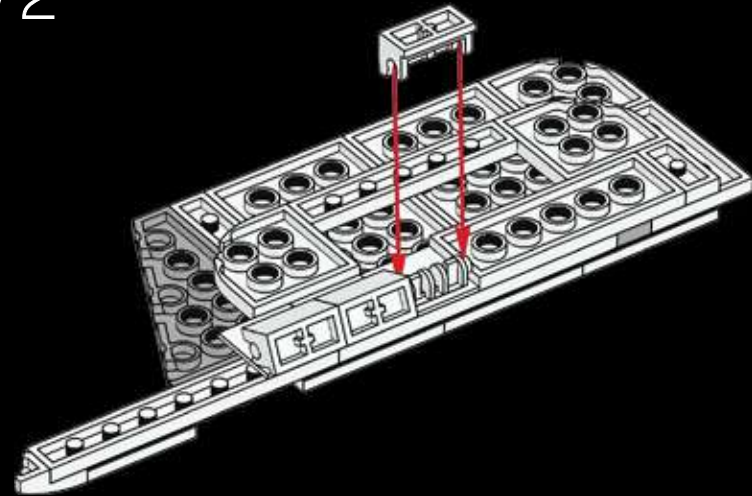



473

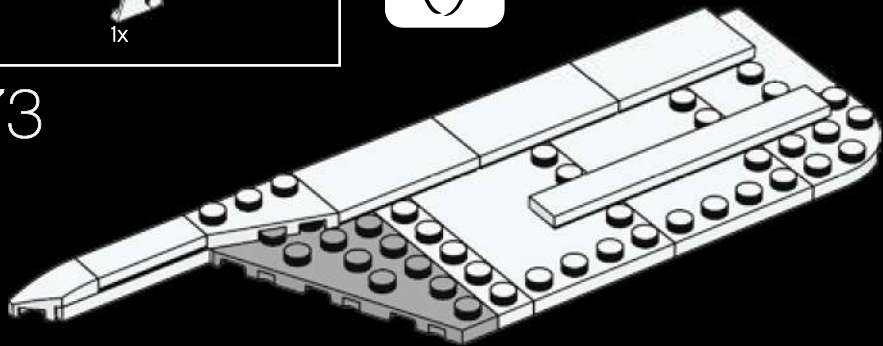

474

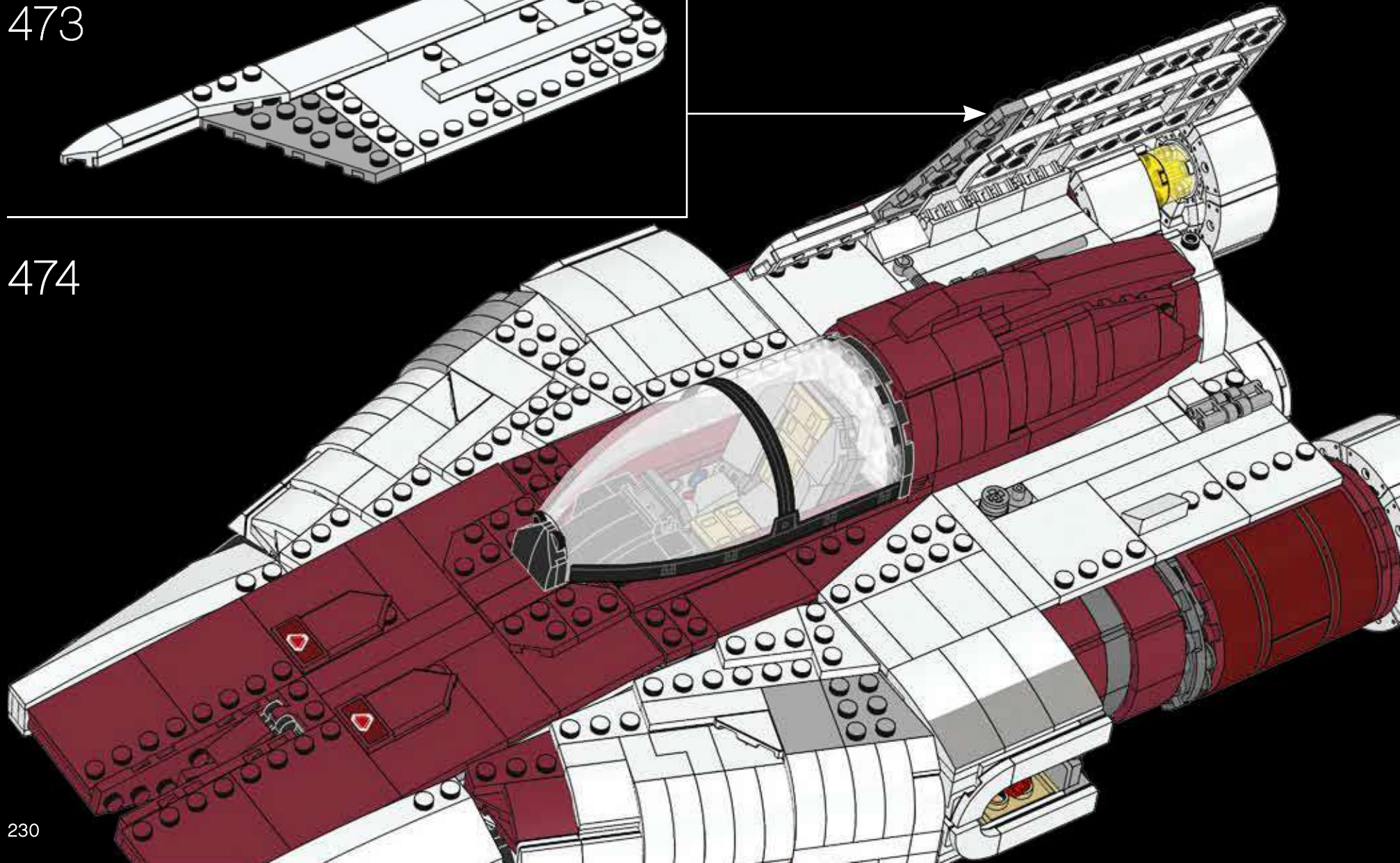

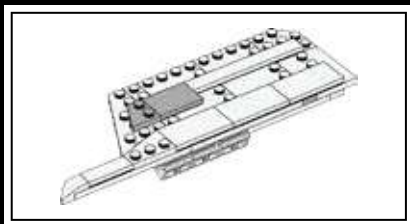

475

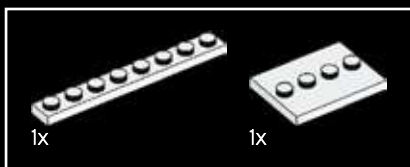
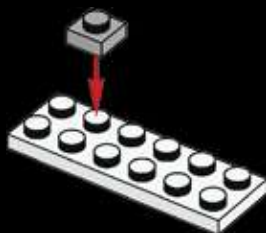

476

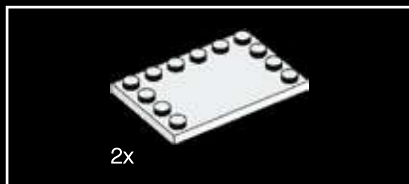
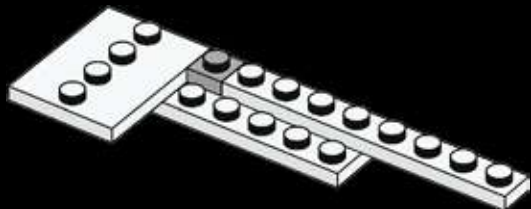

477

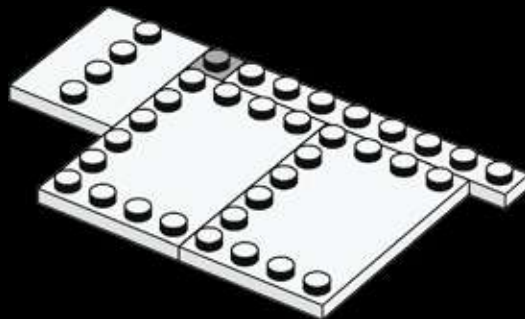

478

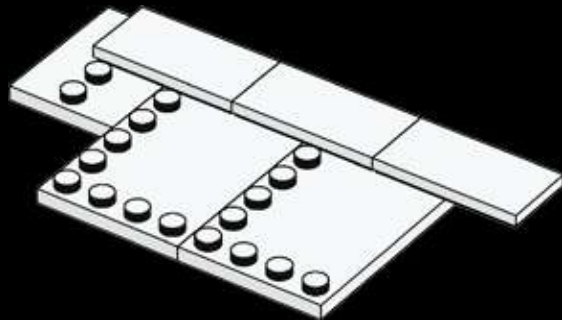

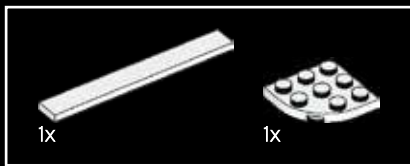

479

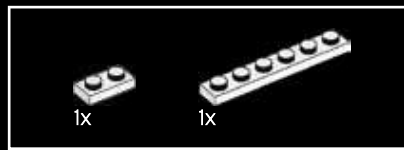
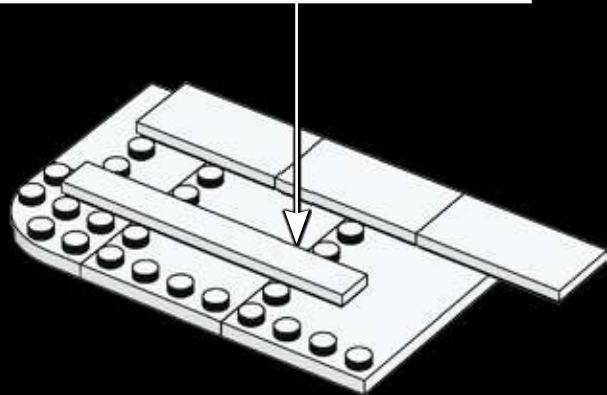
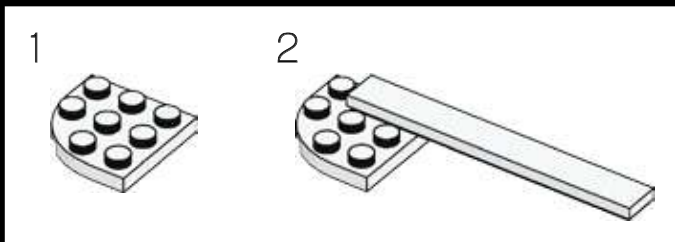

480

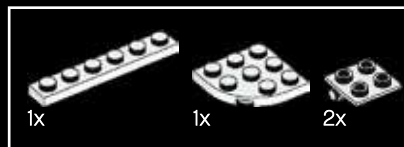
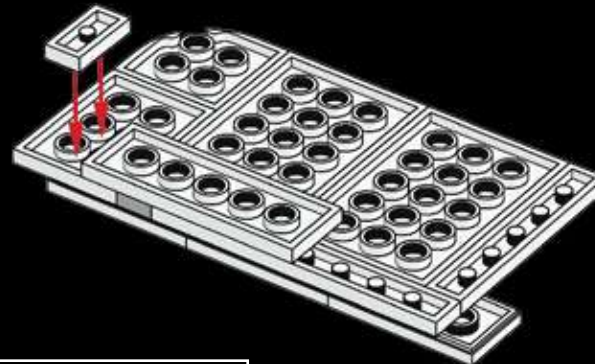

481

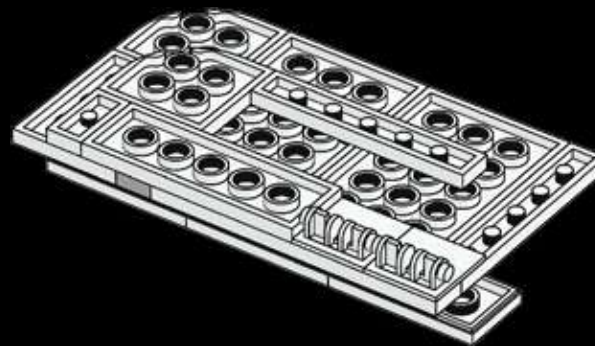



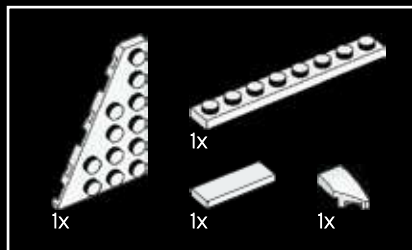

482

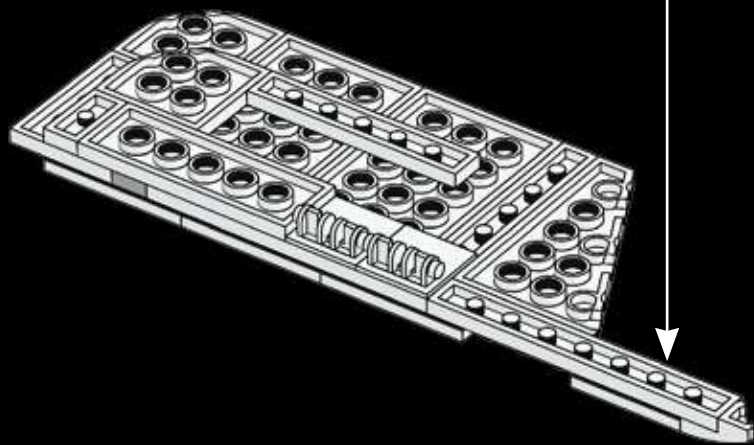
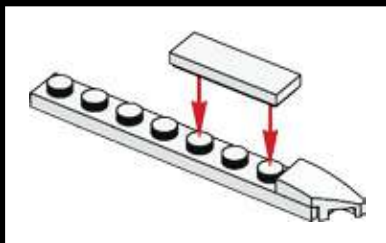

483

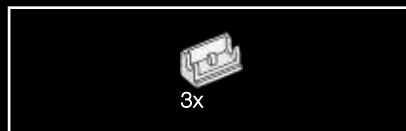
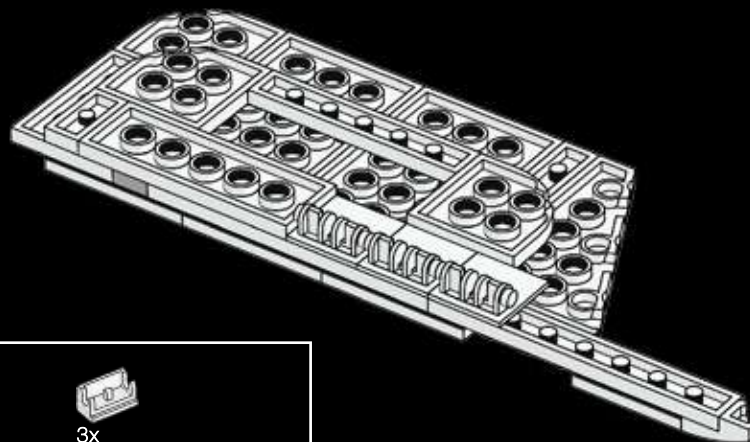

484

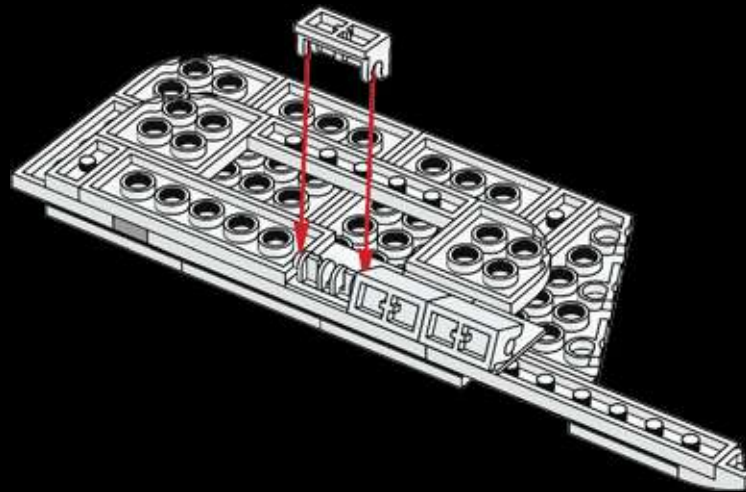

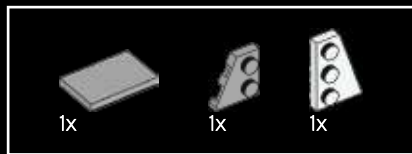

485

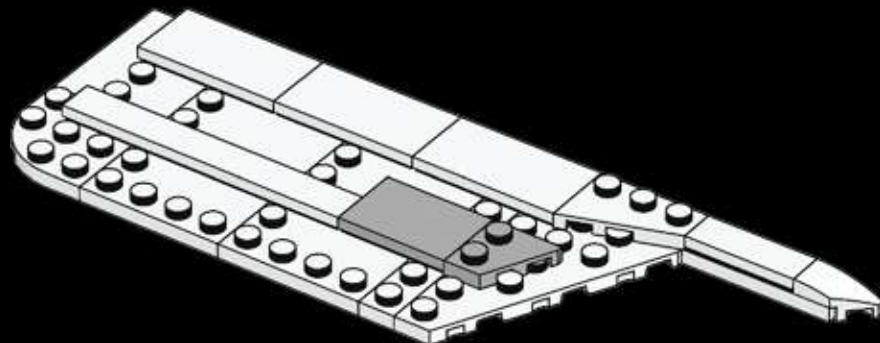

486

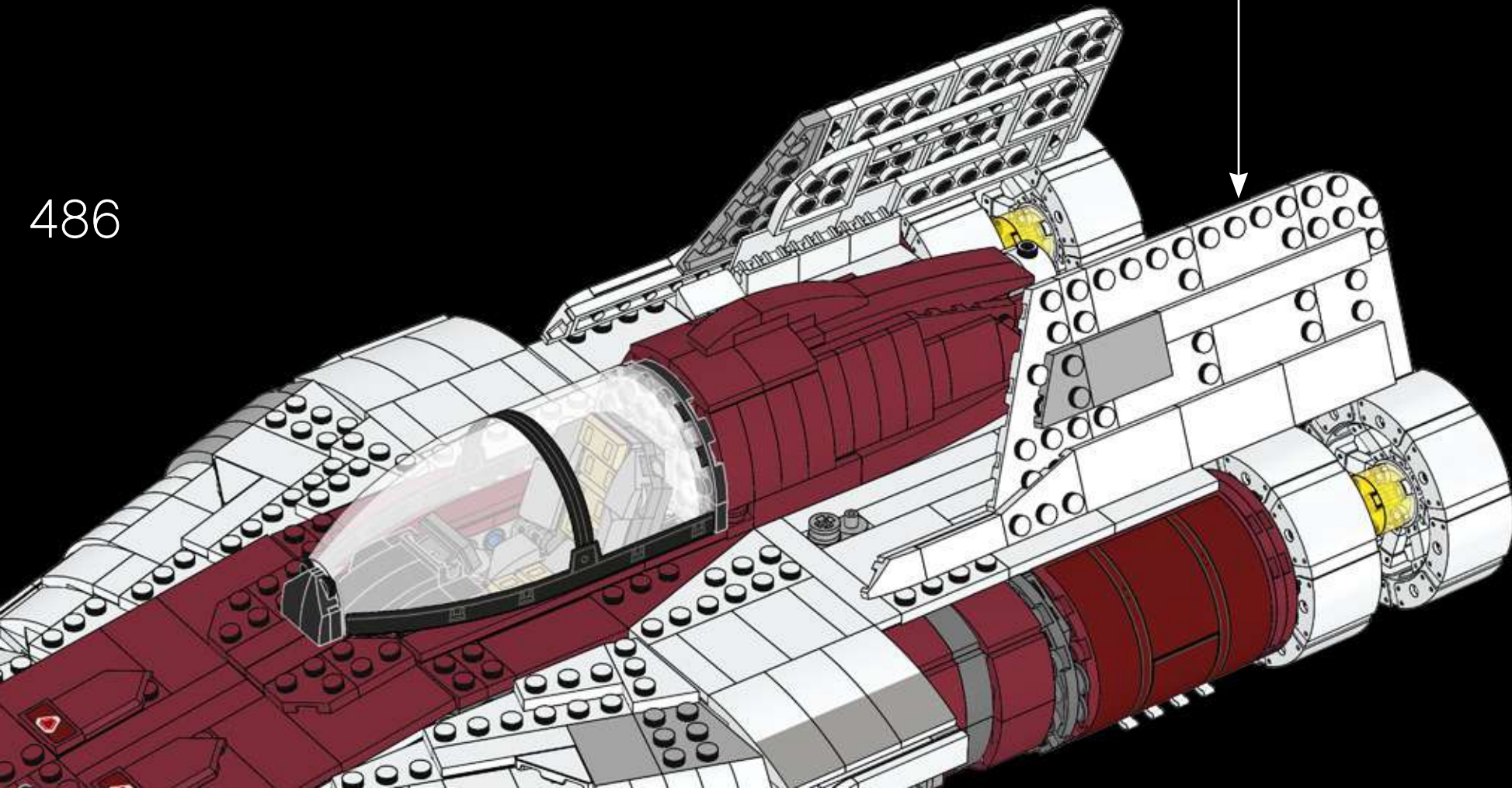



1x

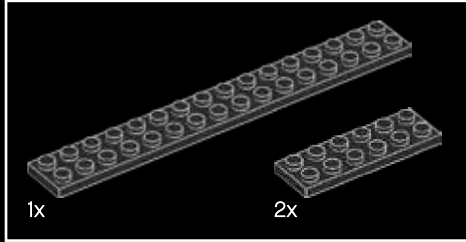
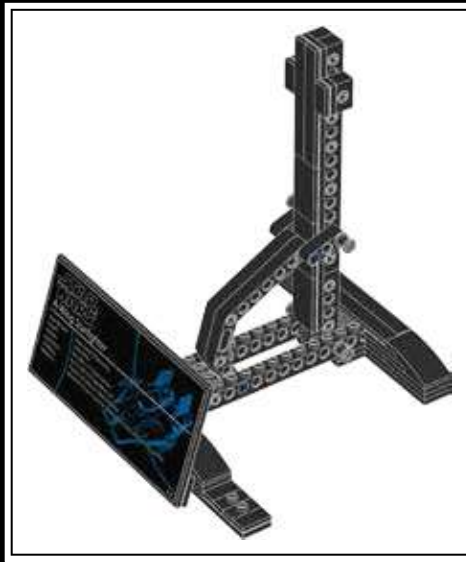
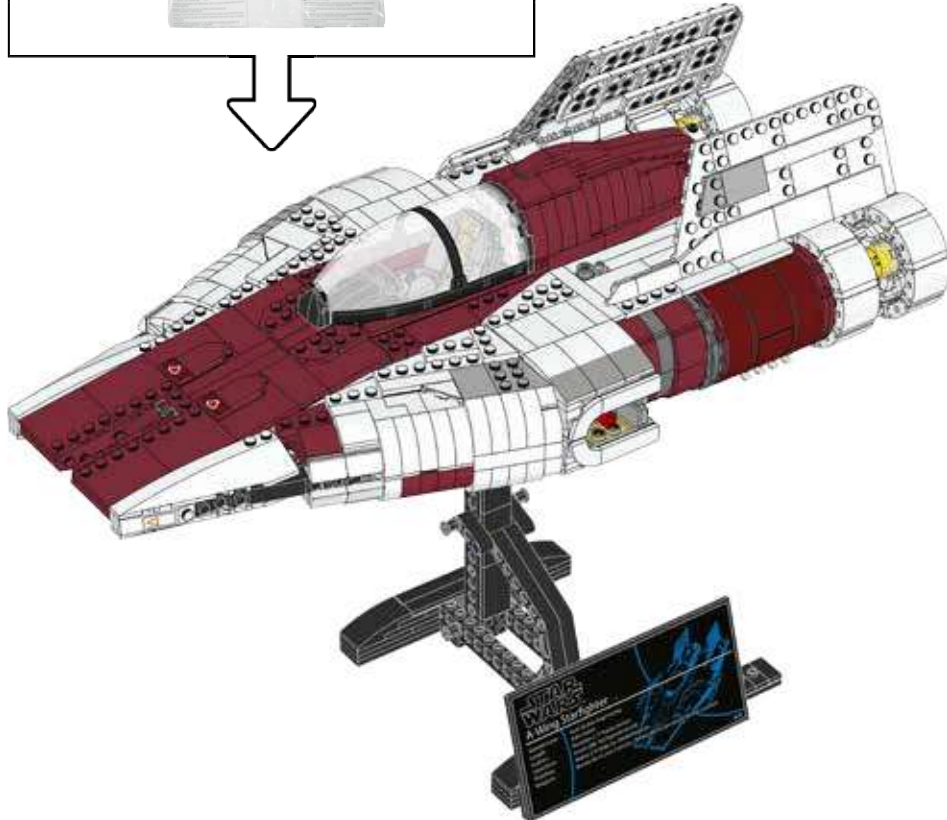

1x

2x

487

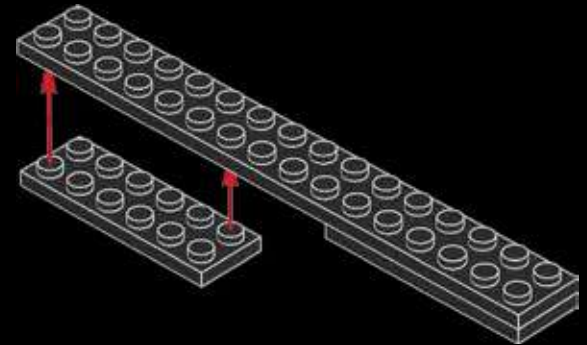

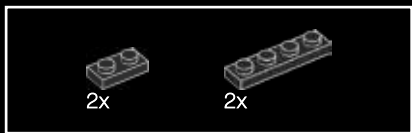

488

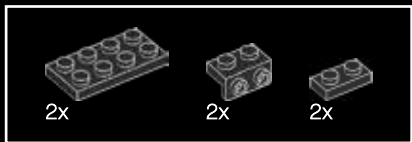
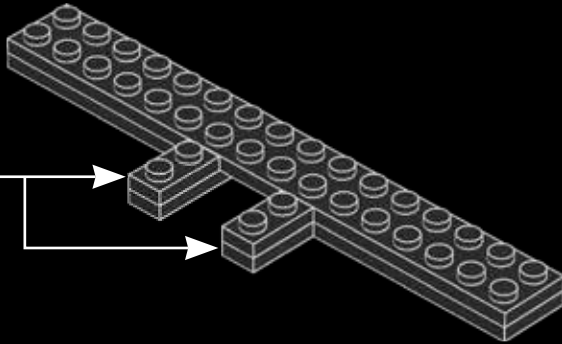
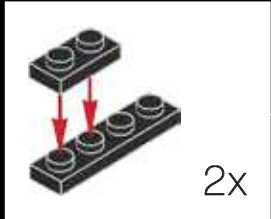

489

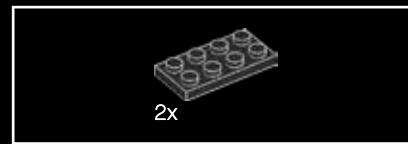
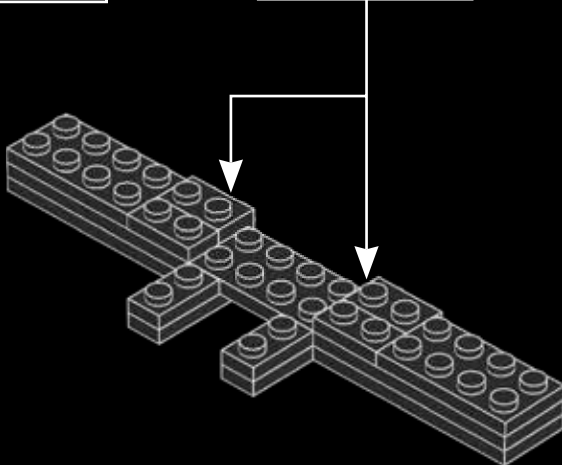

490

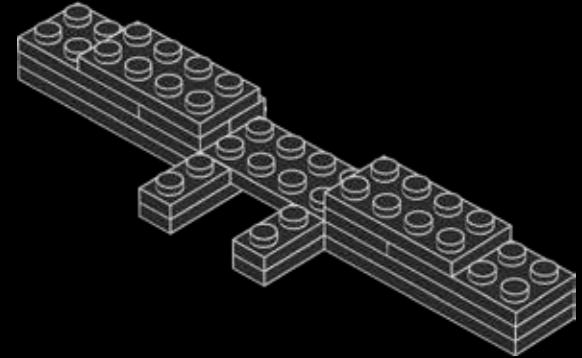

491

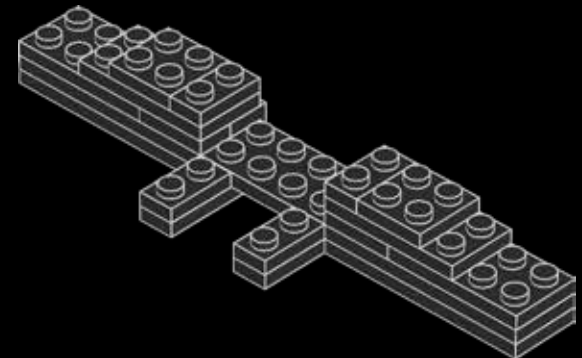



492

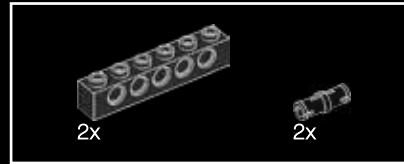
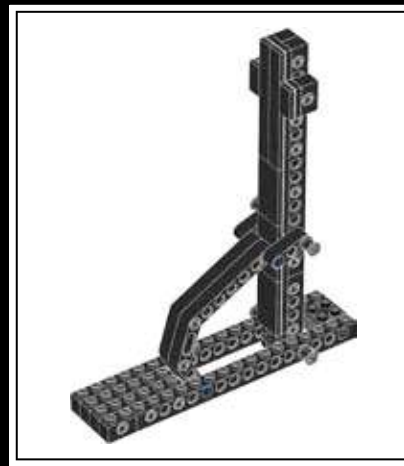
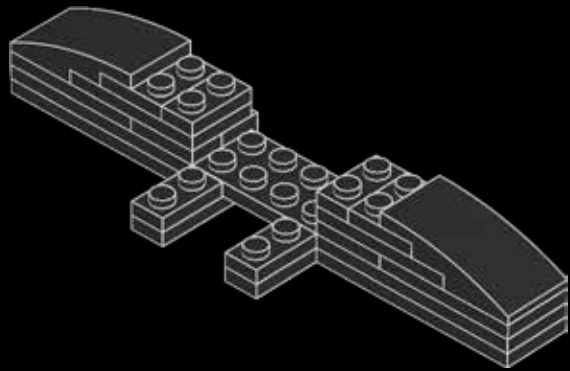

493

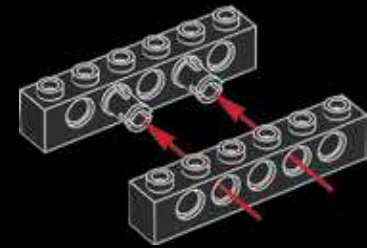

6x

494



2x

495



1x

1x

1x

496

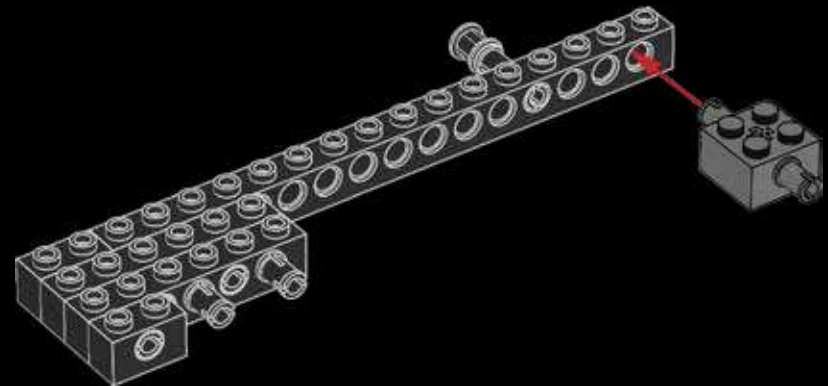

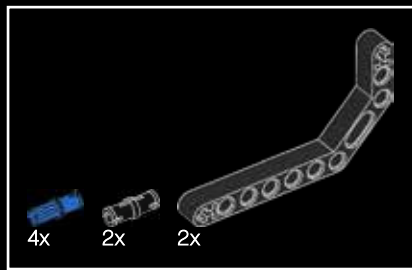

497

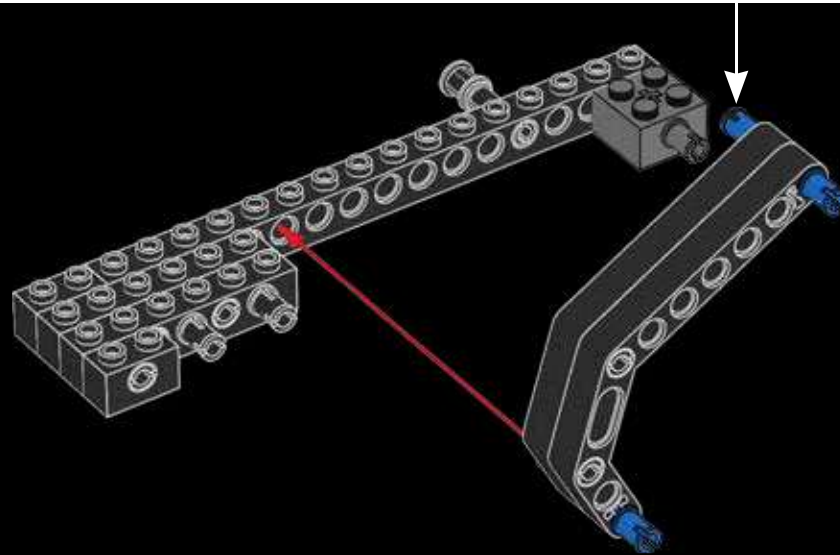

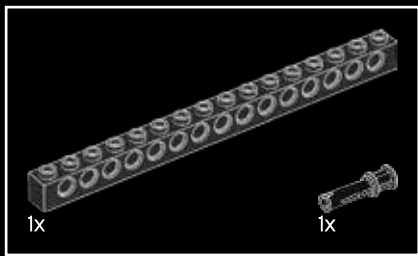

498

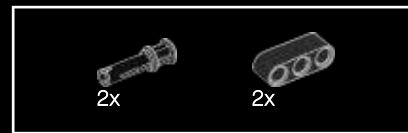
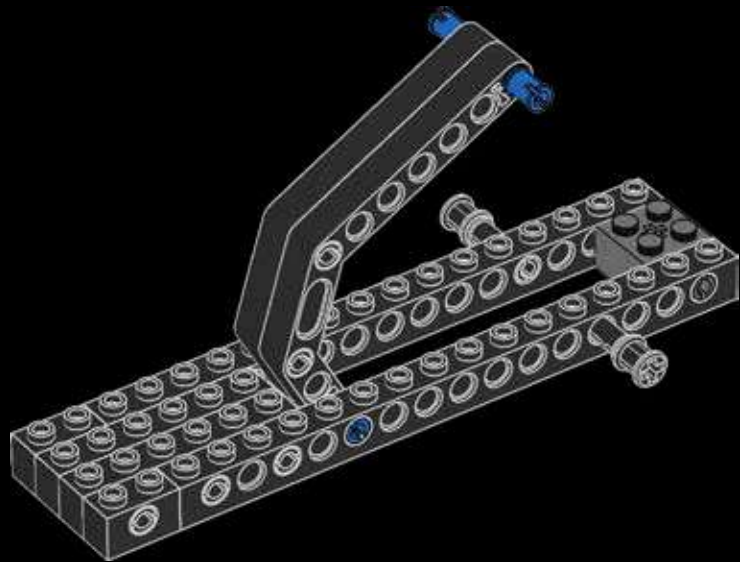

499

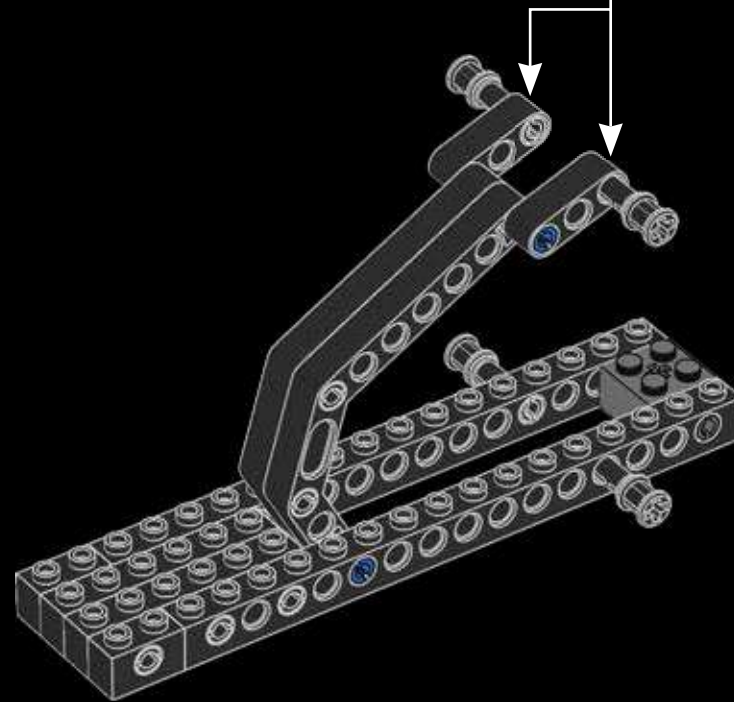



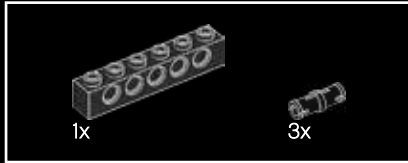
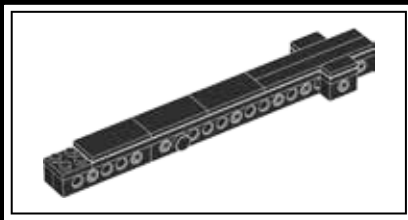

500

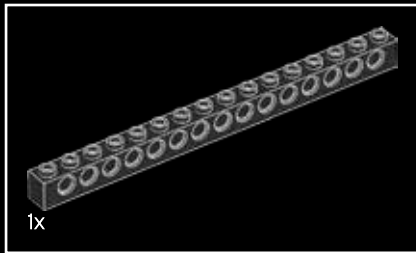
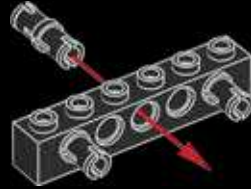

501

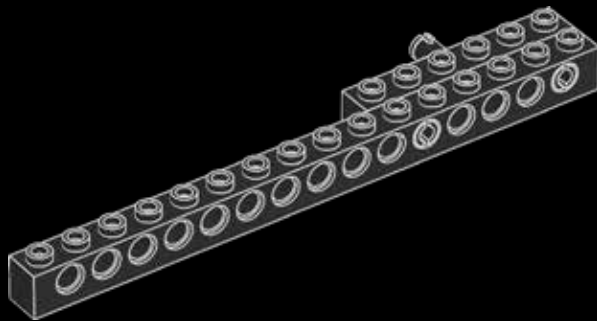

502

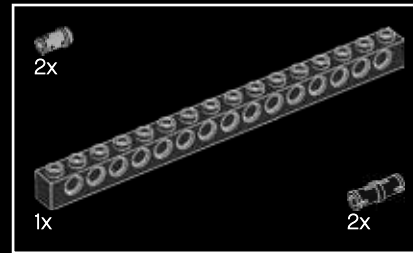
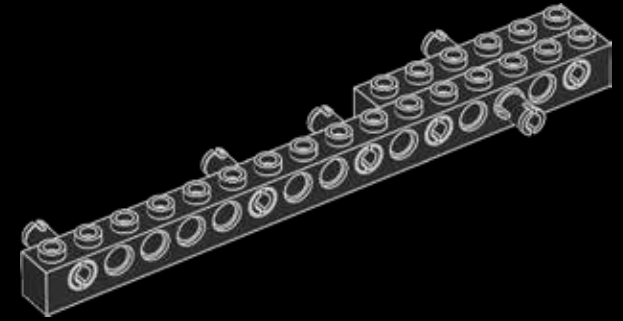

503

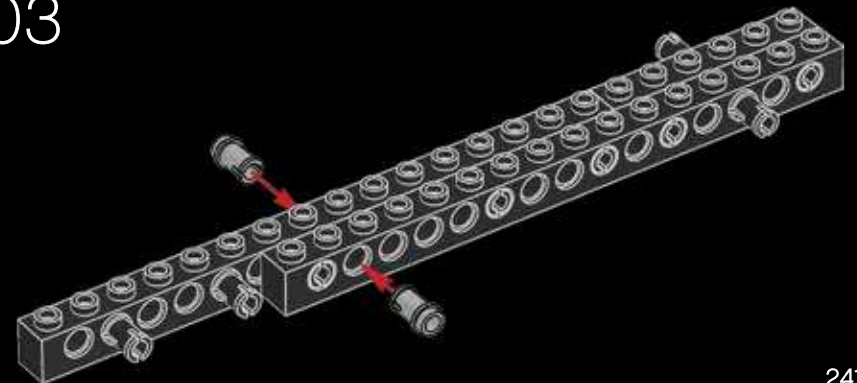

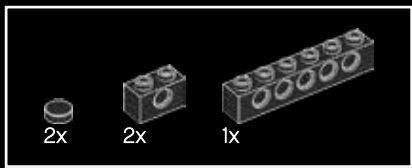

504

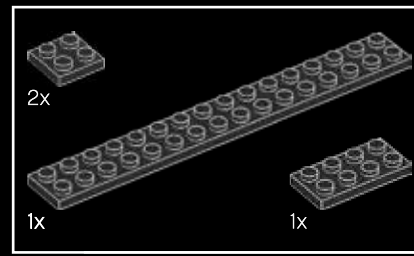
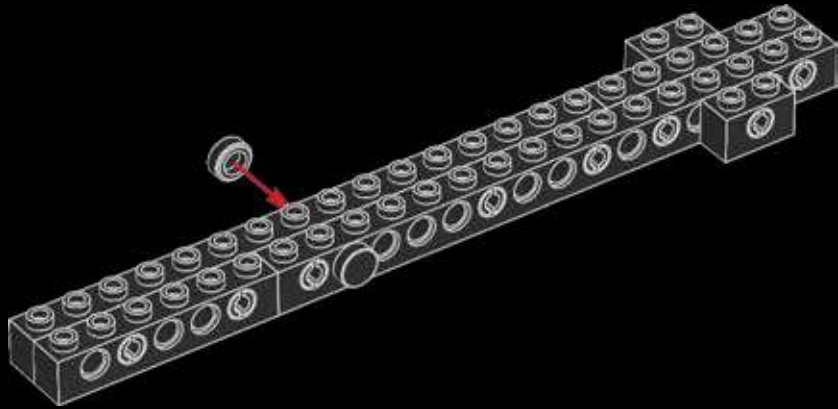

505

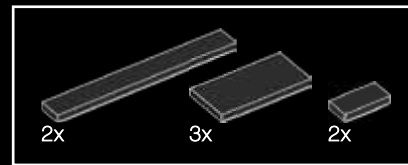
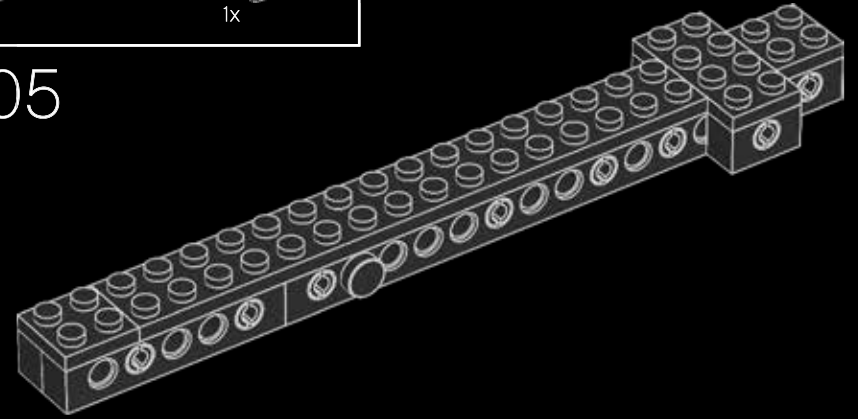

506

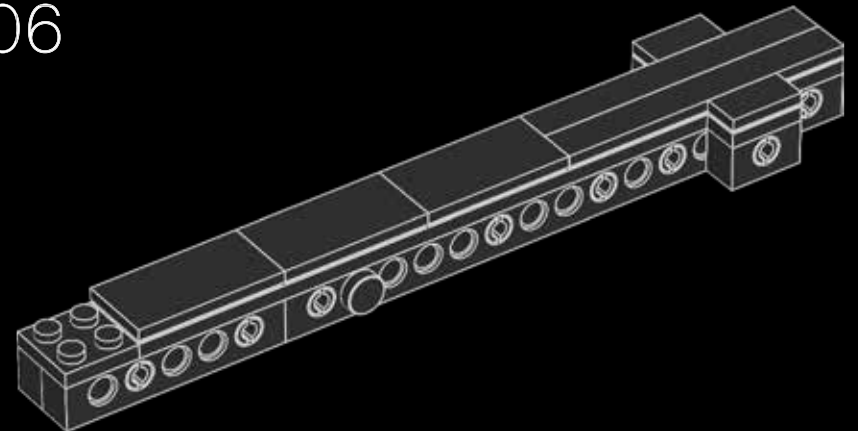

507

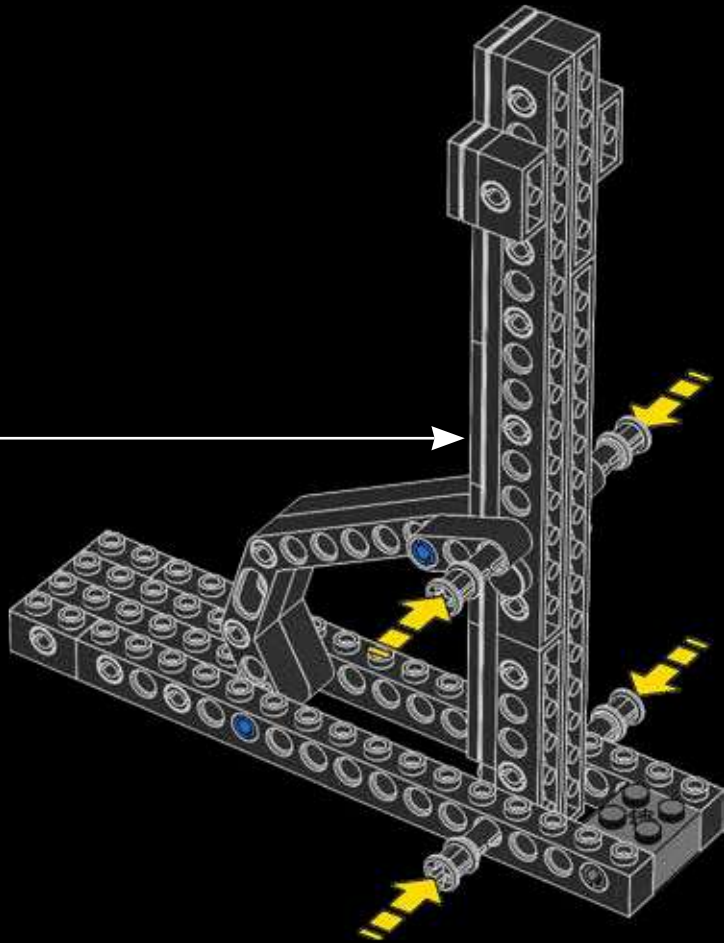

508

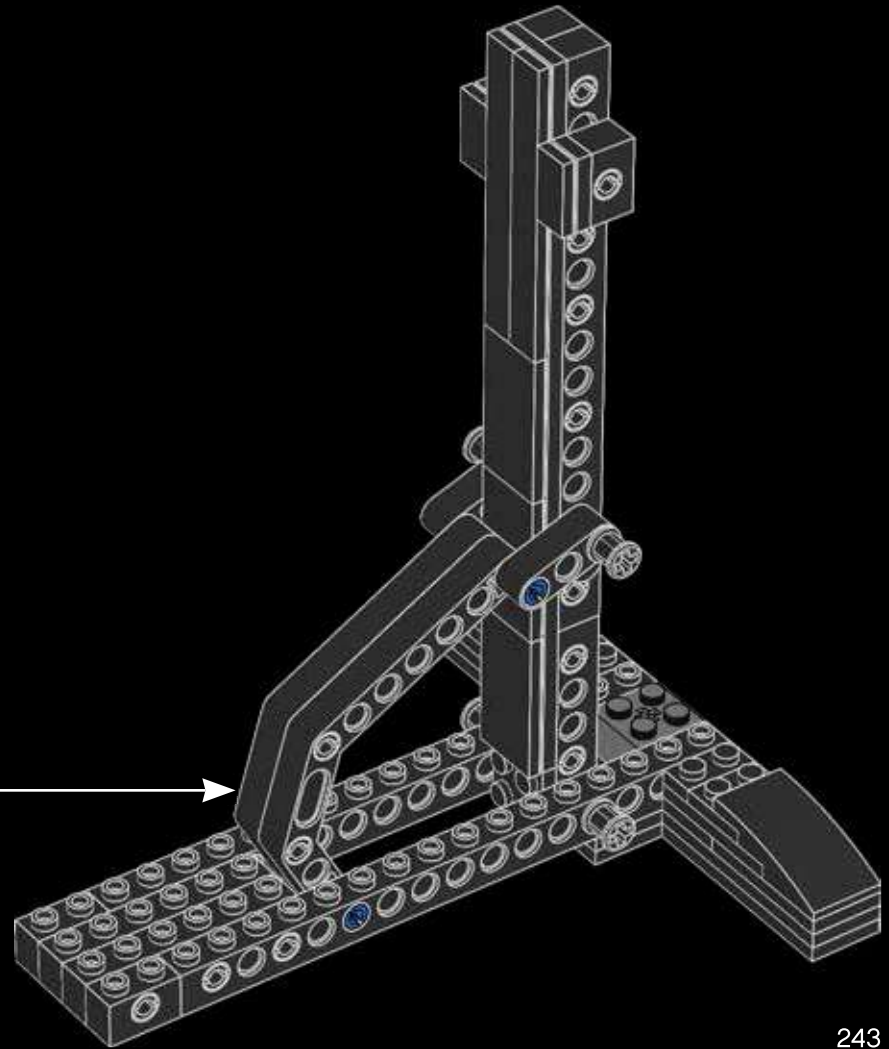

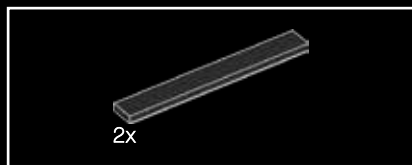

509

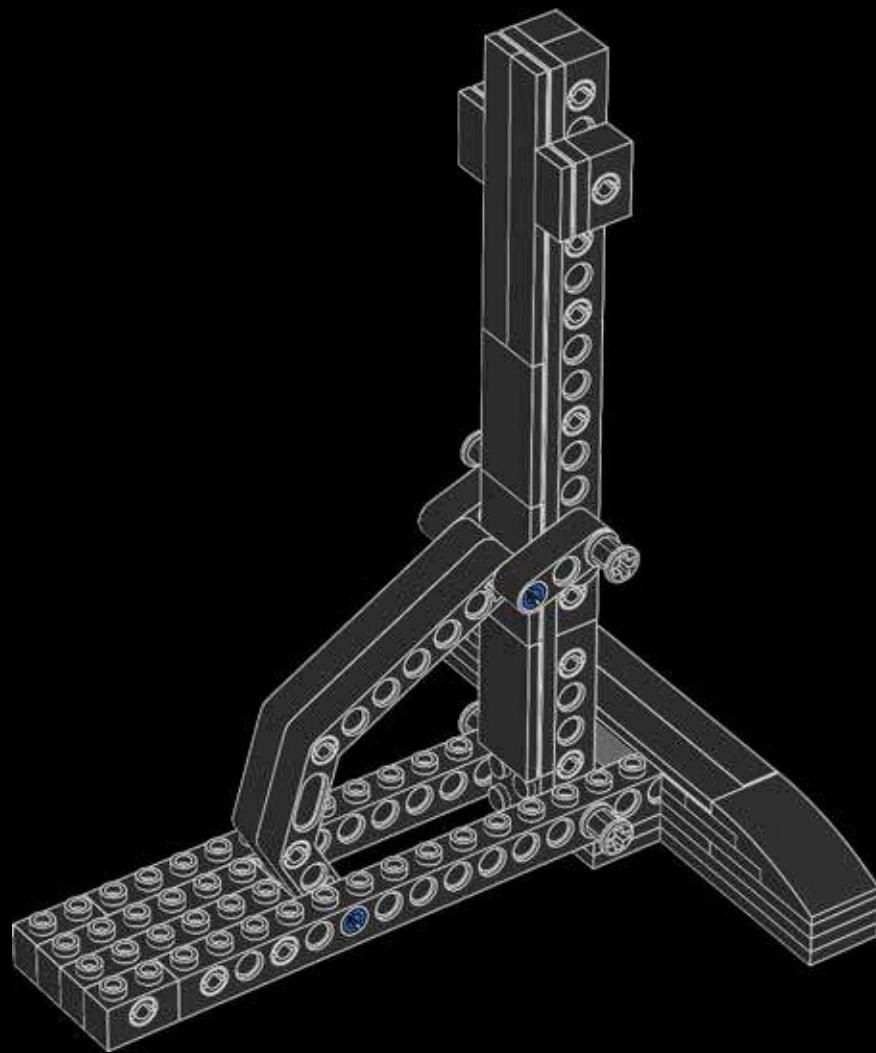

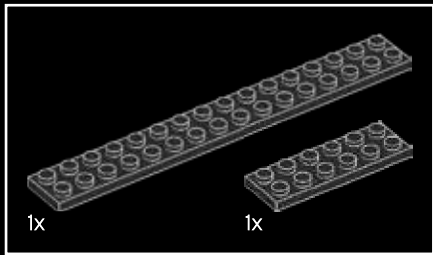
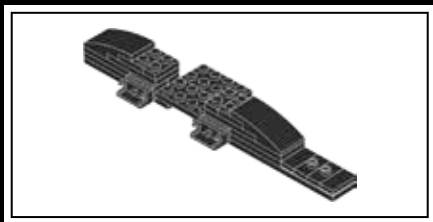

510

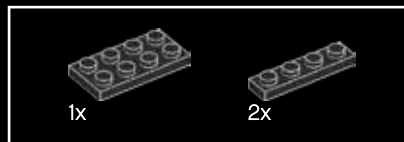
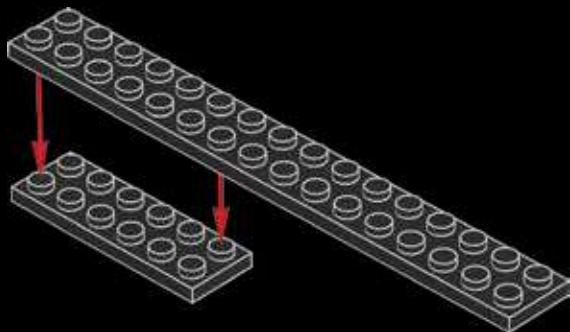

511

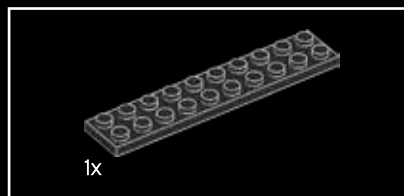
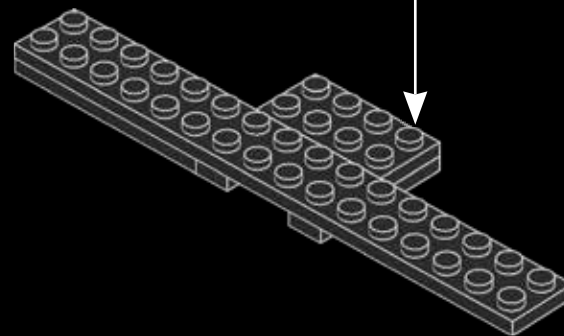
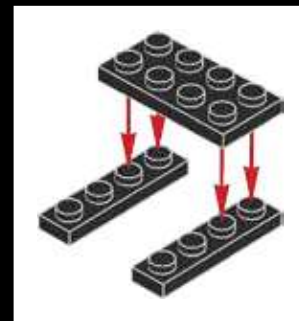

512

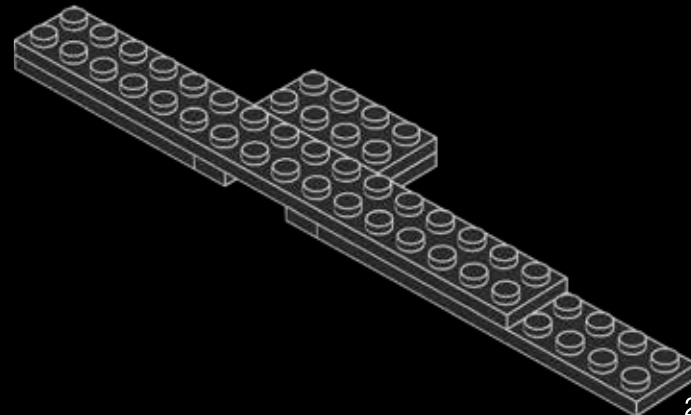

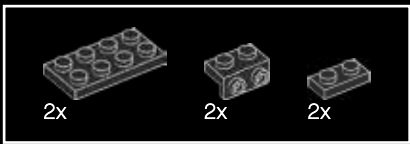

513

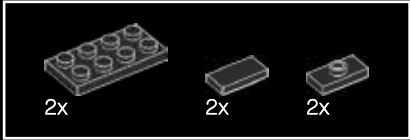
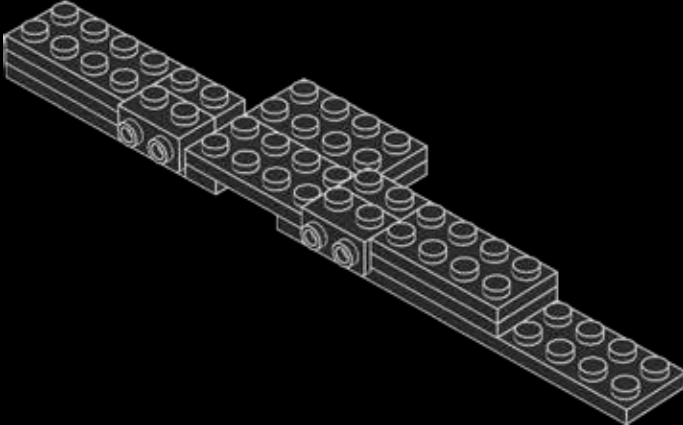

514

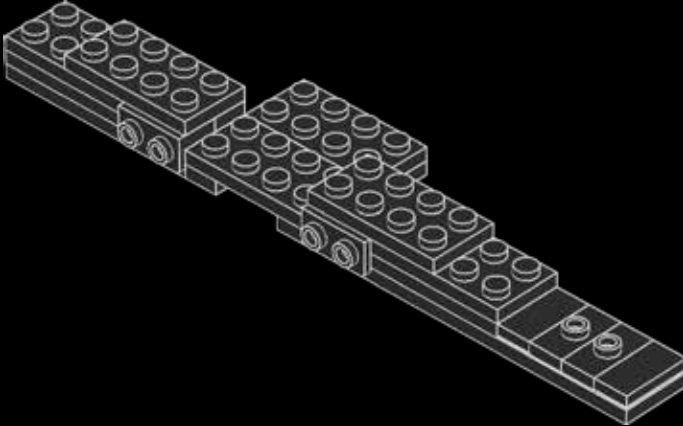

515

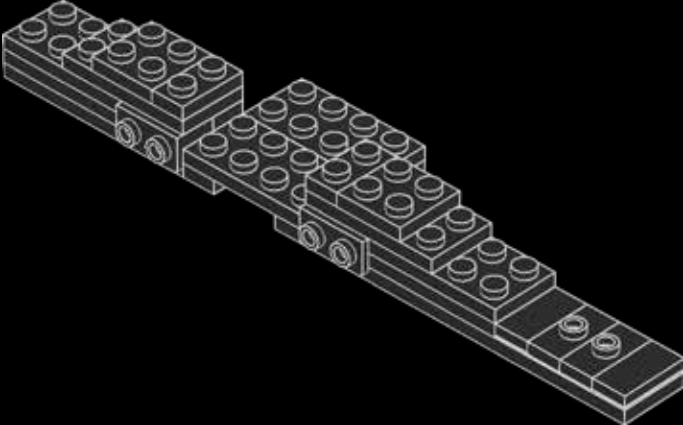

516

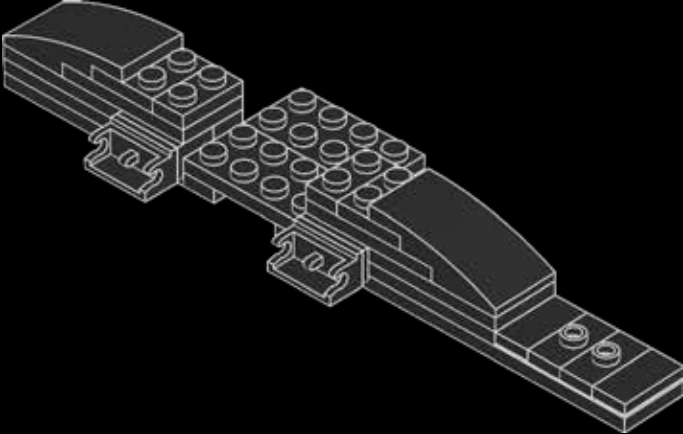

517

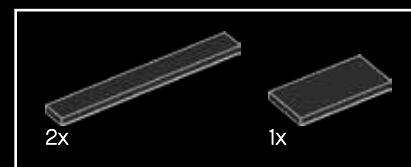
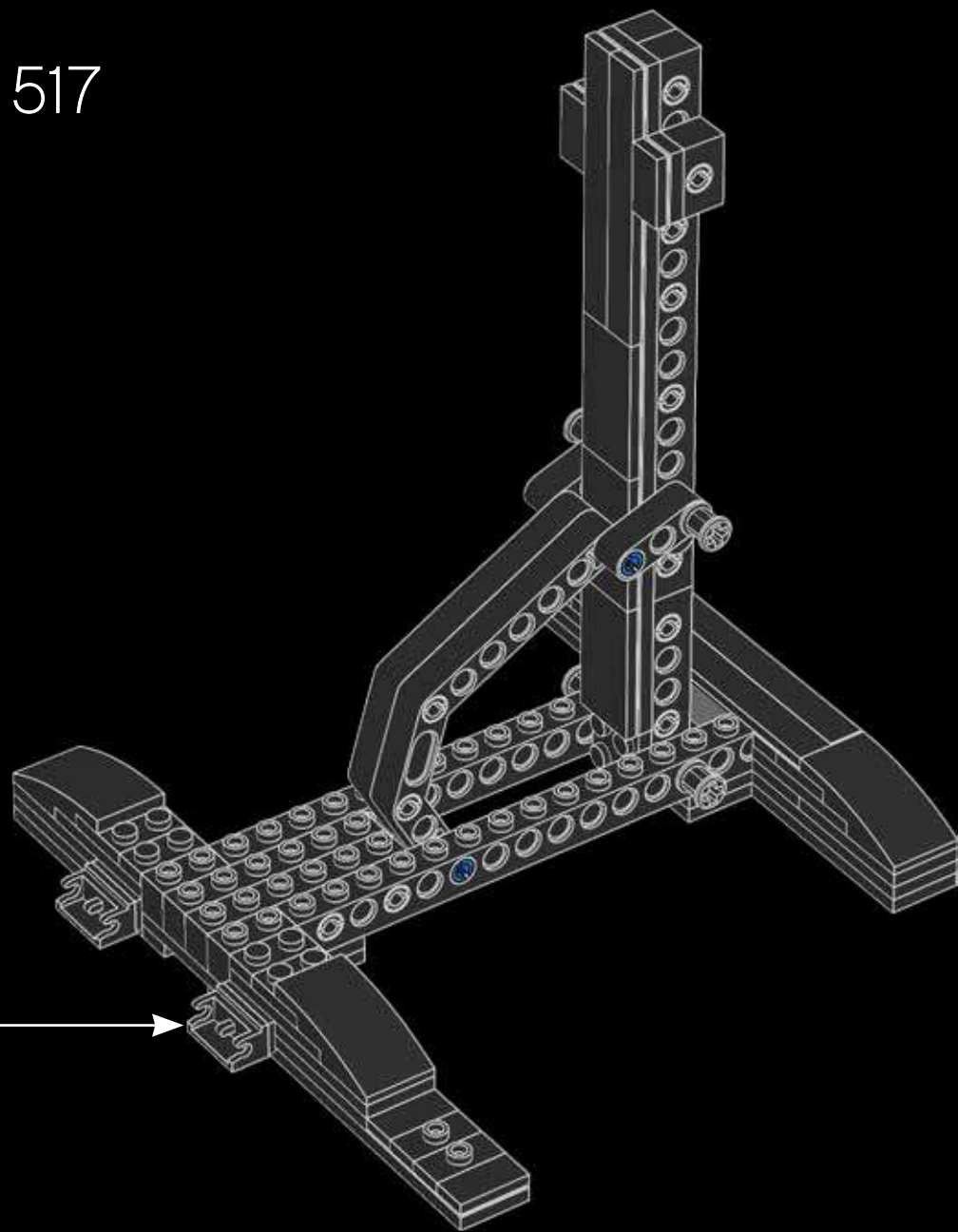

518

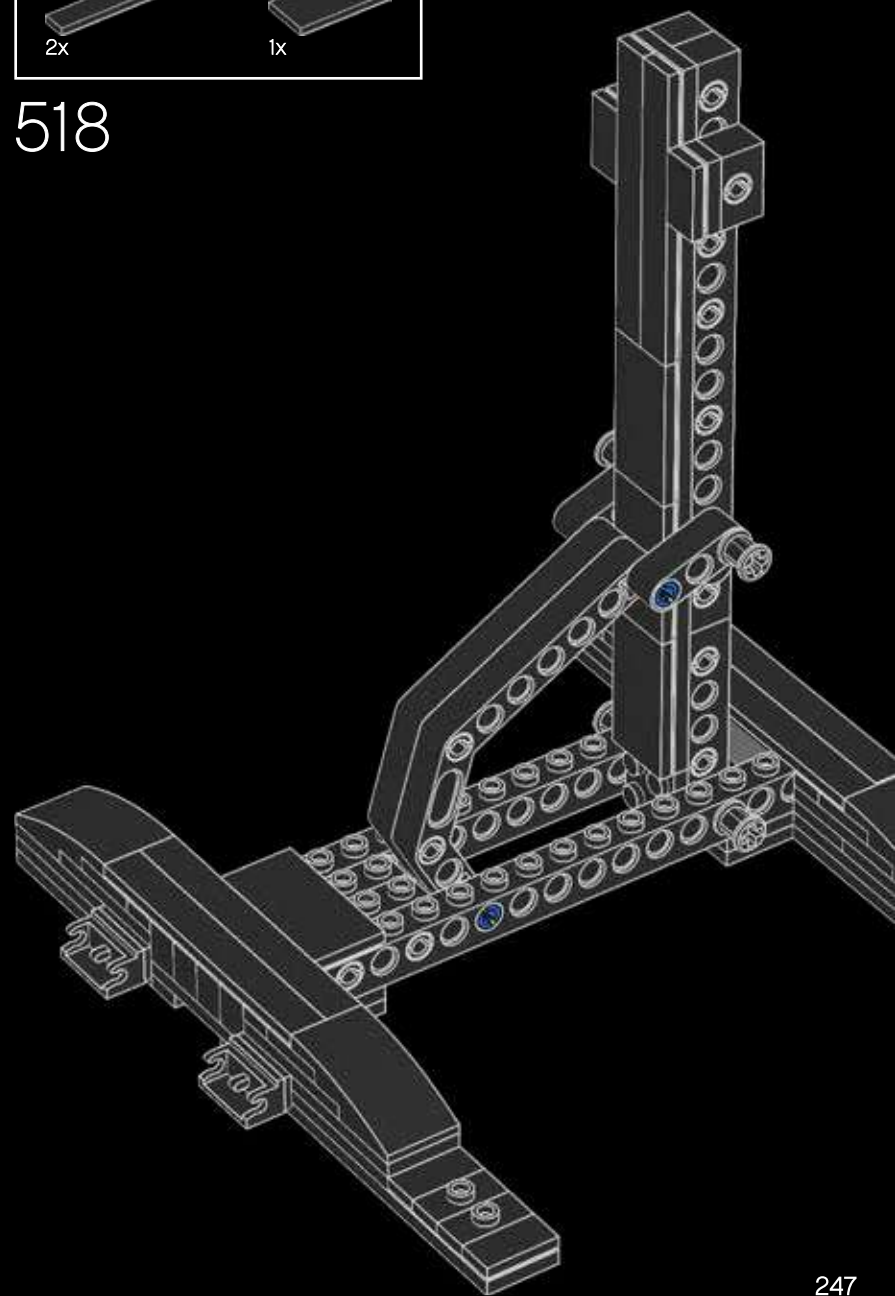

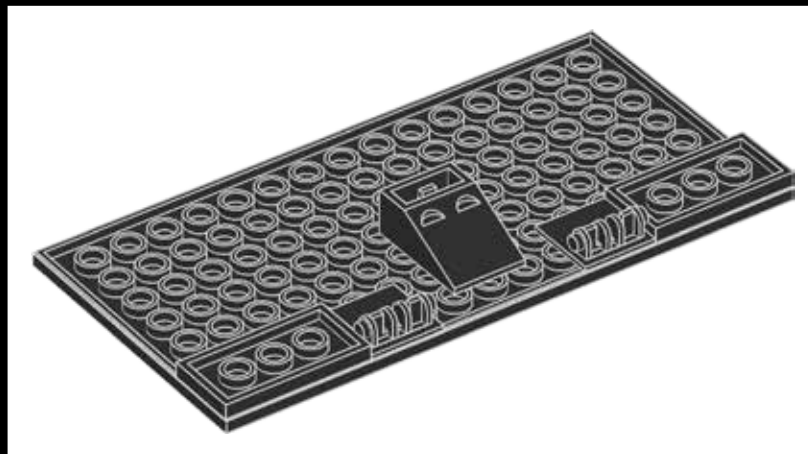
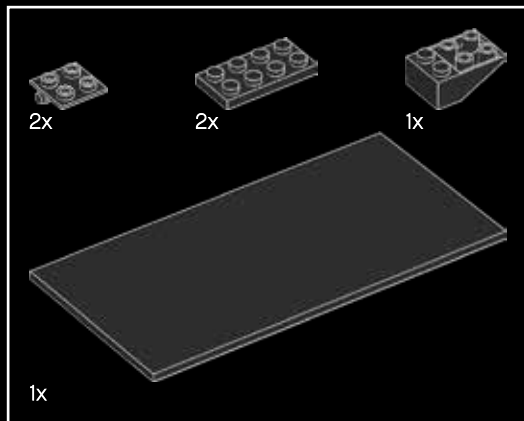

519

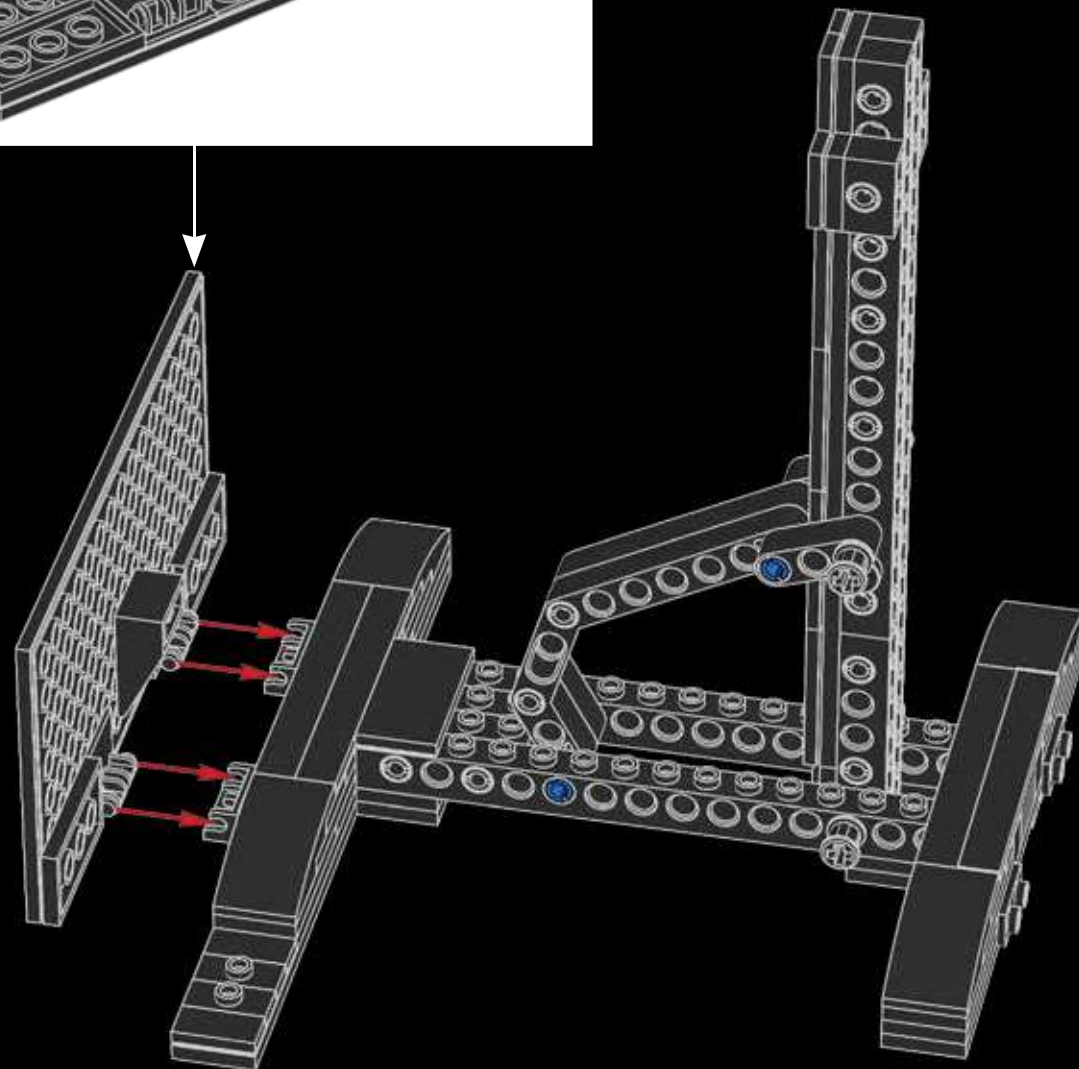



520

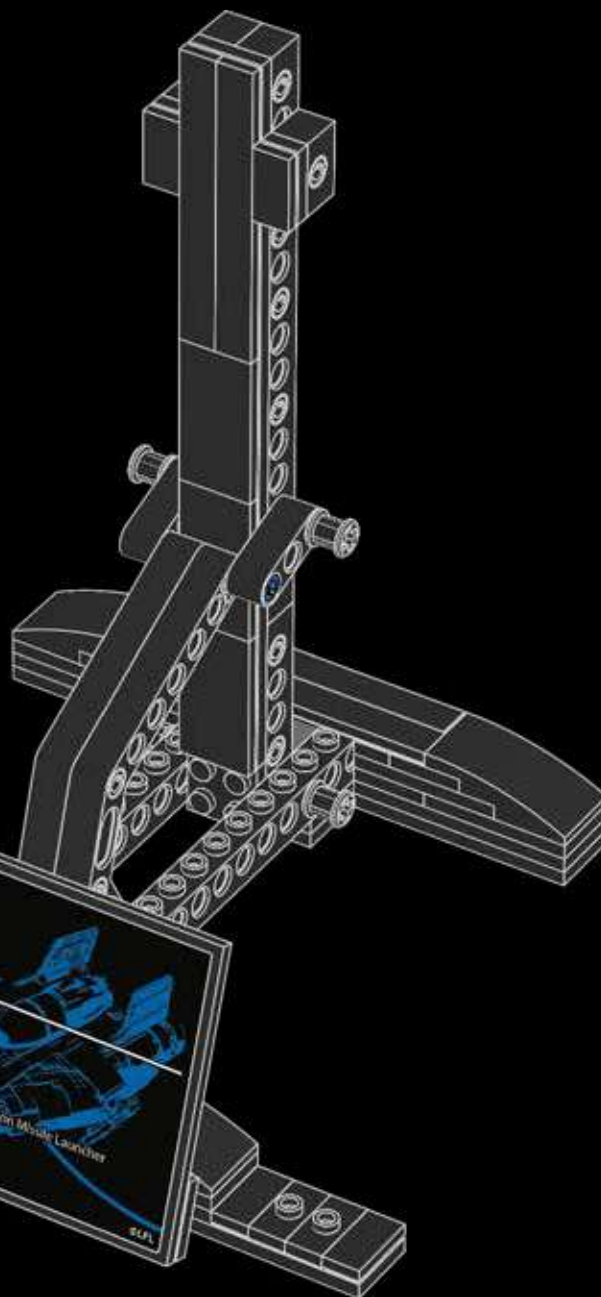
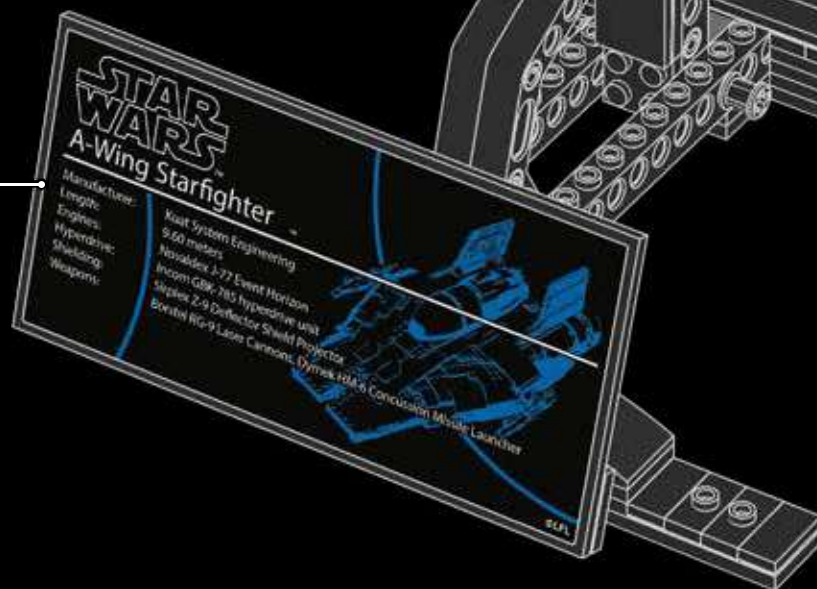

521

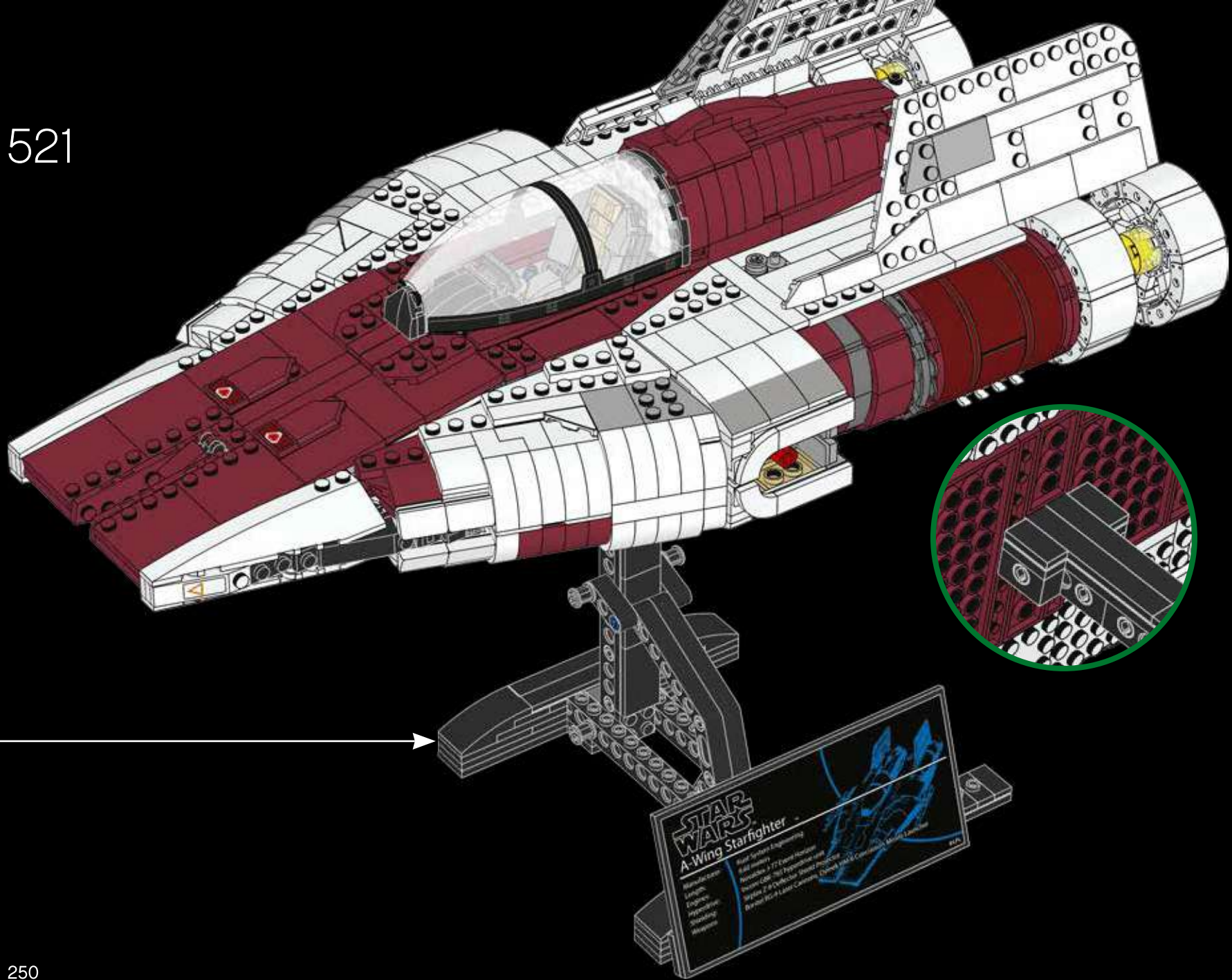



11

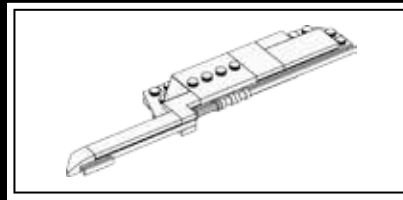
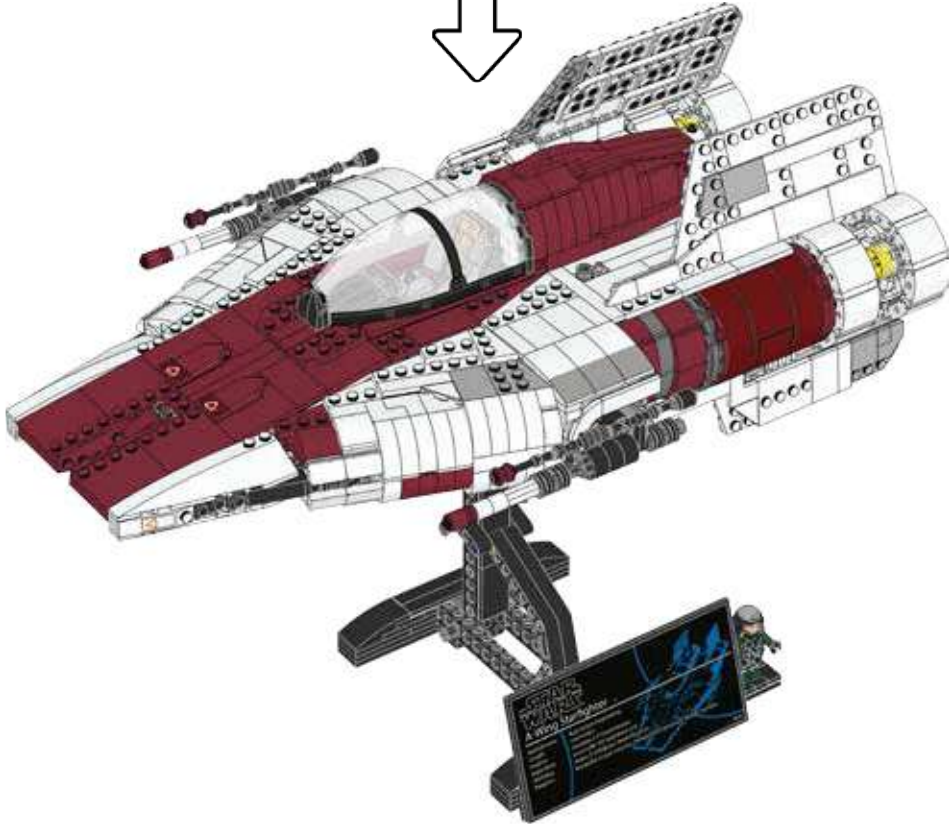
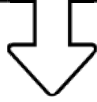

1x

522

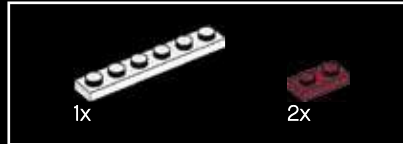

1x

2x

523

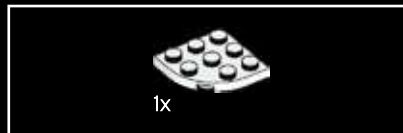

1x

524



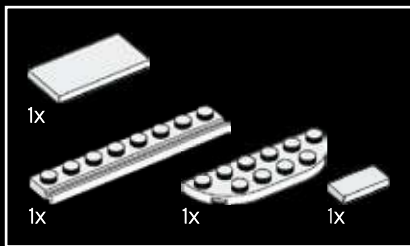

525

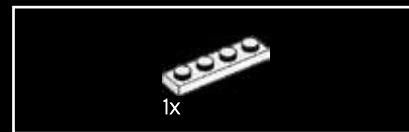
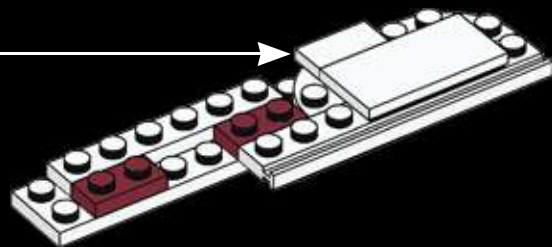
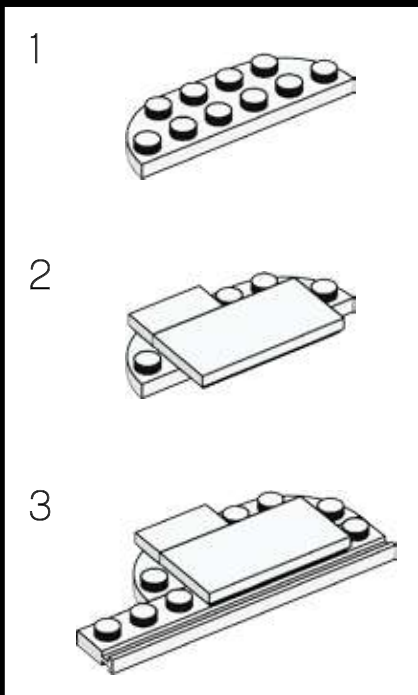

526

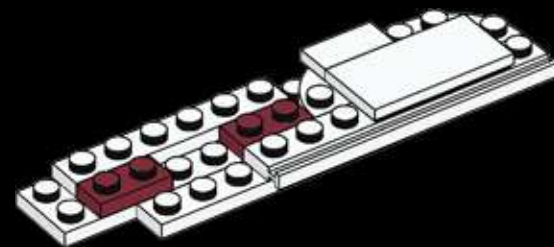

527

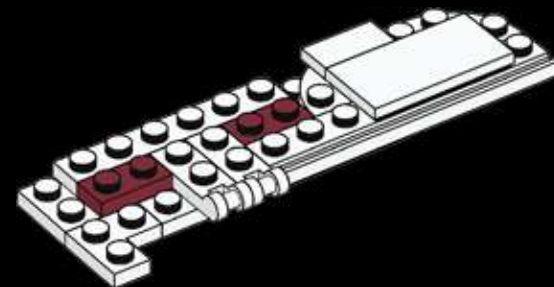



528

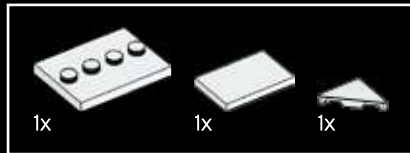
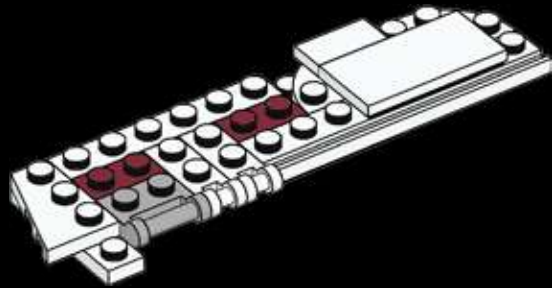

529

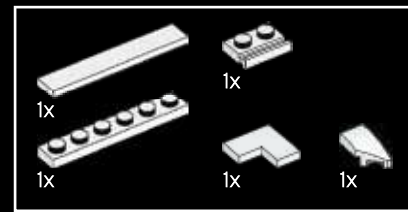
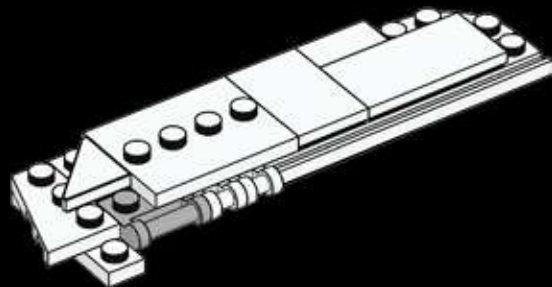

530

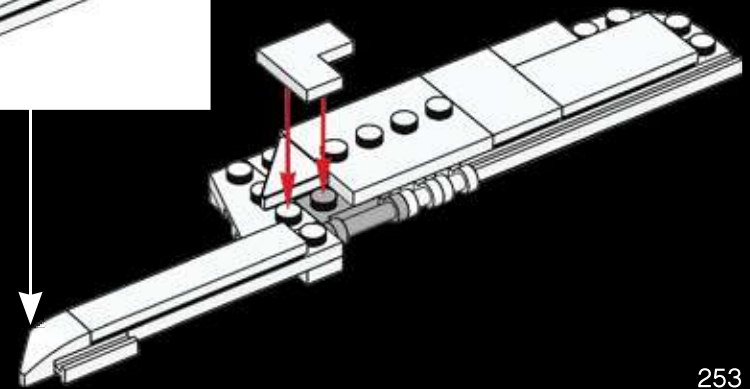
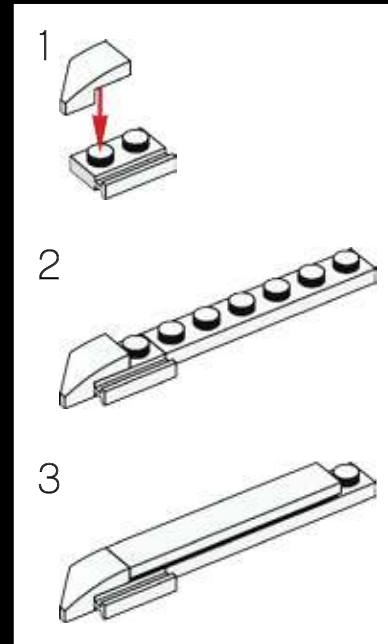

531

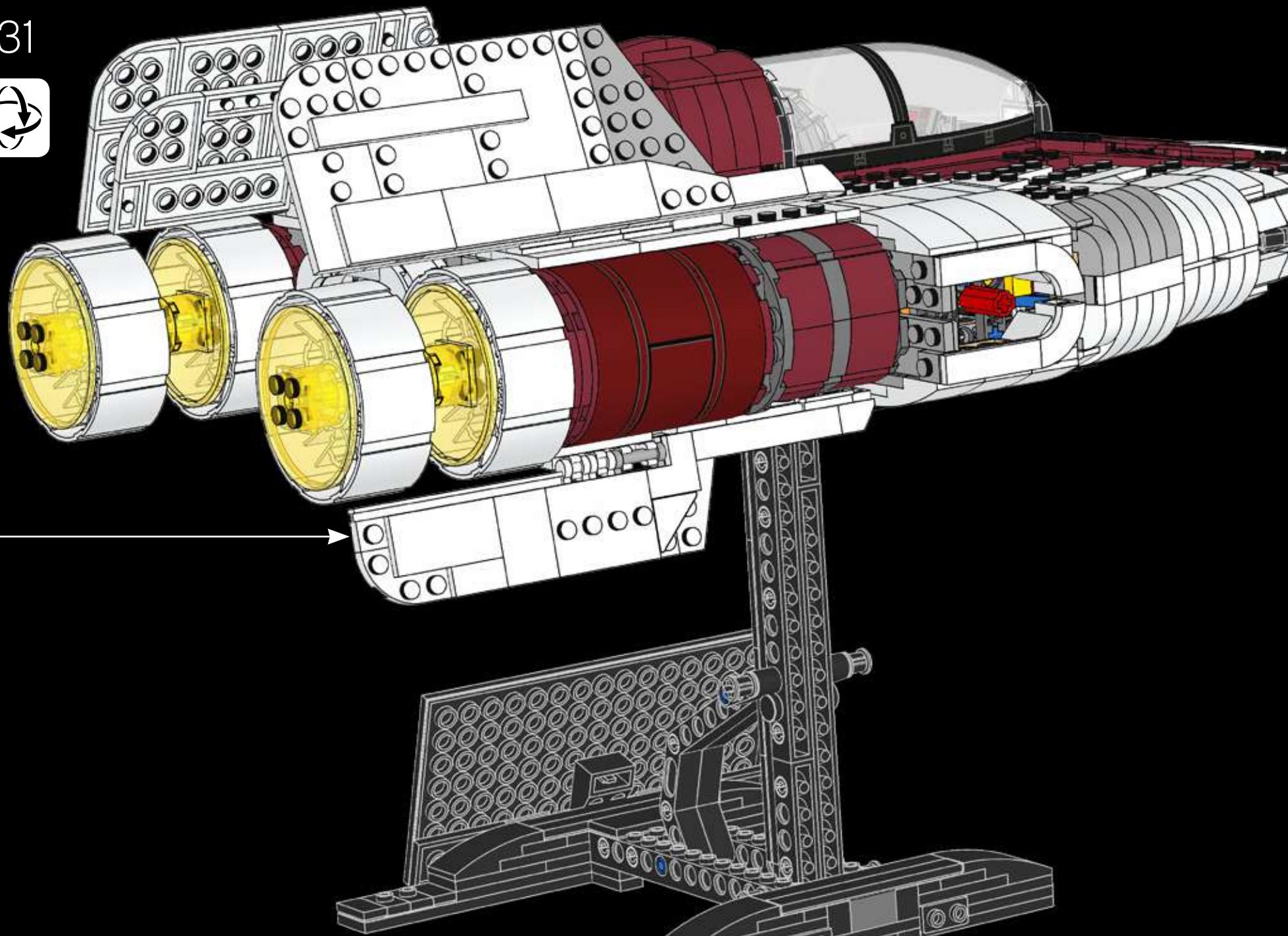

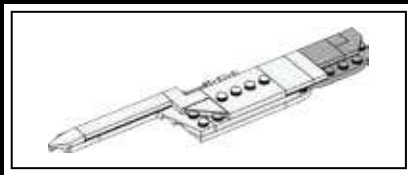

532

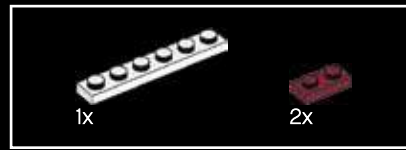

533

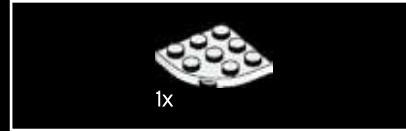

534

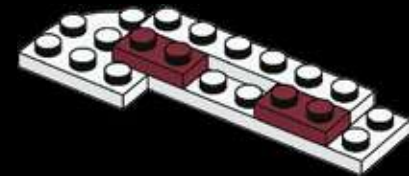

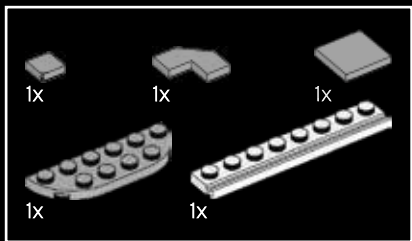

535

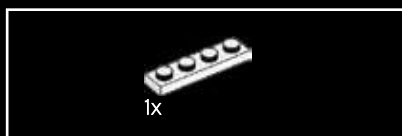
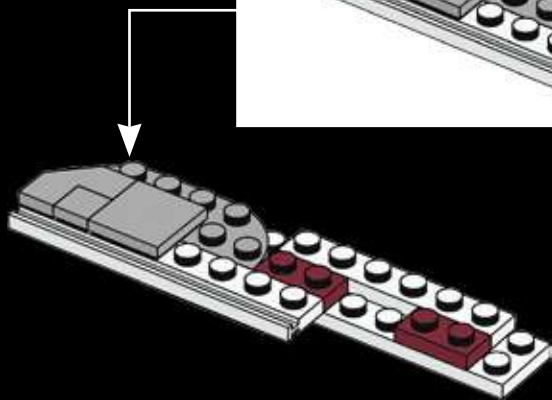
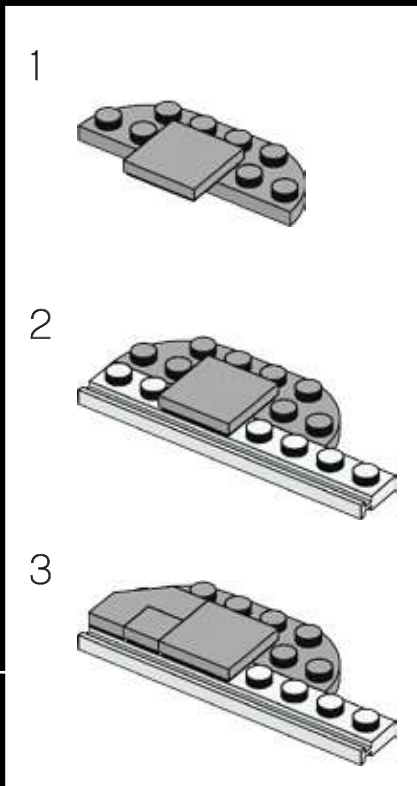

536

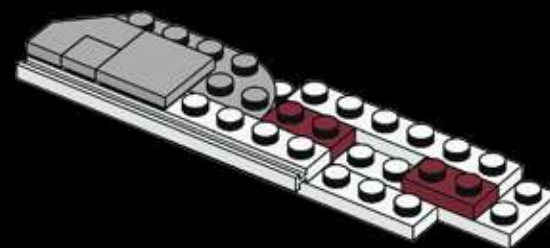

537

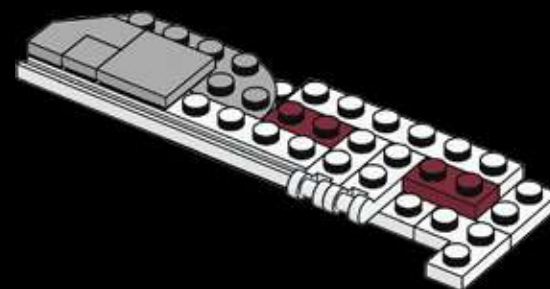





538

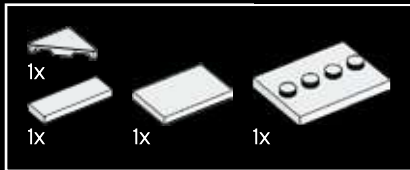
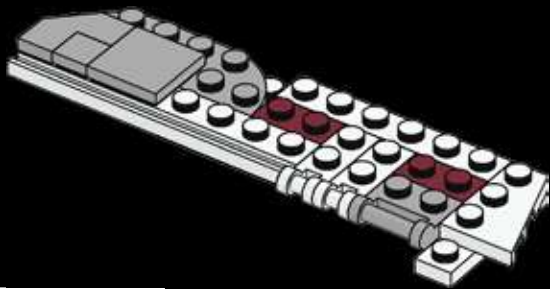

539

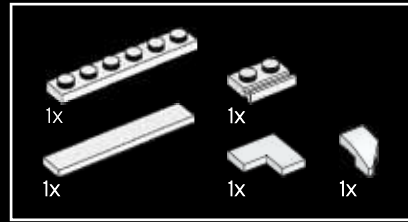
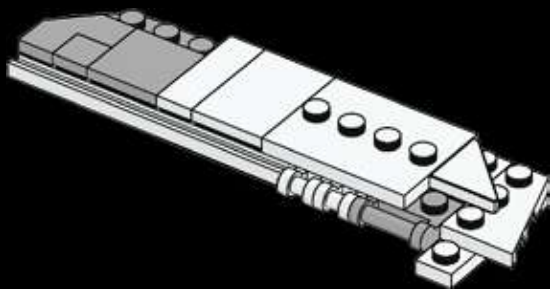

540

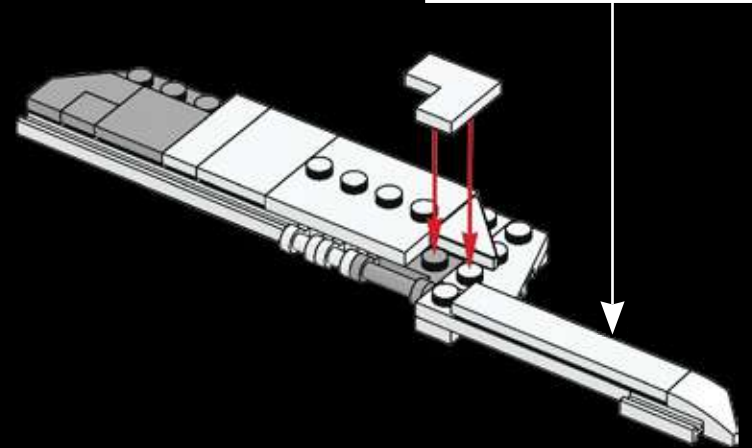
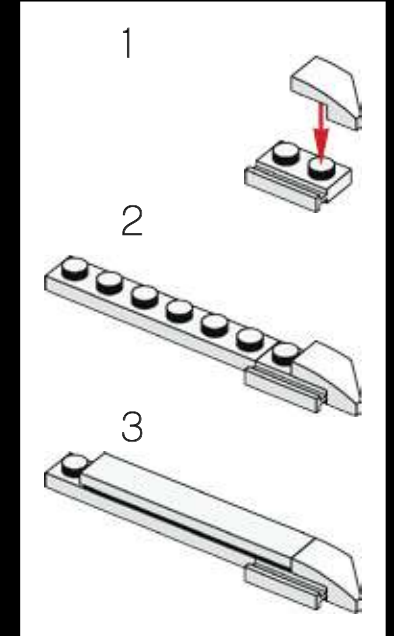



541

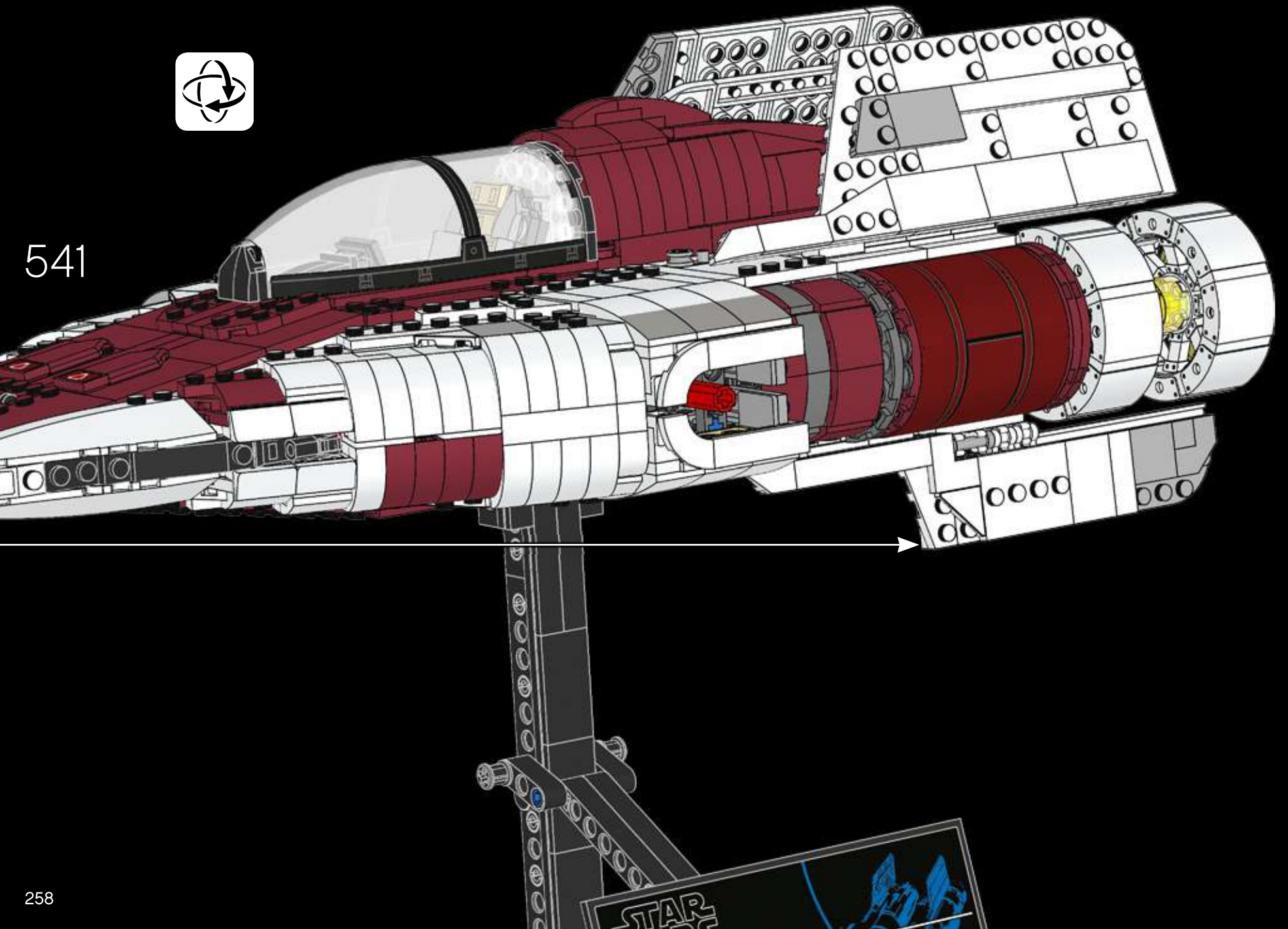



542



543

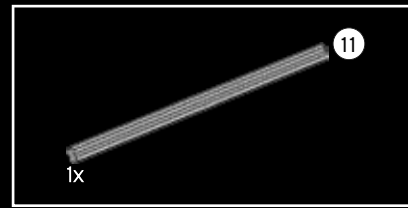
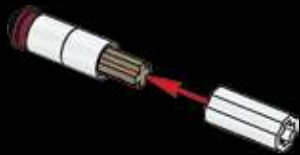

544



545

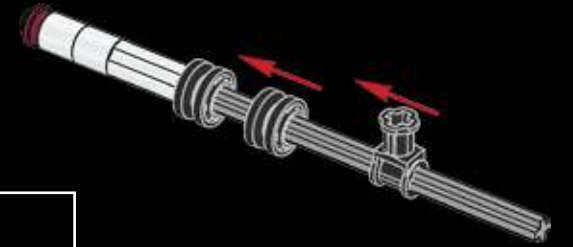

546

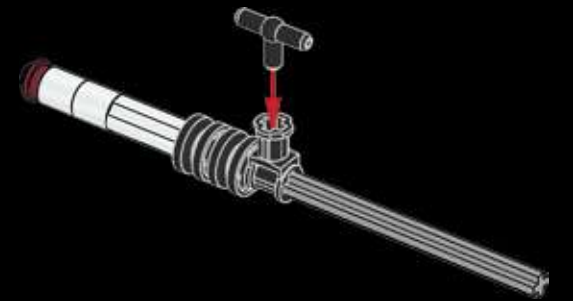



547

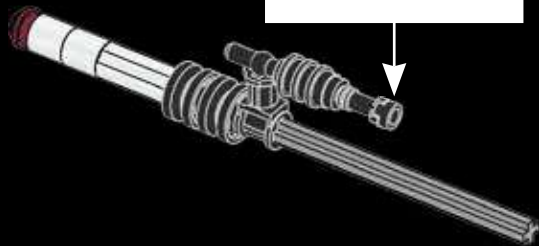
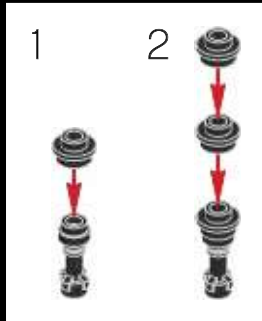

548

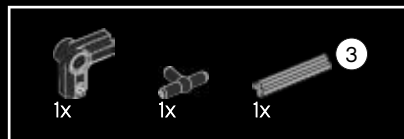
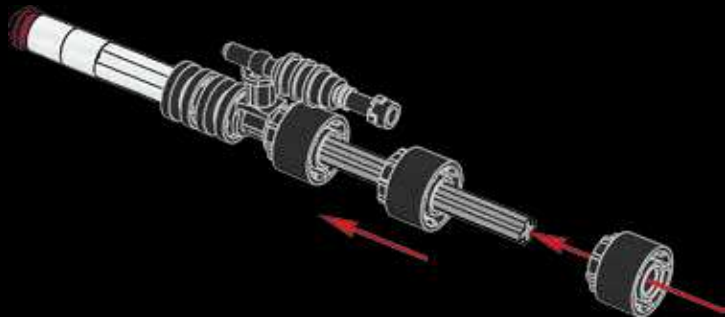

549

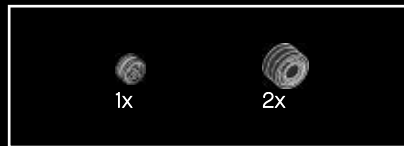
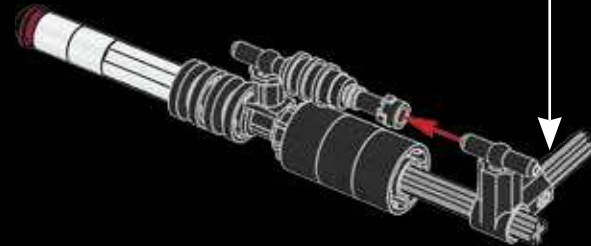
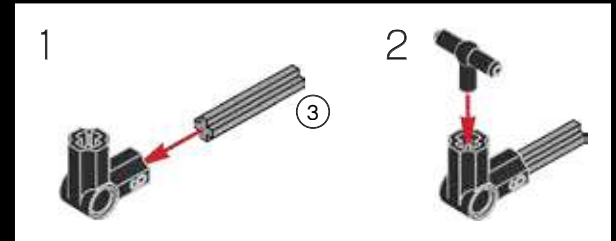

550

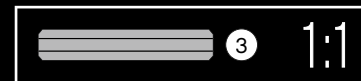
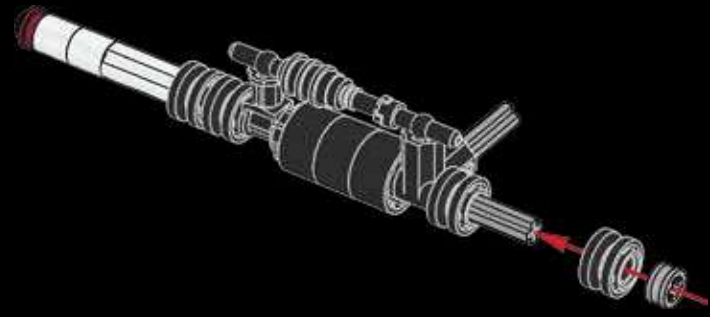



551

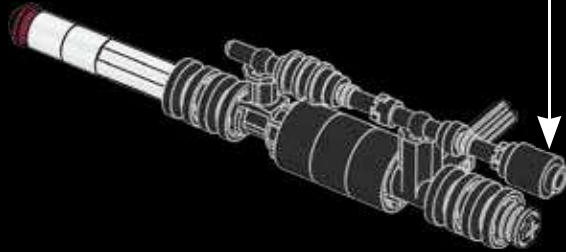

552

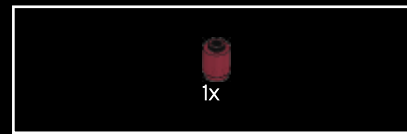
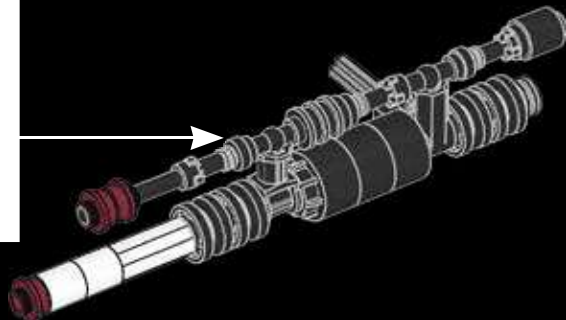

553

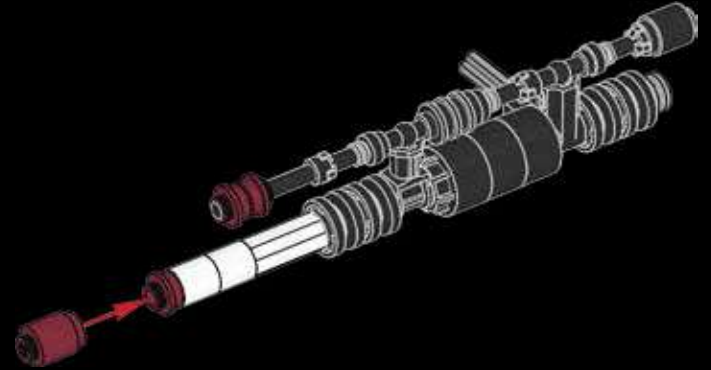

554

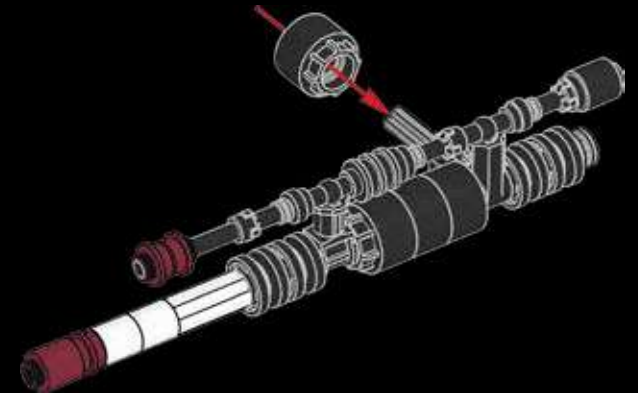

555

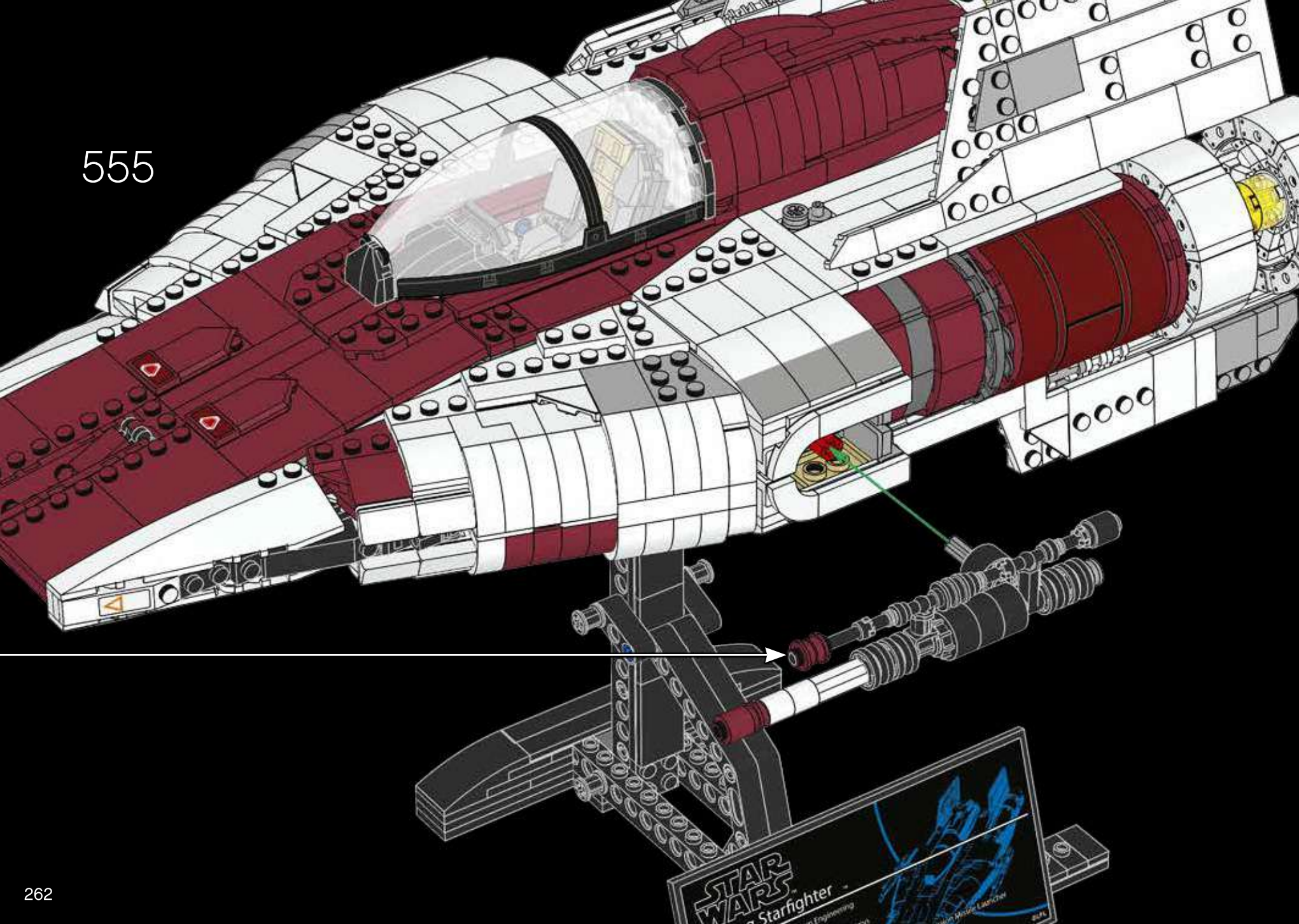



556

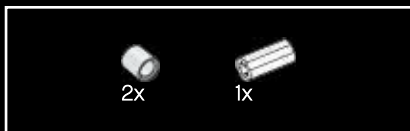

557

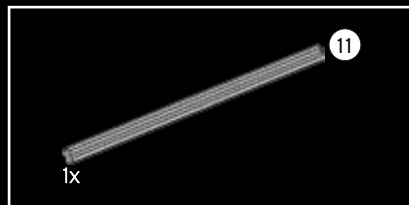
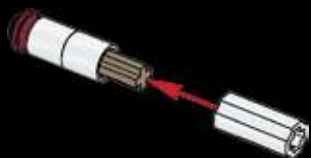

558

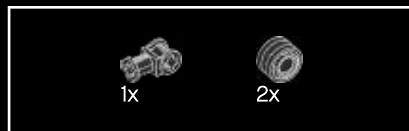

559

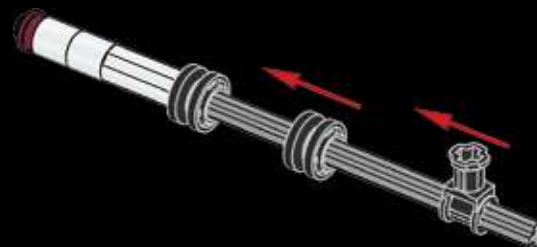



1x

560

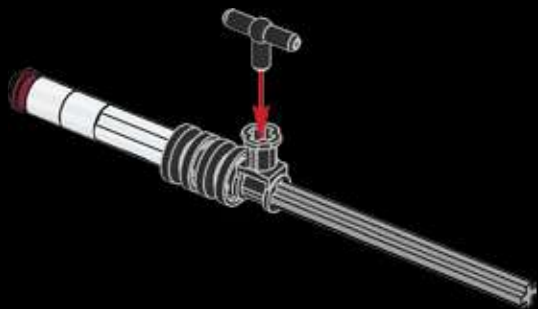

3x

562

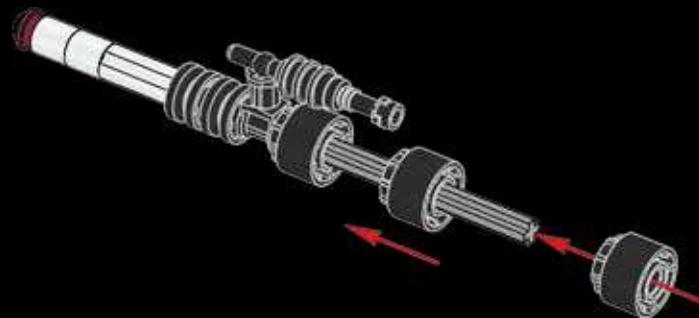

1x



3x

561

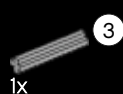
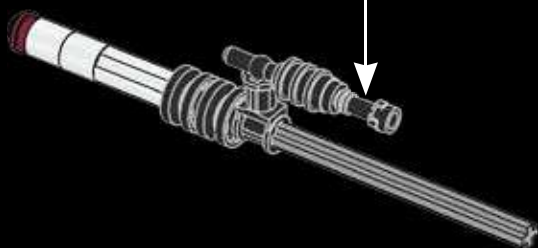
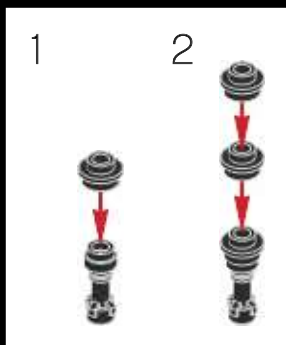

1x



1x



1x

563

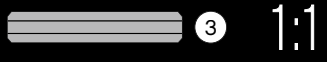
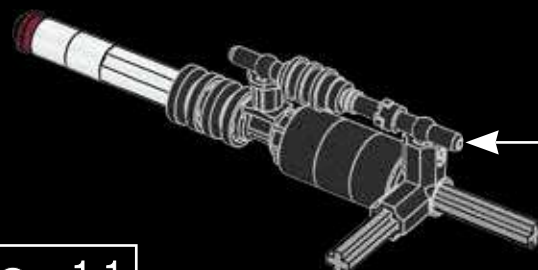
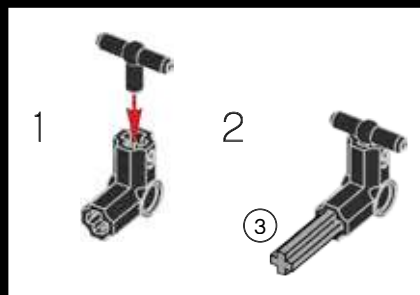





564

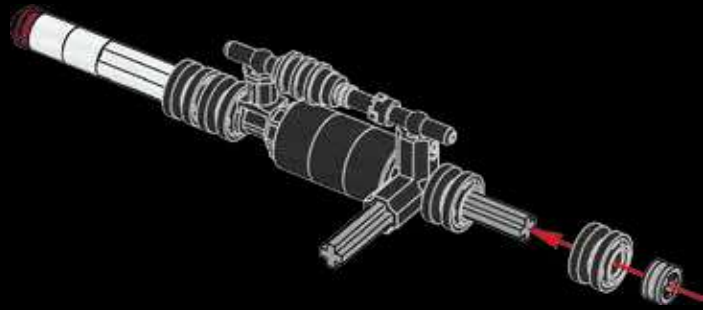

565

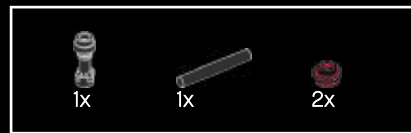
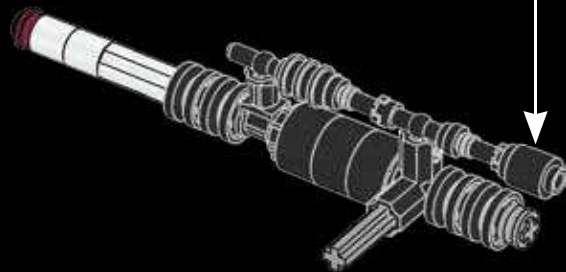

566

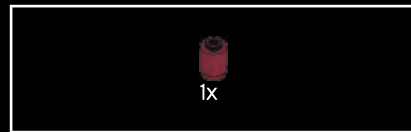
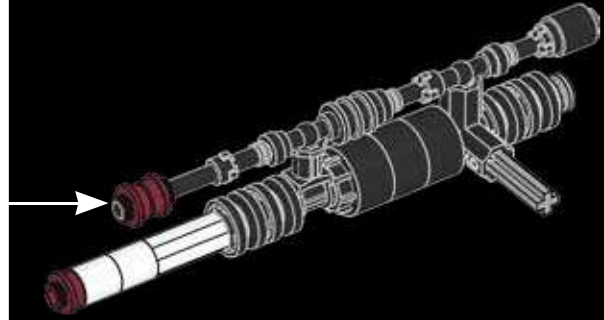

567

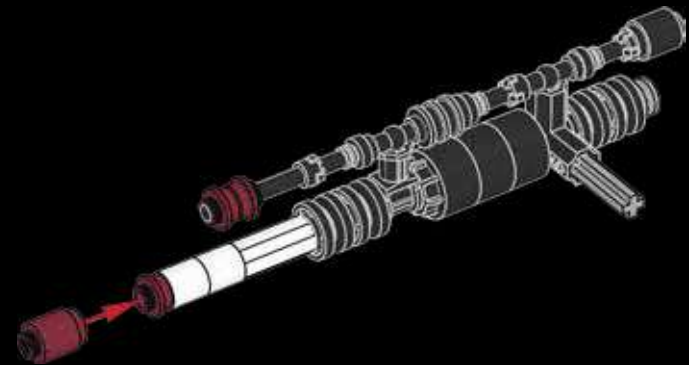

1x

568

569

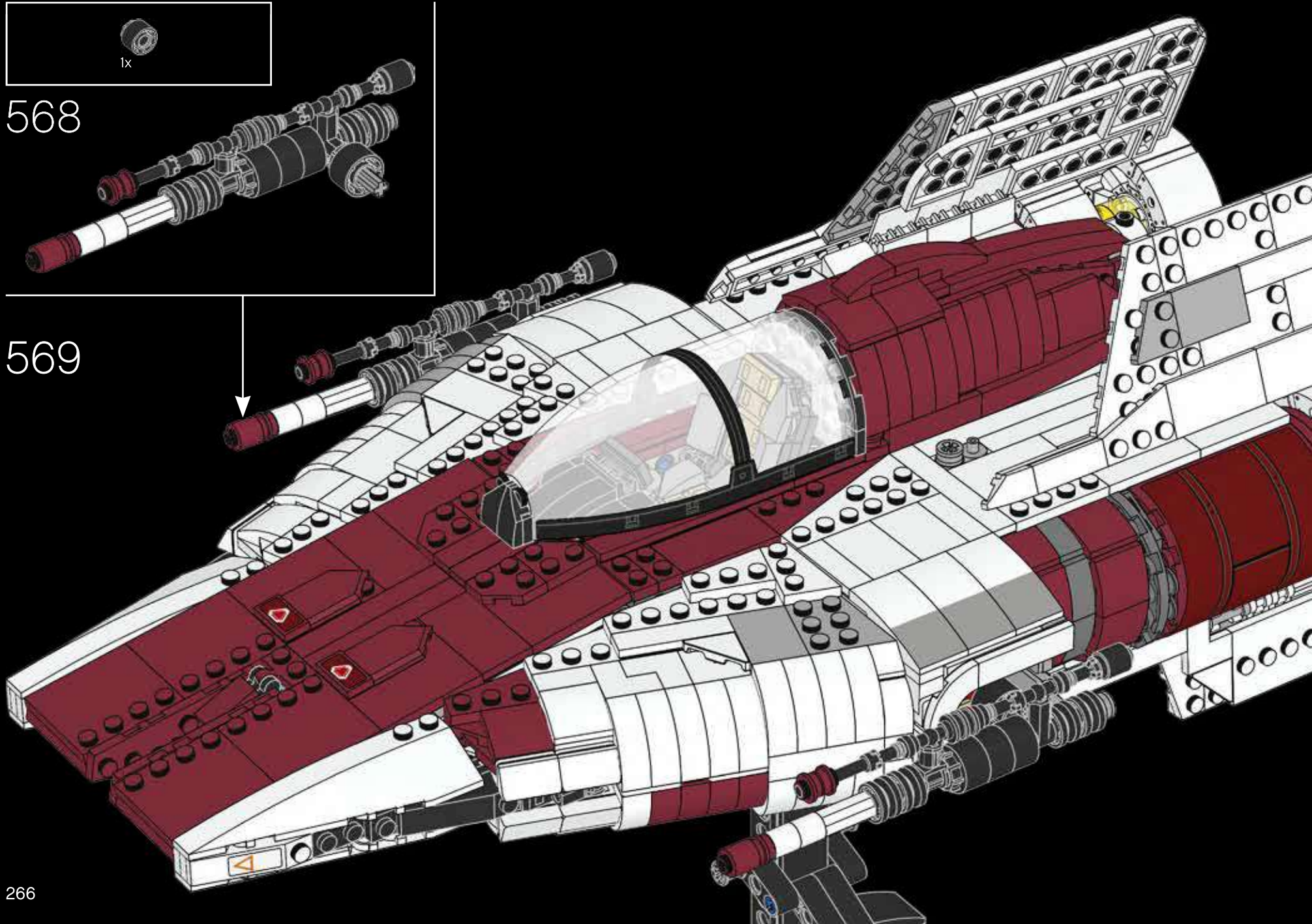

570

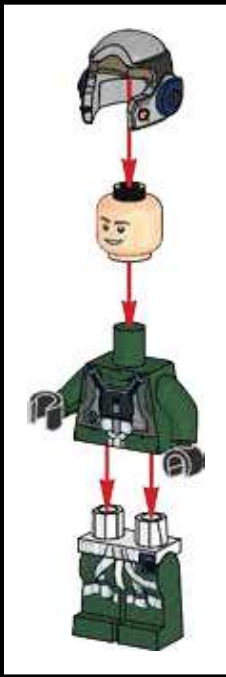
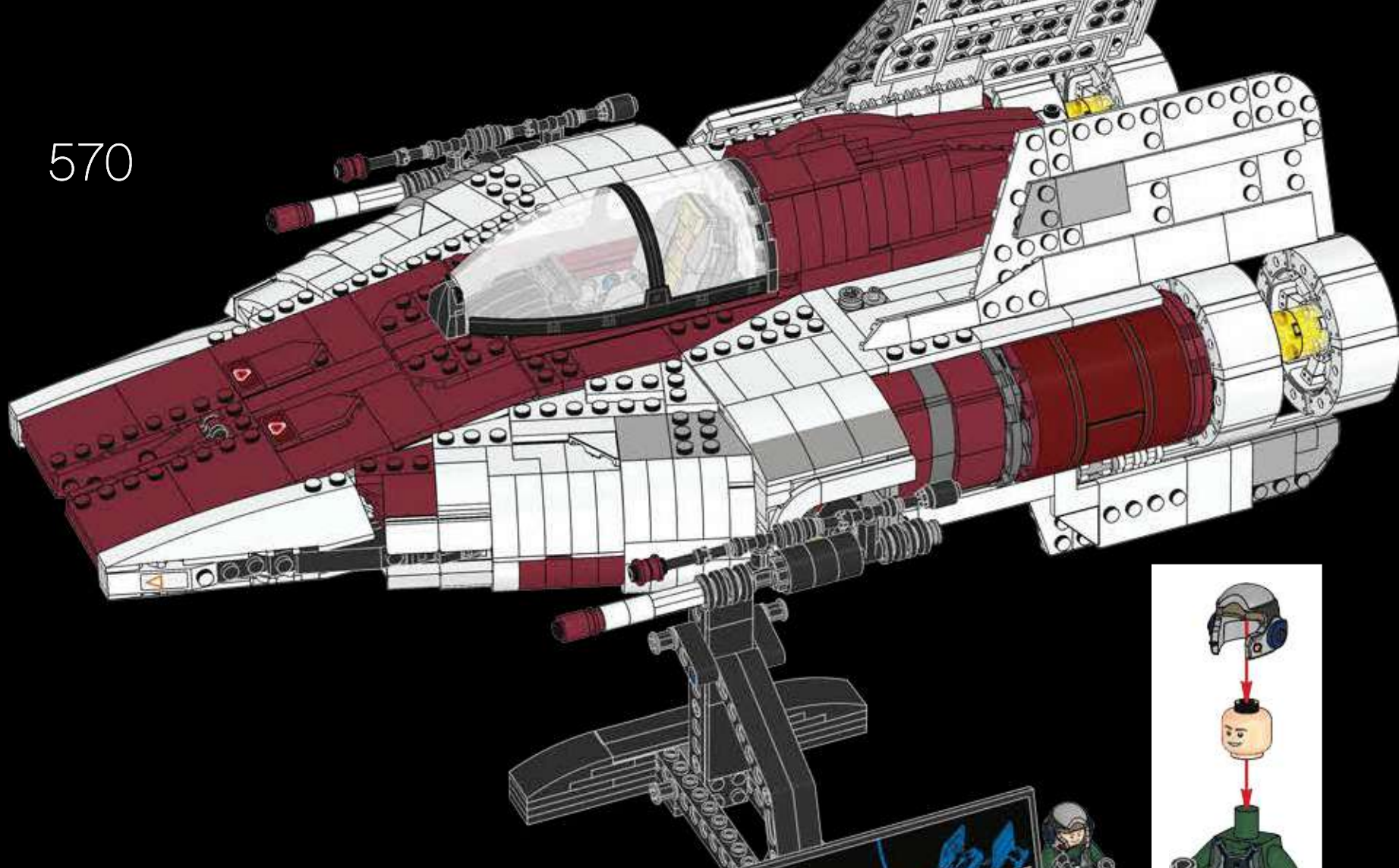

4x 306201  
2x 6168642  
4x 6177114  
1x 302401  
3x 4504369  
8x 6172366  
6x 307001  
2x 6213880  
4x 6242241  
8x 4179875  
2x 6213881  
7x 4179874  
12x 4547489  
6x 6051511  
42x 302301  
6x 306901

6x 393701  
5x 6285777  
7x 6176240  
1x 4247139  
4x 6117940  
8x 6070698  
2x 4249563  
6x 6217875  
7x 4287707  
9x 4287708  
7x 302201  
7x 6047220  
8x 6172674  
7x 242001

4x 4567449  
4x 366001  
9x 6058329  
6x 4612342  
4x 4515364  
2x 362201  
28x 4629913  
4x 362301  
4x 4249112  
9x 4558168  
4x 6168618  
1x 6254603  
12x 302101  
13x 6156667

2x 6294284  
15x 243101  
6x 371001  
2x 4515359  
4x 4599983  
12x 4550745  
3x 6296881  
9x 4560178  
9x 6031947  
8x 6132741  
1x 6147792  
8x 366601  
7x 663601  
1x 300901

2x 6212049  
2x 617901  
11x 379501  
6x 346001  
8x 416201  
6x 4163986  
4x 303201  
4x 6192356  
2x 4501853  
2x 6015477  
2x 6015474

4x 6057799  
8x 4143005  
1x 4160867  
1x 4161330  
2x 403223  
25x 4206482  
2x 302223  
60x 4514553  
2x 370923  
6x 366623  
2x 300121  
1x 366621  
2x 4582843

4x 6284574  
2x 6271820  
2x 654121  
2x 6030266  
2x 6261373  
9x 4142865  
4x 4513174  
2x 6209519  
2x 6129995  
2x 6168644  
2x 6261367  
4x 4188313  
3x 302024  
1x 346024  
2x 6130012

15

4

11

3x 6271167  
2x 4550348  
4x 403224  
2x 6206240  
2x 4107823  
2x 4175441  
8x 6061025  
1x 6130007  
2x 4247771  
1x 623224  
2x 6066102  
6x 4598897  
2x 6321194  
2x 306226  
4x 6284070  
6x 6168646  
8x 6282140

3

3x 393726  
4x 6016172  
2x 6020193  
1x 6093977  
2x 6093525  
6x 302226  
8x 281726  
2x 4124096  
1x 4613759  
2x 6089119  
4x 6315899  
4x 6321745  
1x 6052126  
2x 4142822  
2x 4251161  
2x 366626

8x 4164133  
12x 4253815  
96x 4121715  
8x 6291069  
4x 4107081  
2x 4162857  
2x 6268905  
2x 4598528  
2x 4541191  
3x 300426  
2x 6092585  
4x 370026  
2x 6156991  
13x 302326  
2x 6147050  
4x 306926  
1x 6157554

1x 6296854  
6x 4142236  
1x 374726  
4x 371026  
2x 4515362  
6x 6280168  
4x 4560182  
14x 302026  
4x 4647286  
5x 4142135  
1x 6138405  
4x 389426  
1x 383226  
2x 373726

5

10

2x 307026  
4x 370326  
3x 428226  
1x 4603646  
2x 6181720  
2x 4658977  
3x 379526  
4x 346026  
6x 416226  
1x 6037390  
2x 4645732  
2x 6271152

8x 6291068  
1x 4609050  
4x 6104209  
2x 6181713  
9x 6168645  
2x 4539099  
1x 6219658  
5x 4539114  
2x 6212007  
1x 6219657  
1x 6008595  
1x 6267492

9

1x 6008593  
5x 6210310  
1x 6186001  
1x 6092597  
4x 4539090  
25x 4539097  
4x 4539102  
5x 6173168  
3x 4539068  
2x 4539069  
4x 4585479  
1x 4539105  
23x 6107758  
1x 4585751

1x 4539104  
4x 6028713  
2x 6208727  
2x 6291066  
6x 4583299  
16x 4541546  
4x 4539060  
3x 4539061  
1x 6042953  
4x 6186003  
4x 4539071  
4x 4539062  
2x 4650865

2x 6291067  
8x 6173167  
4x 6208726  
2x 4539083  
2x 6152321  
3x 6037995  
4x 6293875  
2x 6028115  
6x 6186106

1x 6170418  
2x 6258831  
3x 6275844  
6x 4211483  
8x 4211399  
2x 6225139  
1x 4521921  
1x 4211415  
4x 6248078  
2x 4550170  
3x 4211375  
1x 6163478  
2x 6225142  
5x 4568637  
2x 6179186  
1x 6296872

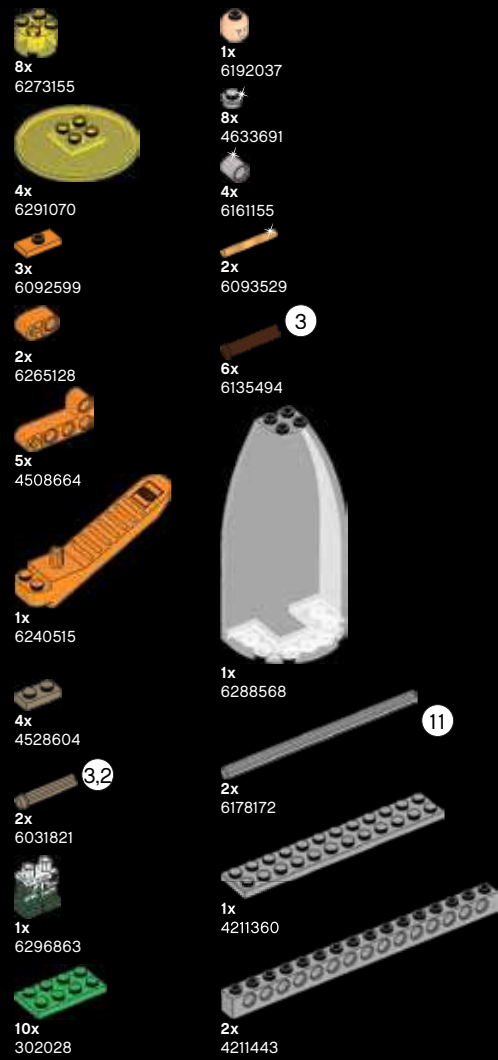

3

11

3,2

**Customer Service**  
**Kundenservice**  
**Service Consommateurs**  
**Servicio Al Consumidor**  
**LEGO.com/service** or dial

00800 5346 5555 :

1-800-422-5346 :

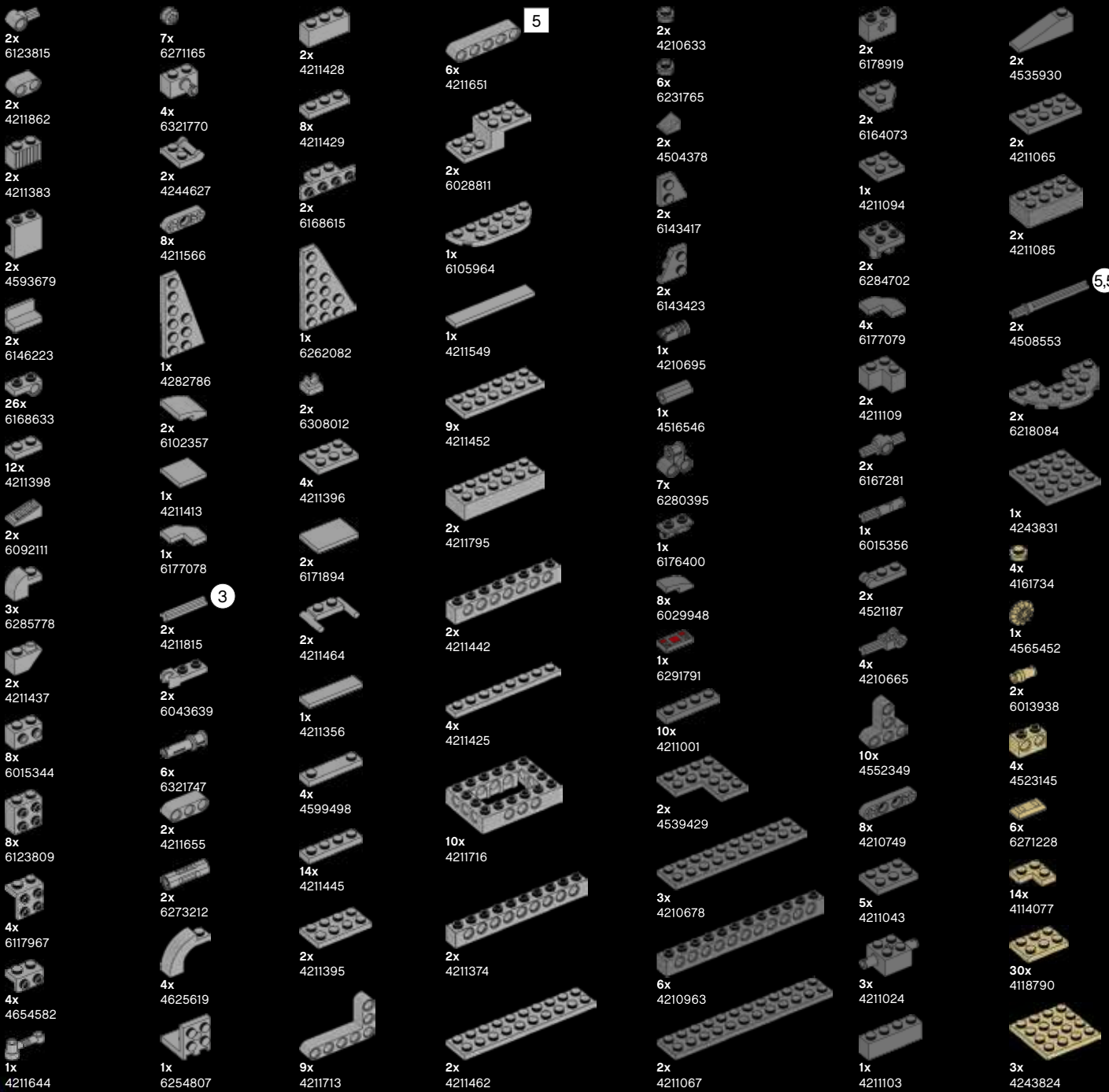

5

3

5.5



# FEEDBACK AND WIN



## FEEDBACK AND WIN

Your feedback will help shape the future development of this product series.

Please visit:

## FEEDBACK UND GEWINNEN

Dein Feedback trägt zur Weiterentwicklung dieser Produktreihe bei.

Geh auf:

## COMMENTEZ ET GAGNEZ

Vos commentaires nous aideront à concevoir les futurs produits de cette gamme.

Rendez-vous sur :

## COMENTA Y GANA

Tu opinión nos ayudará a dar forma al desarrollo de esta serie de productos en el futuro.

Visita:

## 反馈有奖

您的反馈将有助于我们在今后改进本系列产品。

请访问：

---

[LEGO.com/productfeedback](https://www.lego.com/productfeedback)

---

By completing, you will automatically enter a drawing to win a LEGO® set.

Terms & Conditions apply.

Durch Ausfüllen nimmst du automatisch an der Verlosung eines LEGO® Preises teil.

Es gelten die Teilnahmebedingungen.

En envoyant vos commentaires, vous serez automatiquement inscrit(e) à un tirage au sort qui vous permettra de remporter un prix LEGO®.

Offre soumise à conditions.

Al contestar, participarás automáticamente en el sorteo y podrás ganar un set LEGO®.

Sujeto a Términos y Condiciones.

完成我们的反馈调查，即可自动进入抽奖环节，赢取乐高®套装。

适用《条款和条件》。

