



TARGA



PORSCHE



TURBO

Booklet available in English on
Heft in deutscher Sprache erhältlich auf
Livret disponible en français sur
Libretto disponibile in Italiano su
Folleto disponible en español en
如需中文版手册, 请访问

[LEGO.com/service/buildinginstructions](https://www.lego.com/service/buildinginstructions)

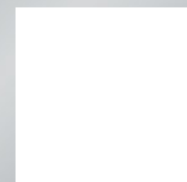



**"In the beginning I looked around
but couldn't find the car I dreamt of,
so I decided to build it myself."**

Dr. Ing. h.c. Ferdinand „Ferry“ Porsche
Founder of the Brand

**„Am Anfang schaute ich mich um,
konnte aber den Wagen, von dem ich träumte, nicht finden.
Also beschloss ich, ihn mir selbst zu bauen.“**

Dr. Ing. h.c. Ferdinand „Ferry“ Porsche
Gründer der Marke

**"It has always been a principle
of our company that function
and beauty are inseparable."**

Ferry Porsche
Founder of the Brand

THE PORSCHE 911

When the Porsche 911 was first introduced at the 1963 Frankfurt Motor Show, it was quickly recognised as a triumph of both design and engineering. Six decades and eight generations later, the concept still endures and the 911 remains one of the most iconic sports cars of all time.

DER PORSCHE 911

Schon bei seinem Debüt auf der IAA in Frankfurt im Jahr 1963 wurde der Porsche 911 als voller Erfolg in puncto Design und Ingenieurskunst gefeiert. Sechs Jahrzehnte und acht Generationen später hat das Konzept immer noch Bestand. Der 911 zählt auch weiterhin zu den legendärsten Sportwagen aller Zeiten.

**„Es war stets ein Leitsatz unseres
Unternehmens, dass Funktion und
Schönheit untrennbar sind.“**

Ferry Porsche
Gründer der Marke



"Nothing even comes close."

Ferdinand Alexander Porsche
Design Lead 911

THE TURBO

The 911 Turbo was first introduced at the German "IAA" Motor Show in Frankfurt in 1973 with the series production version launching a year later at the 1974 Paris Motor Show. Known internally as Type 930, the sports car featured many technical details taken directly from motorsport and was therefore one of the fastest cars of its time.

DER TURBO

Der 911 Turbo wurde 1973 auf der IAA in Frankfurt vorgestellt, das Serienmodell feierte dann ein Jahr später auf dem Pariser Autosalon seine Weltpremiere. In den intern als Typ 930 bezeichneten Sportwagen wurden zahlreiche technische Details direkt aus dem Motorsport übernommen, was ihn zu einem der schnellsten Autos seiner Zeit machte.

„Nichts kommt ihm auch nur nahe.“

Ferdinand Alexander Porsche
Verantwortlich für das Design des 911





THE TARGA

Responding to increased safety requirements for open top cars in the US, Porsche designed the world's first safety cabriolet with a fixed roll-over bar. The first 911 Targa was introduced in 1965. The name itself came from the Targa Florio road race in Sicily where Porsche had enjoyed great motorsport success since the mid 1950s.

DER TARGA

Als Reaktion auf die verschärften Sicherheitsvorschriften für Cabriolet Modelle in den USA, entwickelte Porsche sein erstes offenes Modell mit fest montiertem Überrollbügel. Der erste 911 Targa wurde 1965 vorgestellt. Der Name selbst geht auf das Straßenrennen Targa Florio in Sizilien zurück, bei dem Porsche seit Mitte der 1950er-Jahre große Motorsportserfolge feiern konnte.

**"Design is not simply art,
it is elegance of function."**

F.A. Porsche
Design Lead 911

**„Design ist nicht einfach Kunst,
es ist die Eleganz der Funktion.“**

F.A. Porsche
Verantwortlich für das Design des 911

FROM THE DESIGN TEAM

This model started out as a passion project of mine. Naturally, I'm very excited that we decided to make it into an actual LEGO® set. I began by reading all about the different Porsche 911 versions and gathered lots of images of the car to work from. The major challenge was designing the model so it could be built as either a Turbo or a Targa. We built five different versions of the car before we were happy with the result. I'm especially proud of how well we managed to capture the "face" of this car; the front bumper and the angled headlights, etc. It's classic 911!

ANMERKUNGEN DES DESIGNTREAMS

Das Modell begann als meine absolute Herzenssache. Natürlich freut mich unsere Entscheidung, daraus tatsächlich ein LEGO® Set zu machen. Zunächst las ich alles über die verschiedenen Versionen des Porsche 911 und sammelte jede Menge Bilder des Autos als Arbeitsgrundlage. Die größte Herausforderung bestand darin, das Modell so zu gestalten, dass es sich entweder als Turbo oder als Targa bauen lässt. Zufrieden waren wir erst nach der fünften Version des Autos. Ich bin besonders stolz darauf, wie gut wir das „Gesicht“ dieses Wagens – unter anderem die Frontstoßstange und die abgeschrägten Scheinwerfer – hinbekommen haben. Ein klassischer 911!



Mike Psiaki
LEGO® Design Master

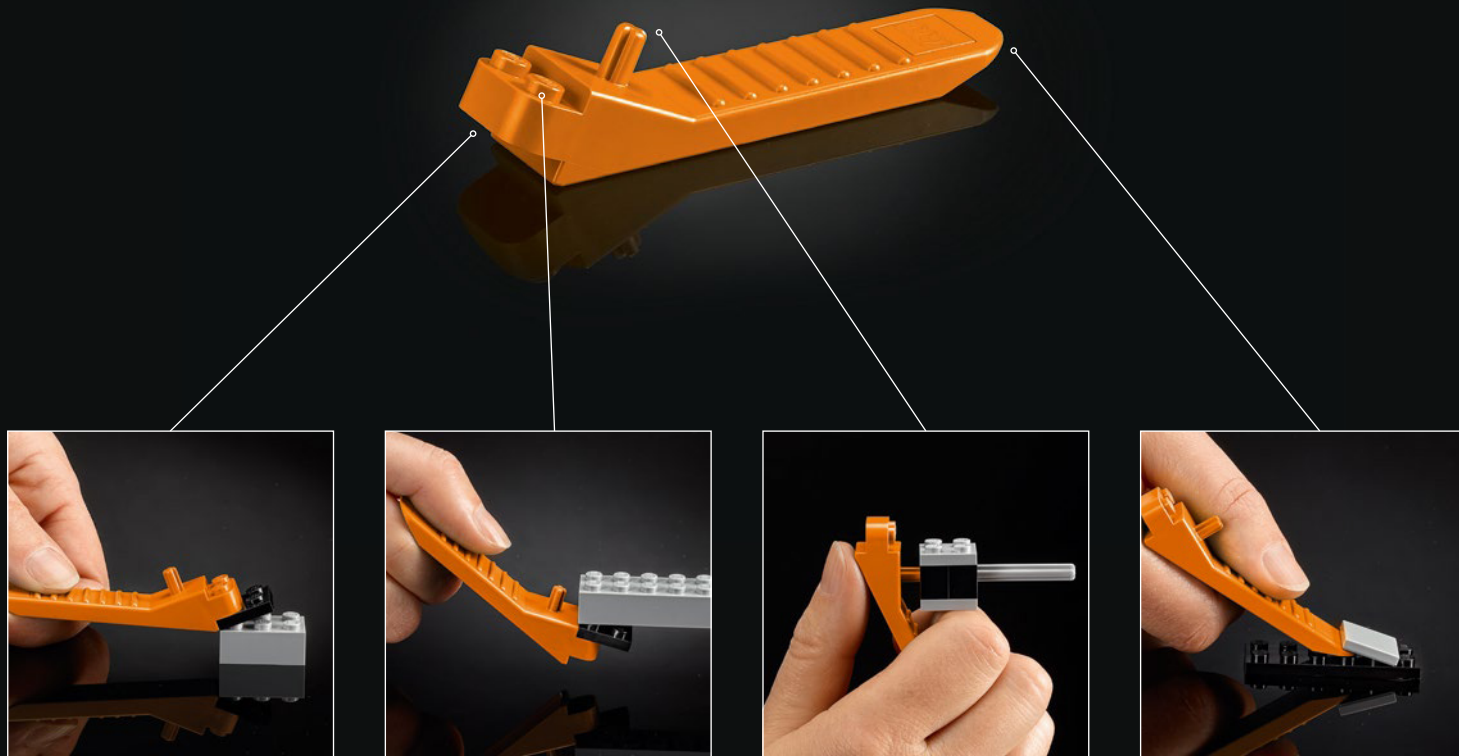

[LEGO.com/brickseparator](https://www.lego.com/brickseparator)

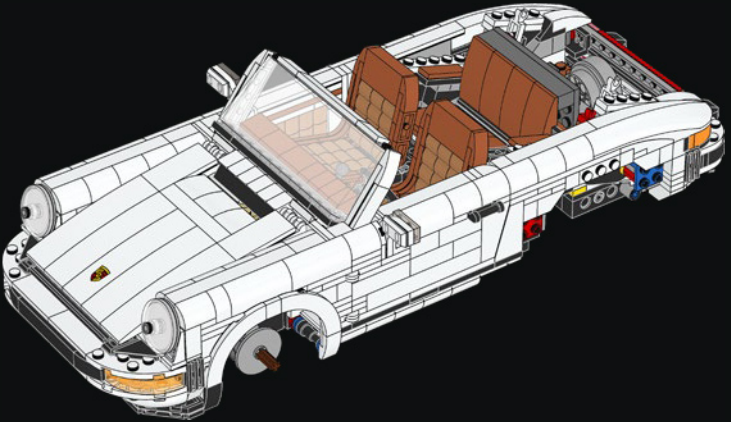

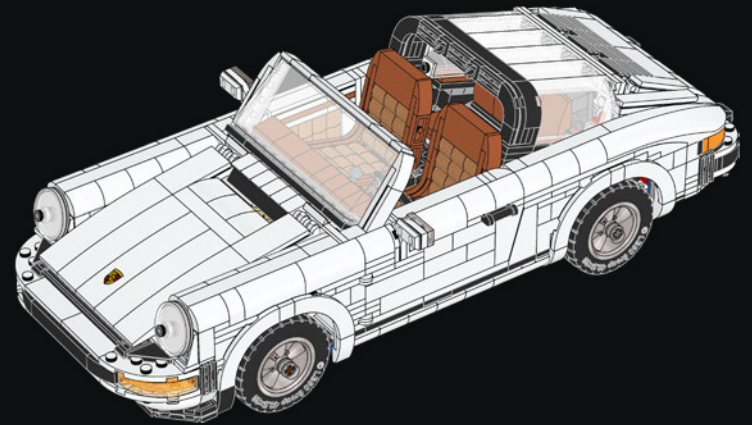
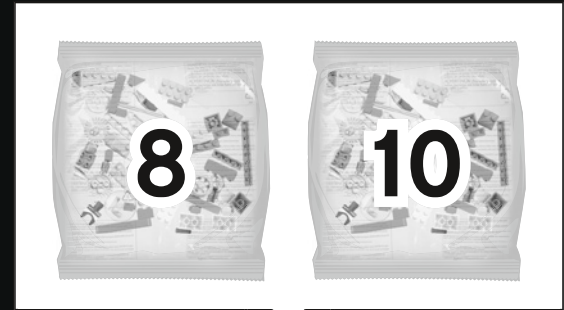
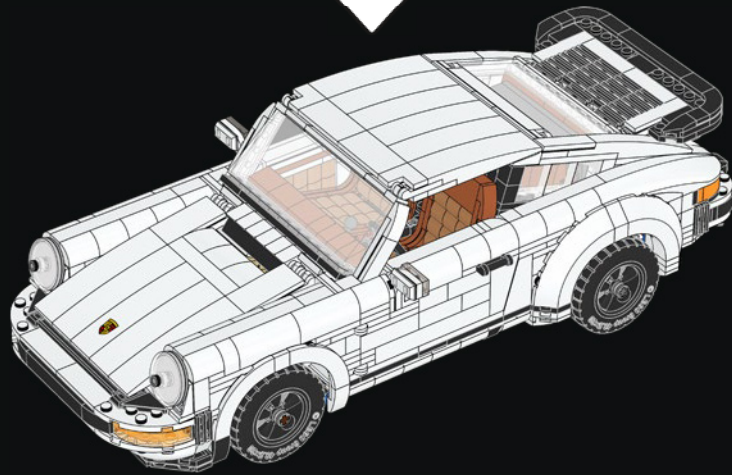

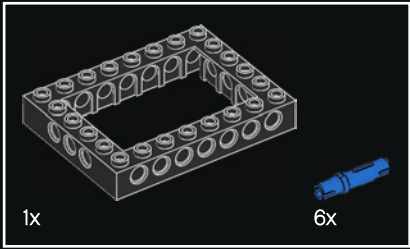
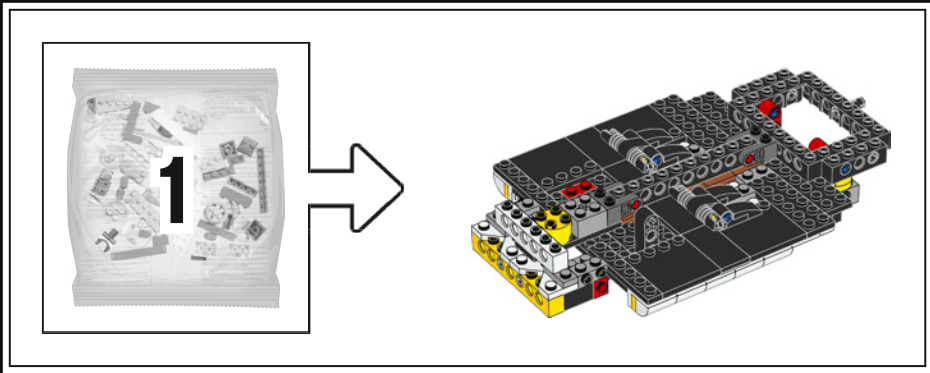

1

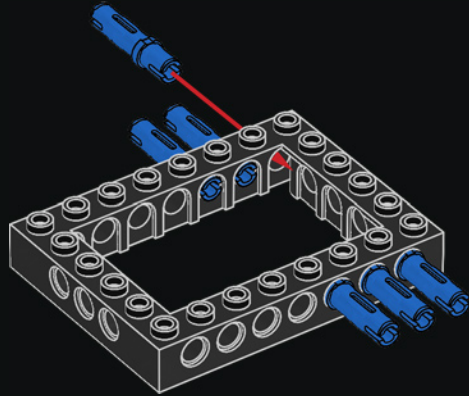

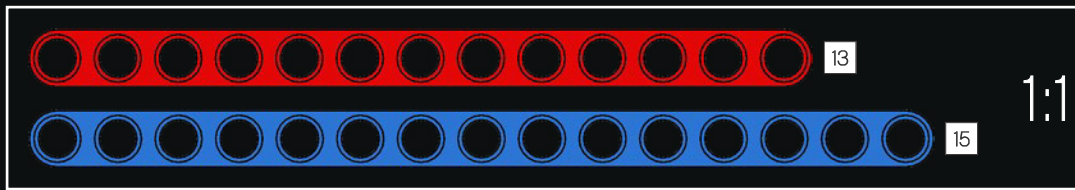
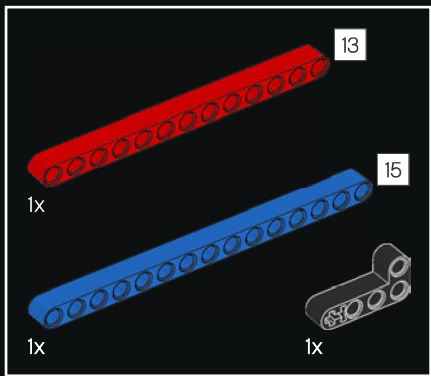

2

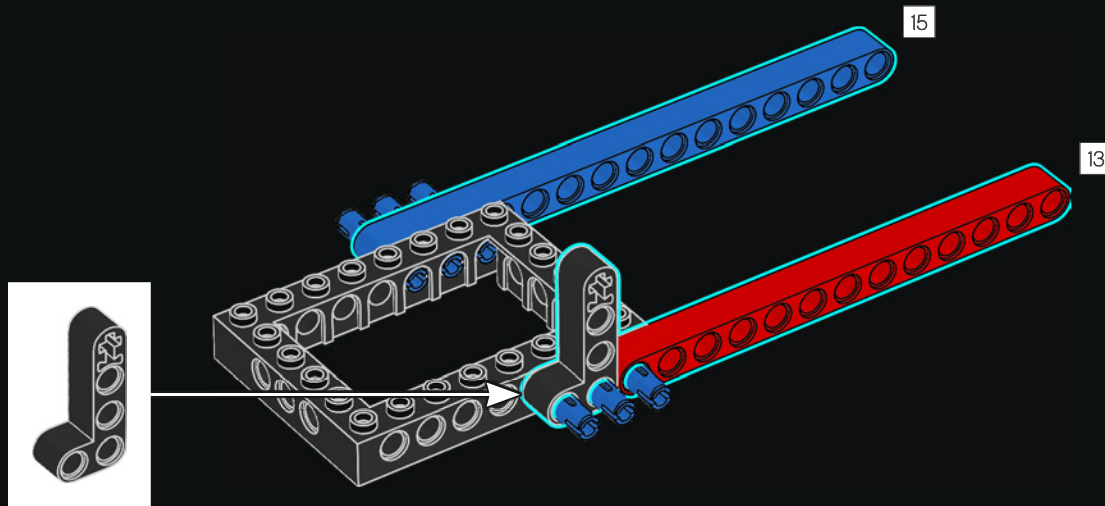

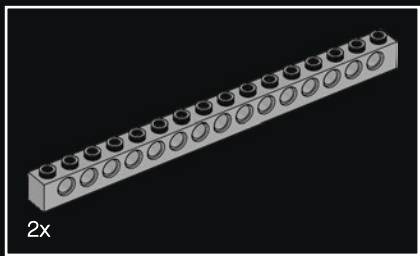

3

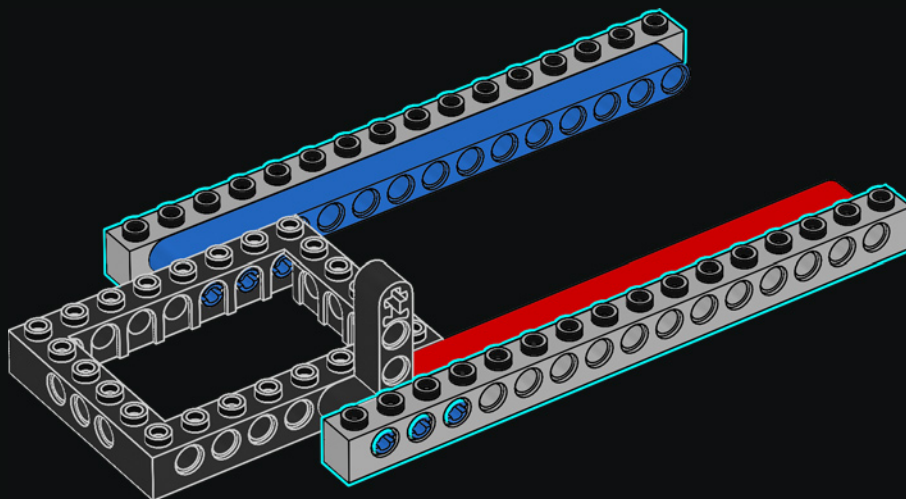

4

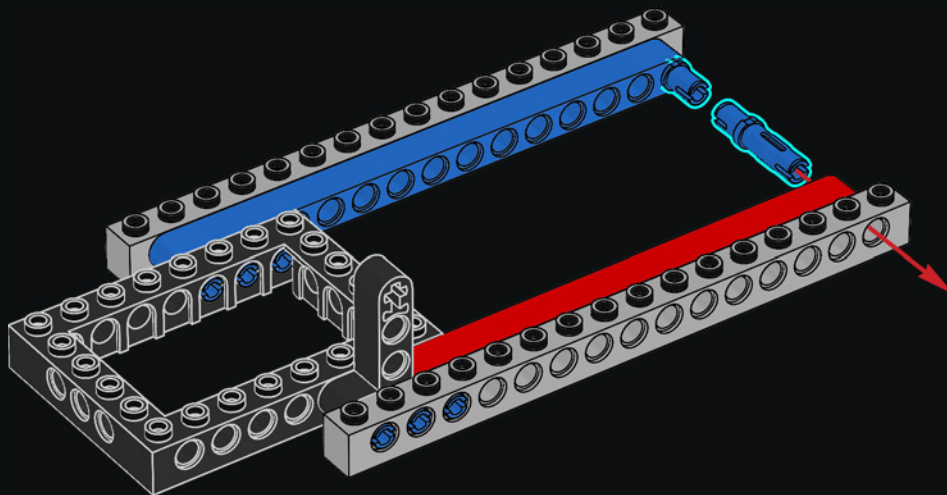



5

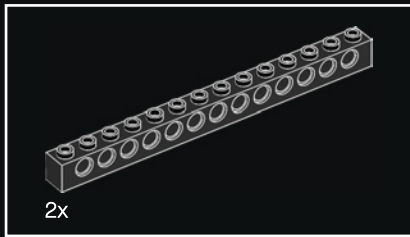
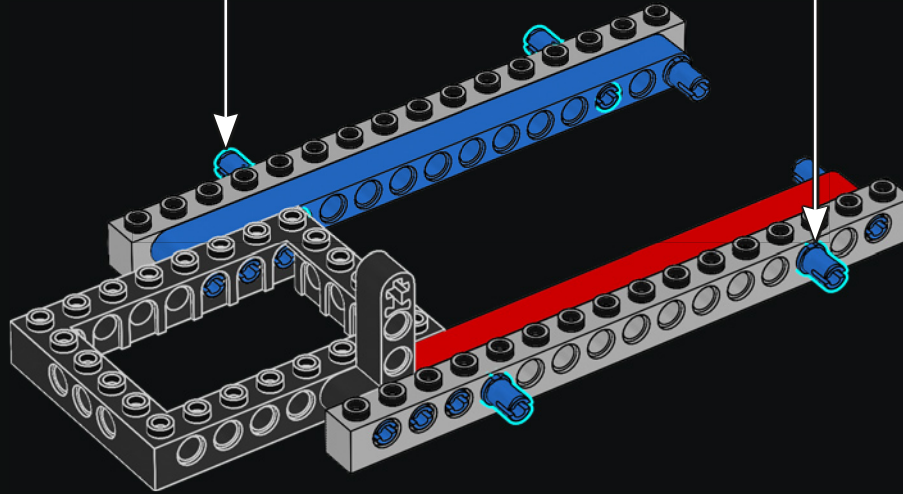
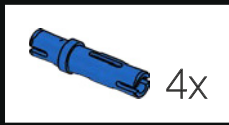

6

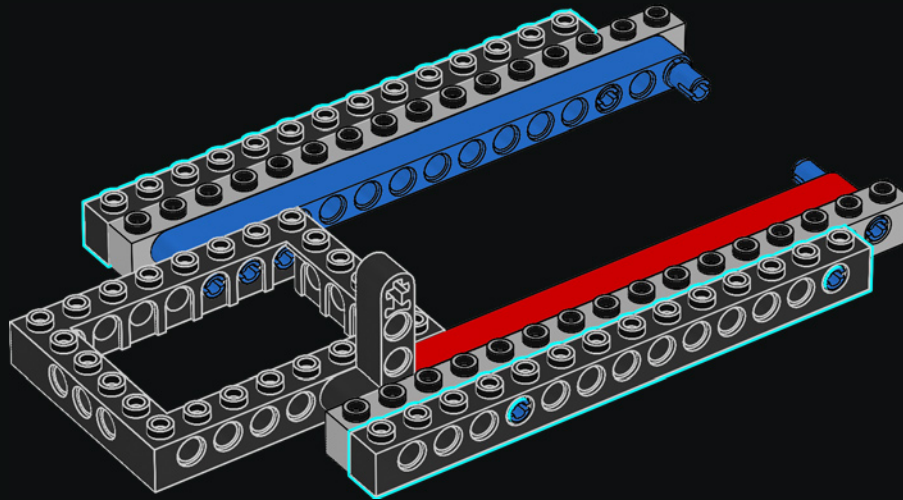



2x

7

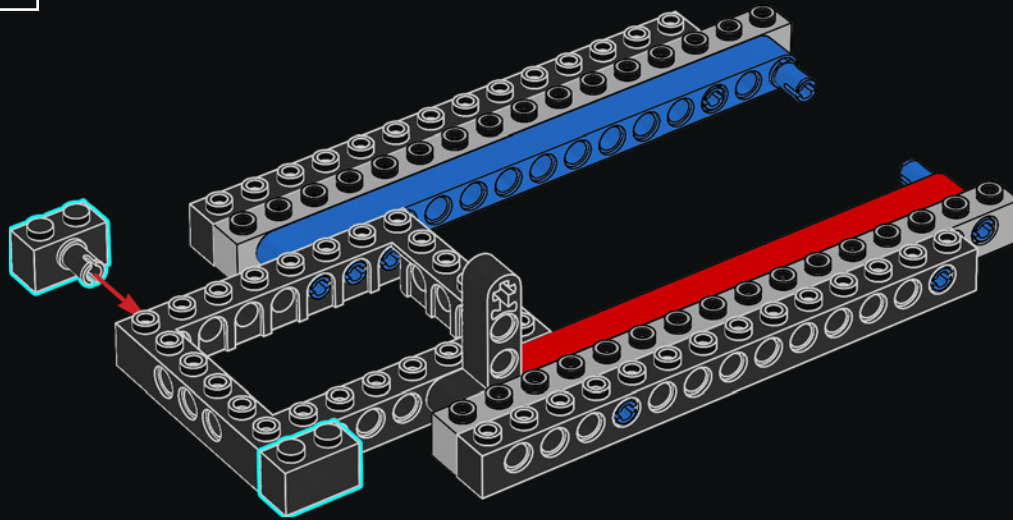

1x



2x

8

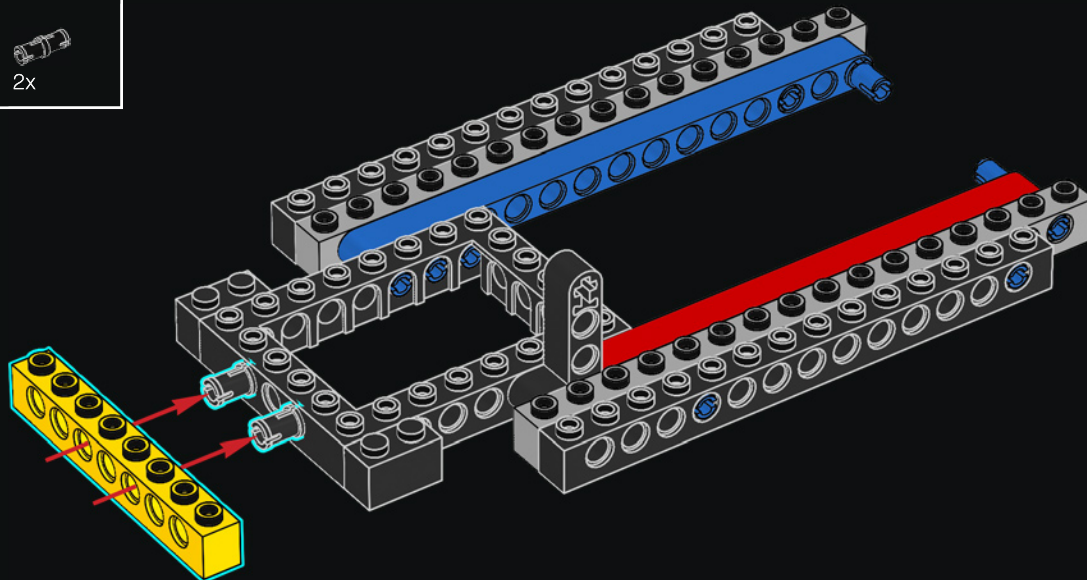



9

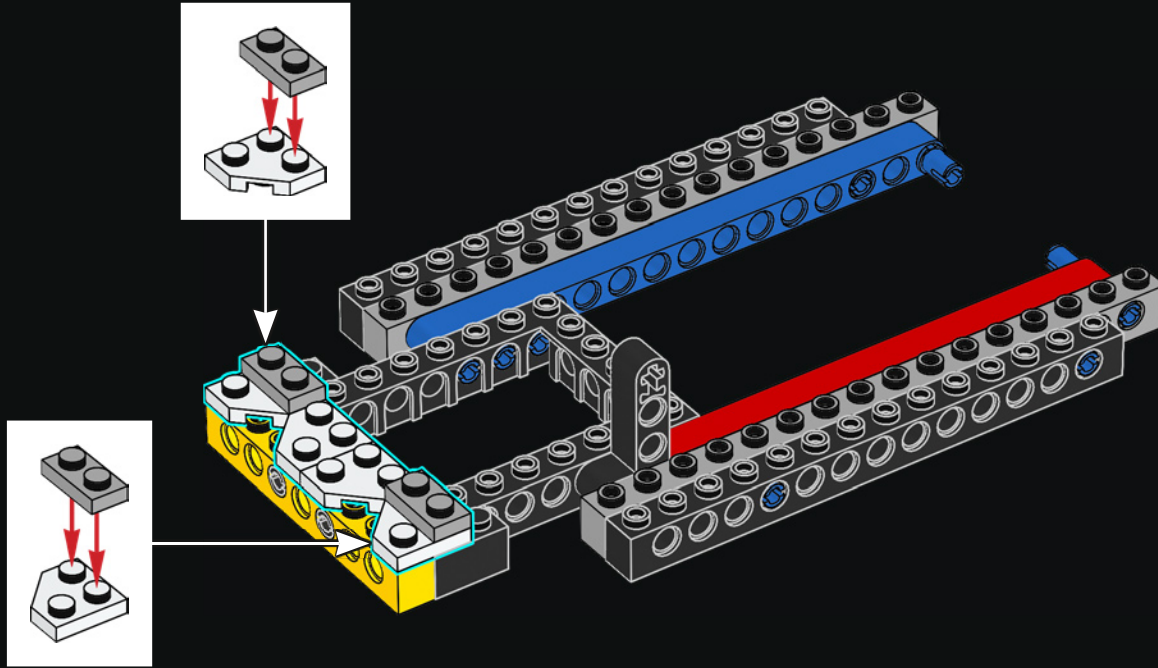



10

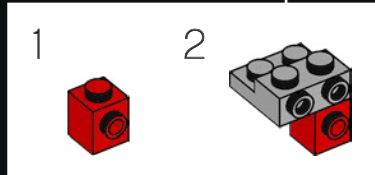
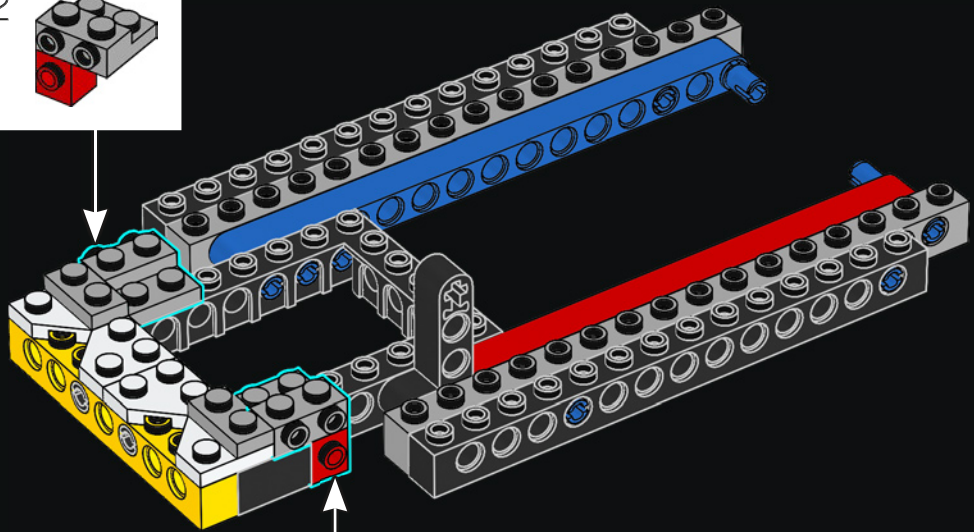
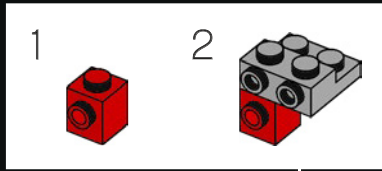

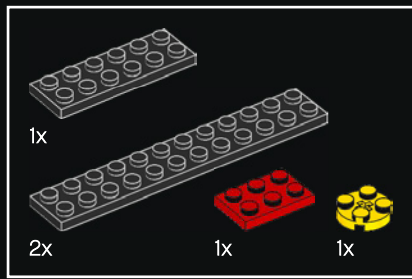

11

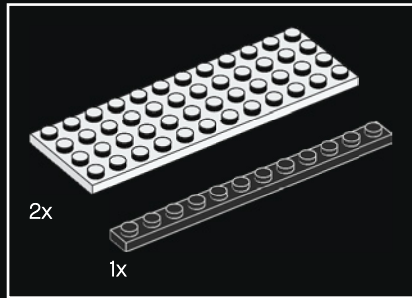
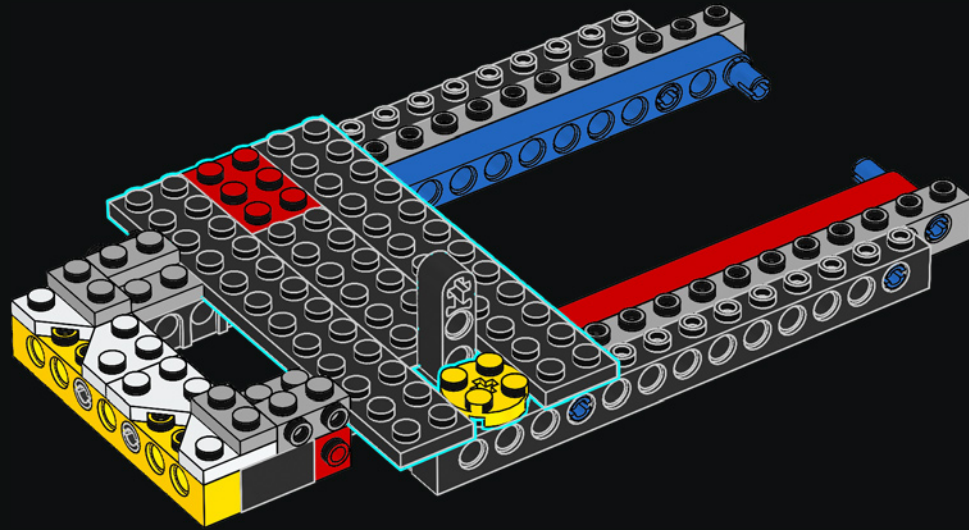

12

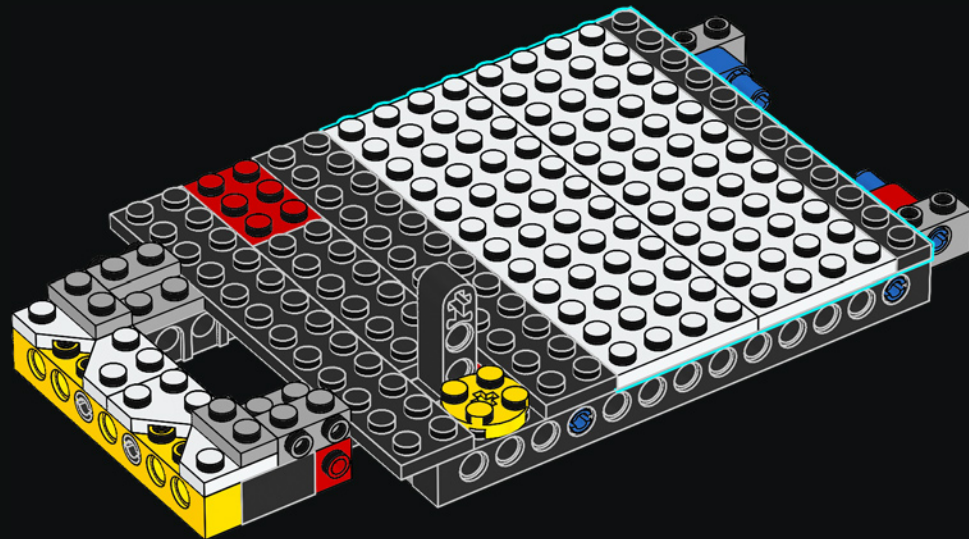

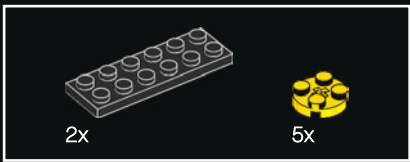

13

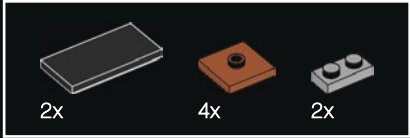
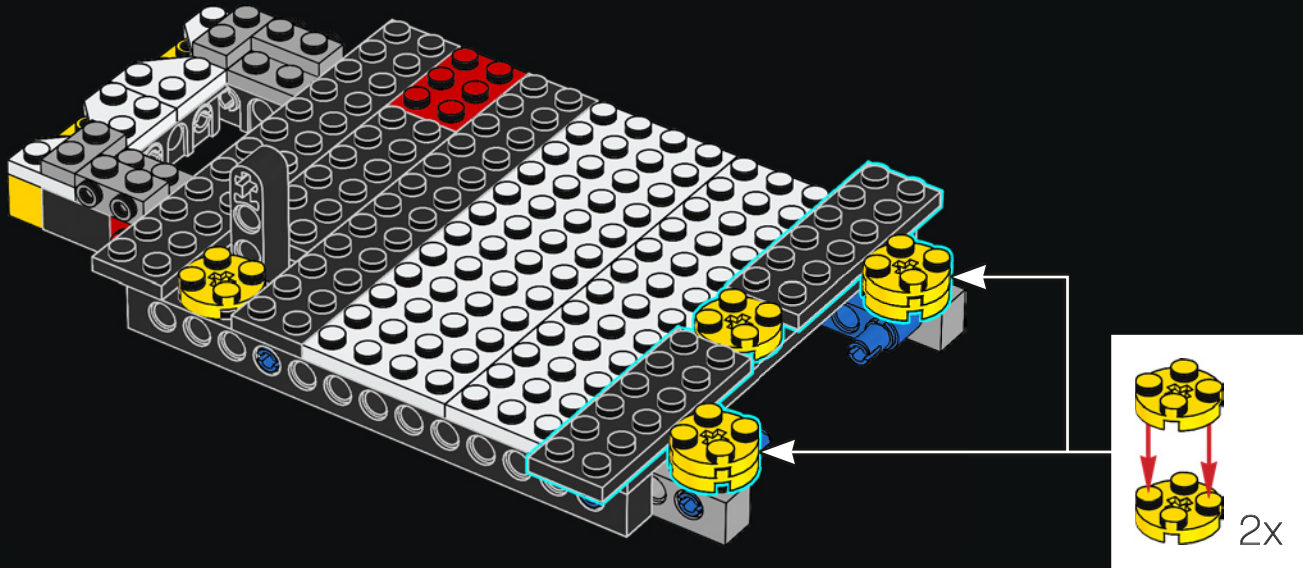

14

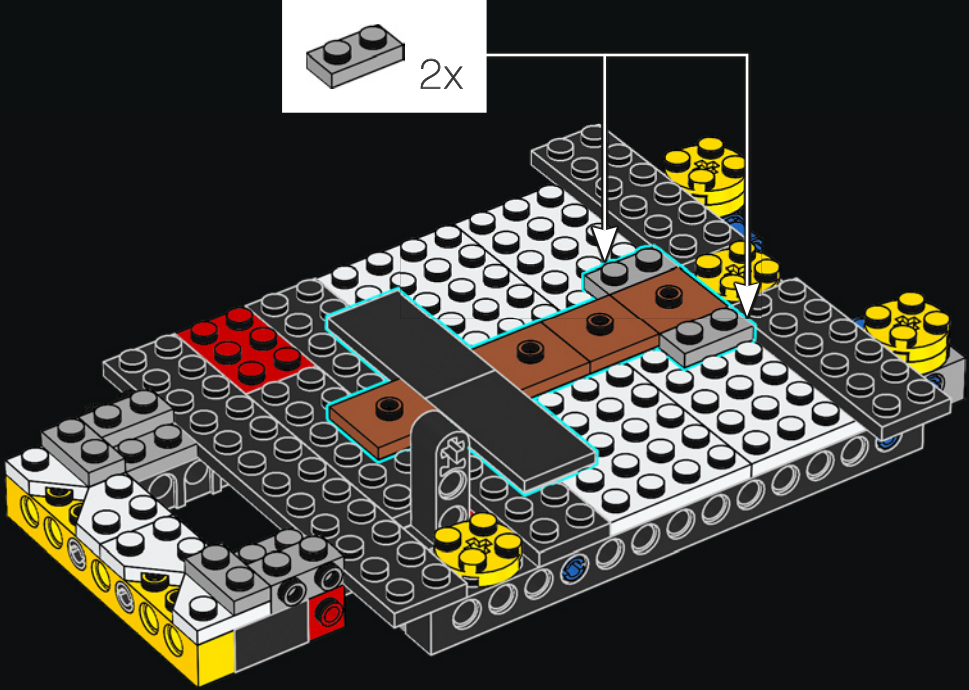

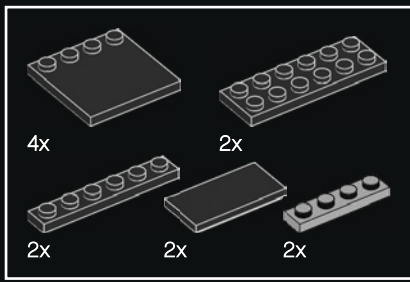

15

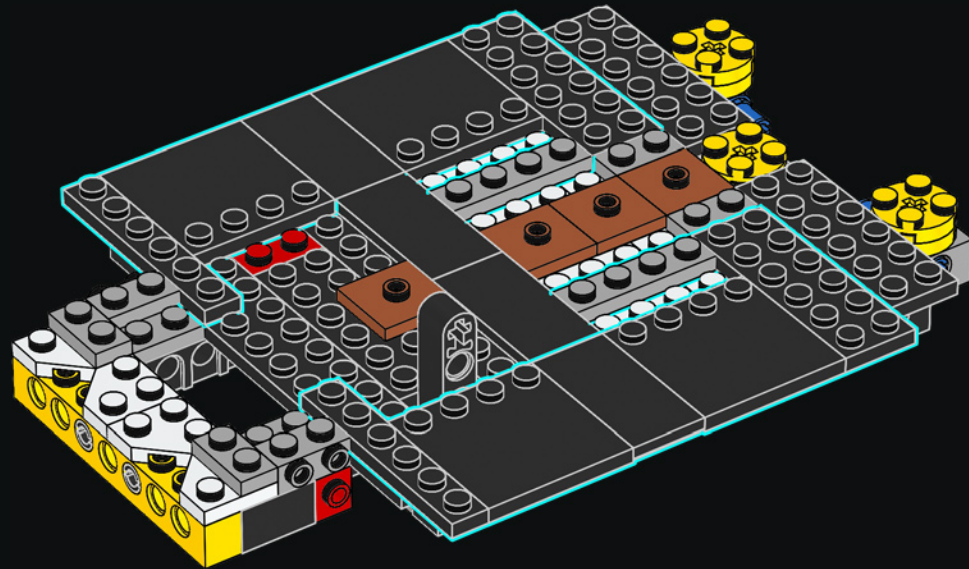

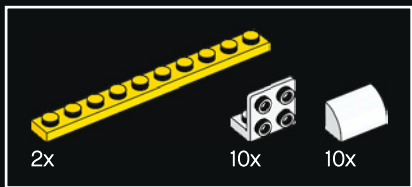

16

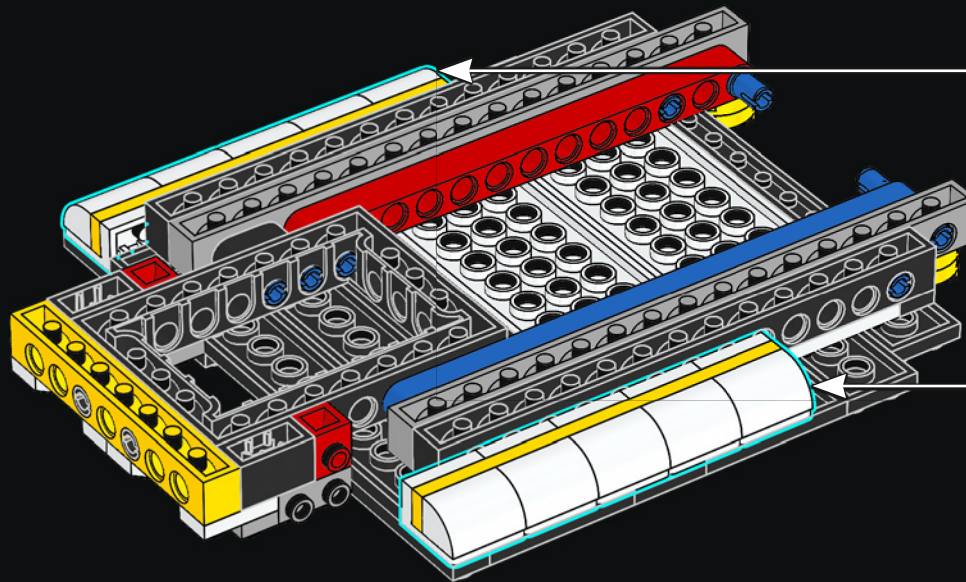
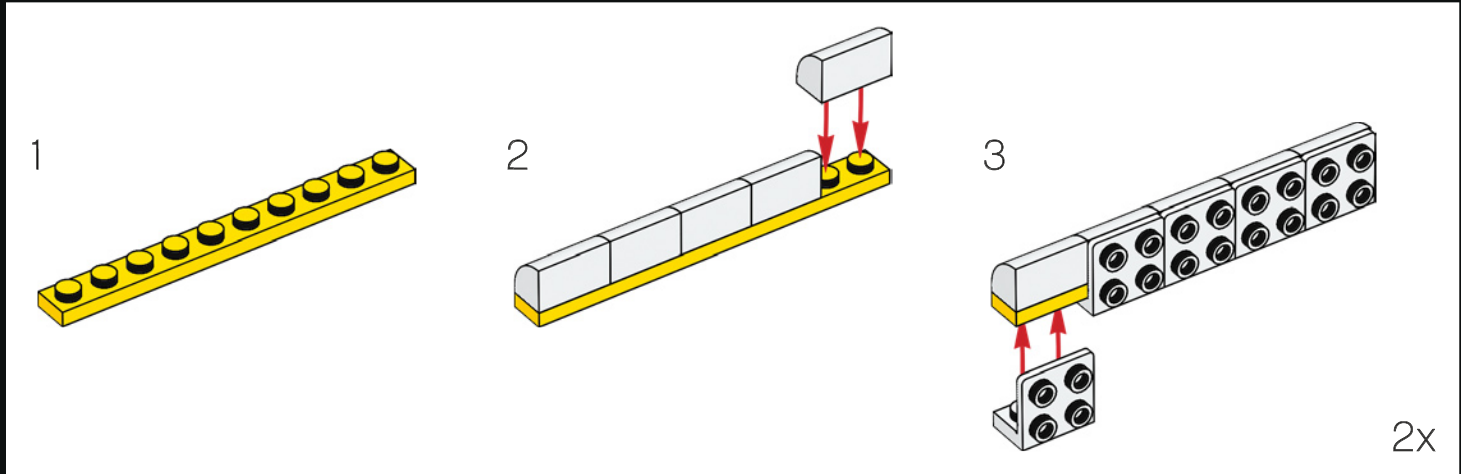



17

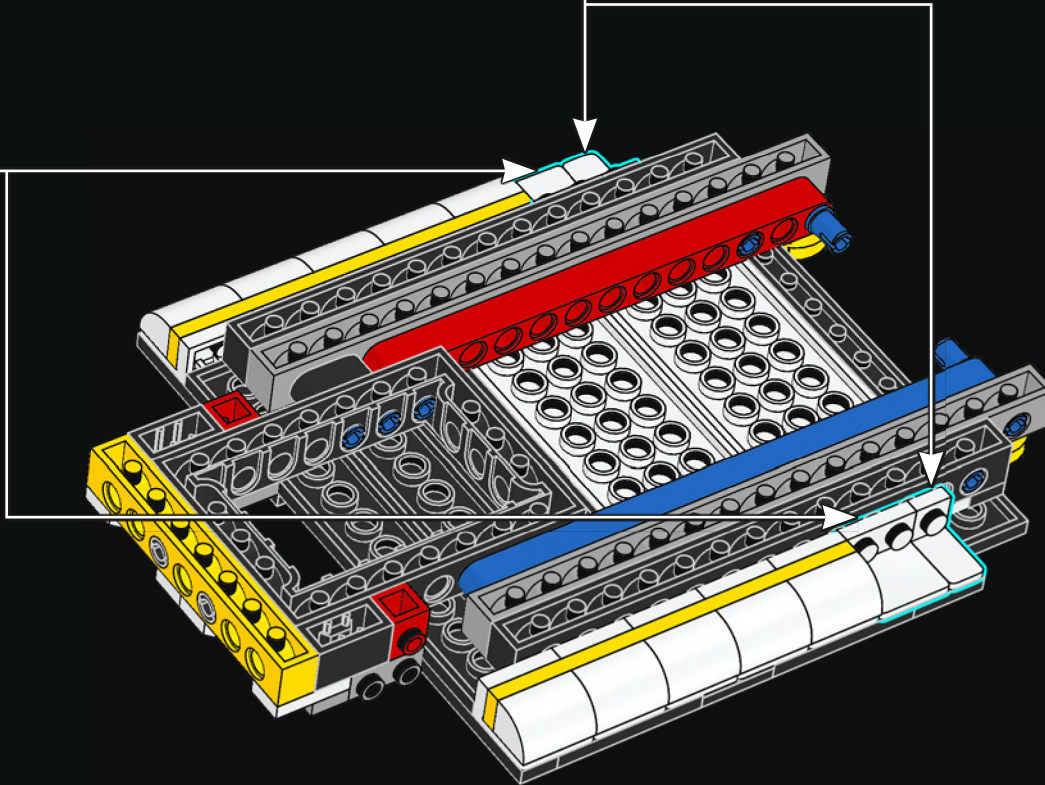
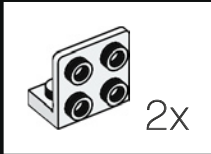

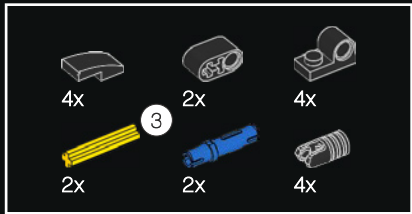
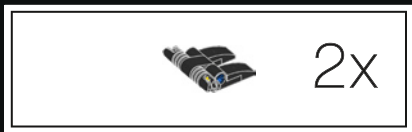

18

1

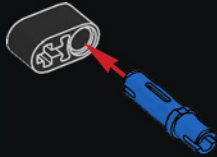

2

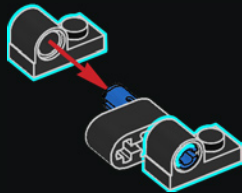

3

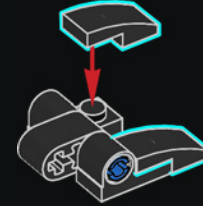

4

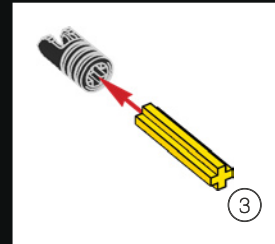

5

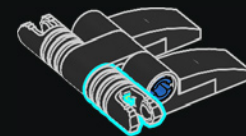

2x

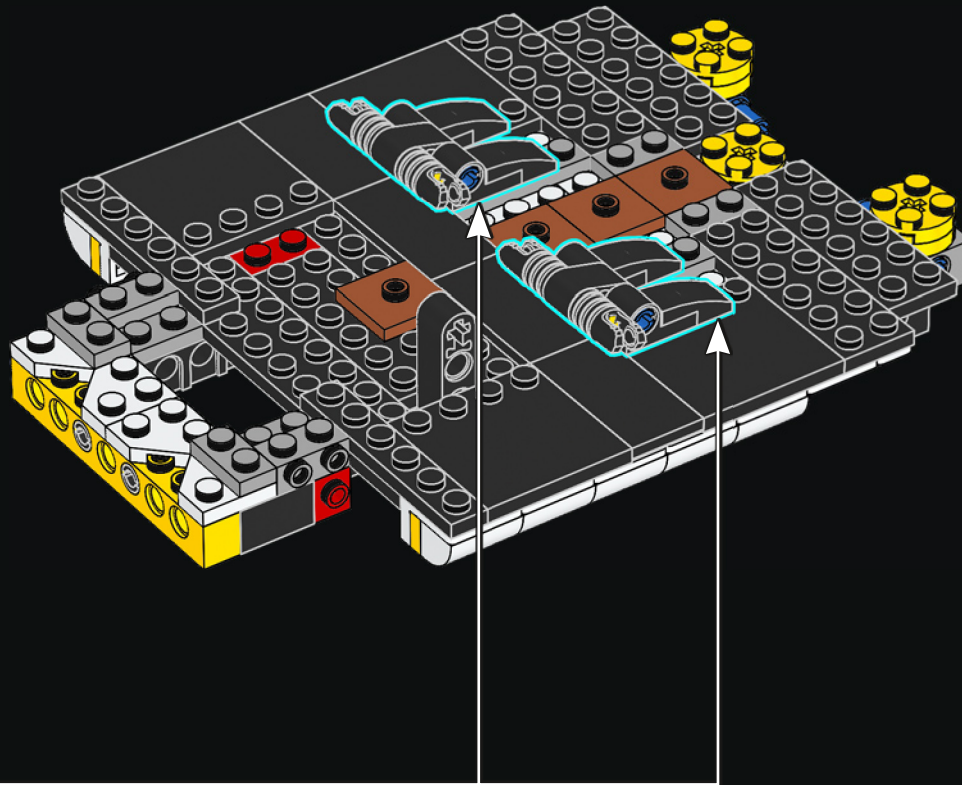

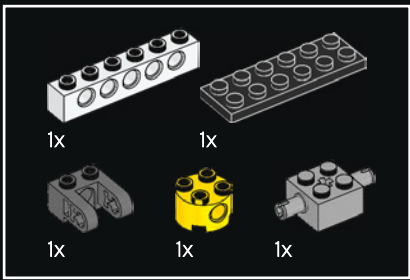

19

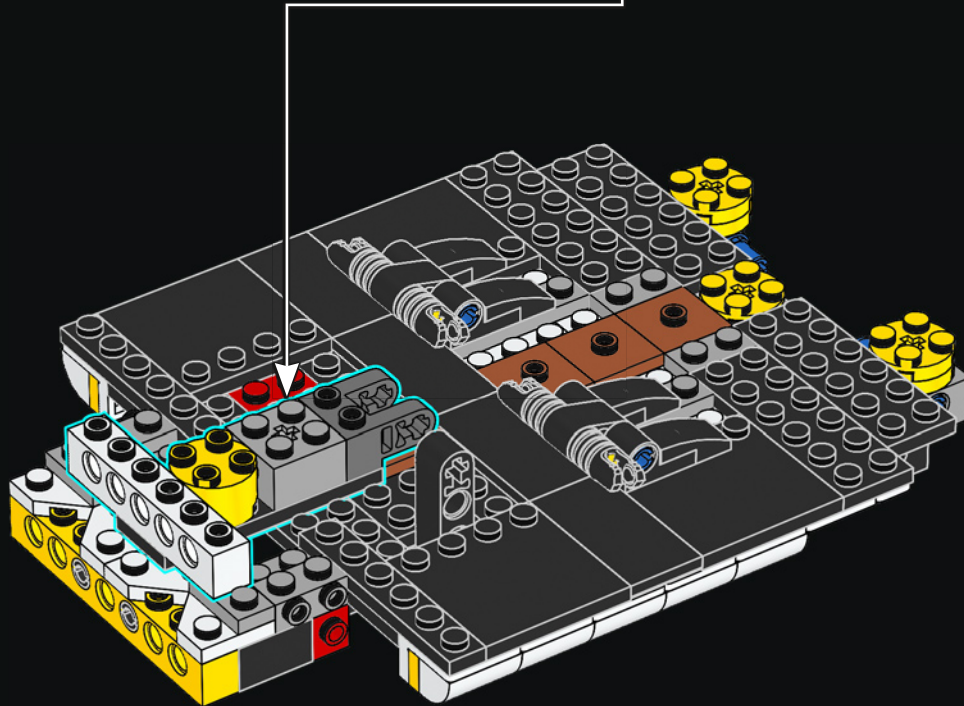
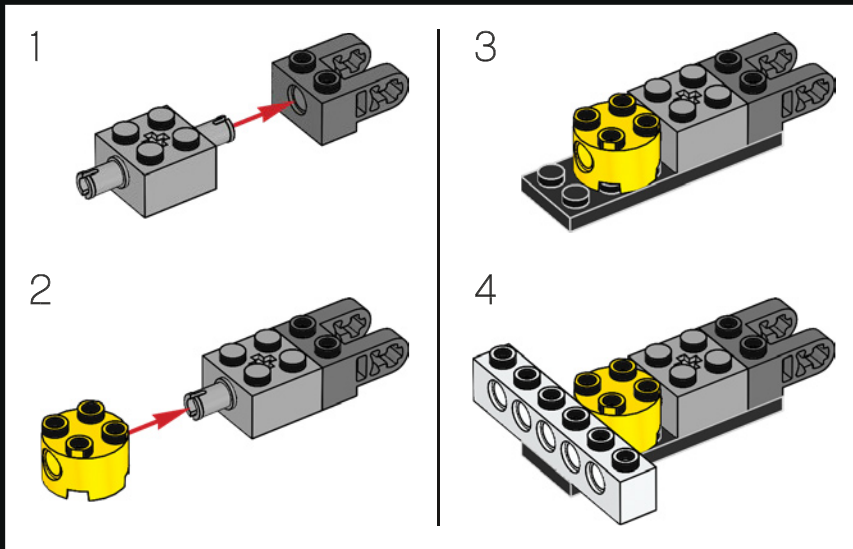

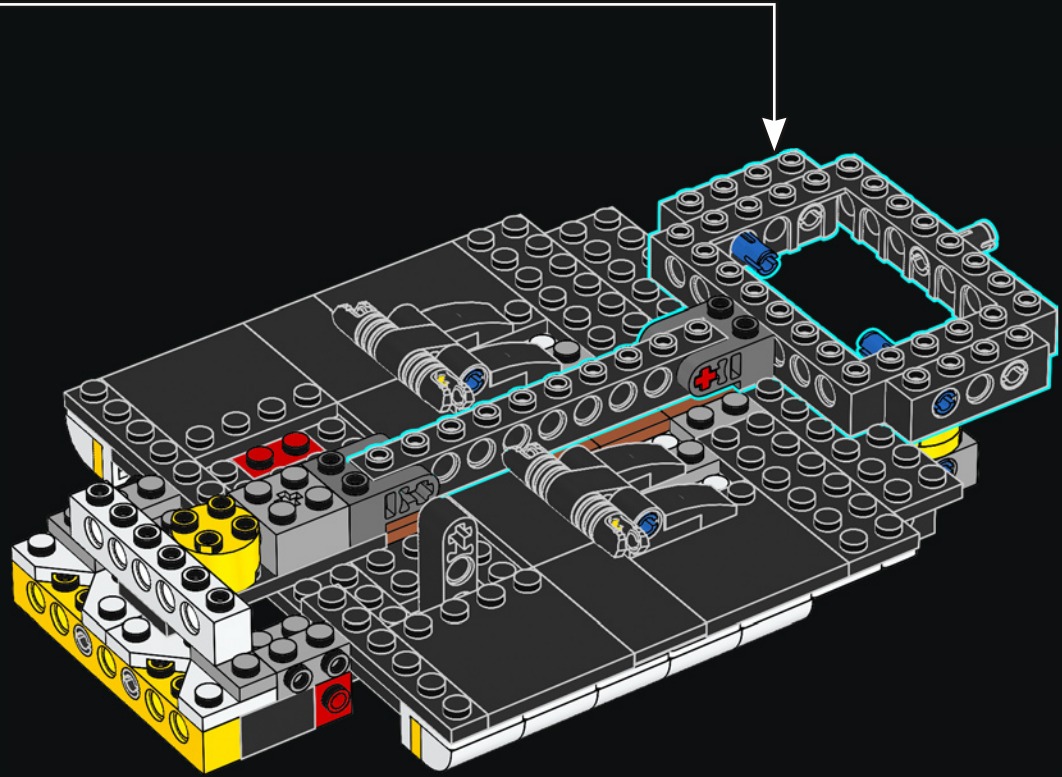



21

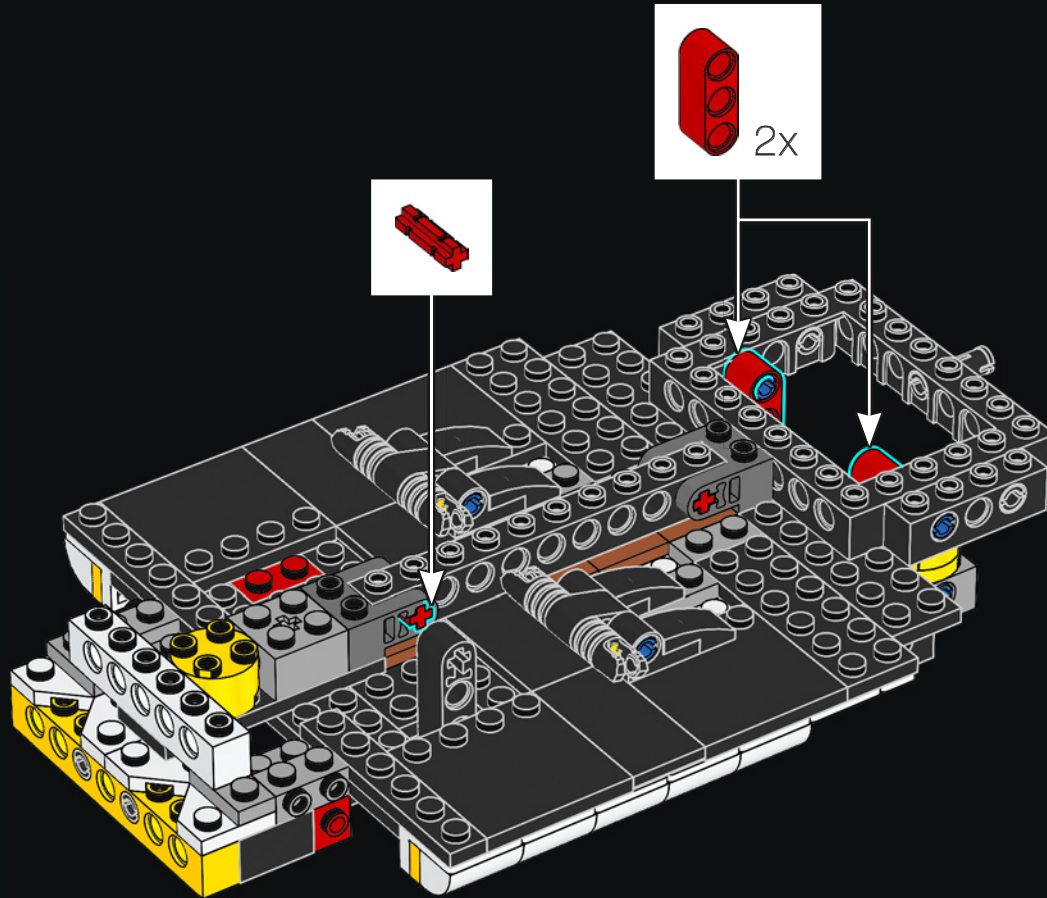

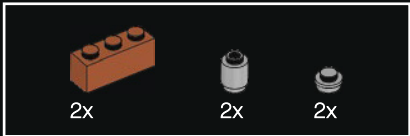
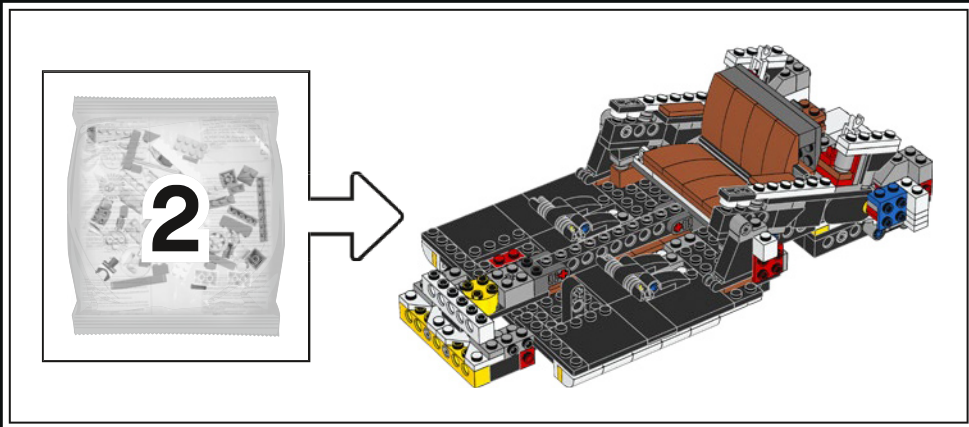

22

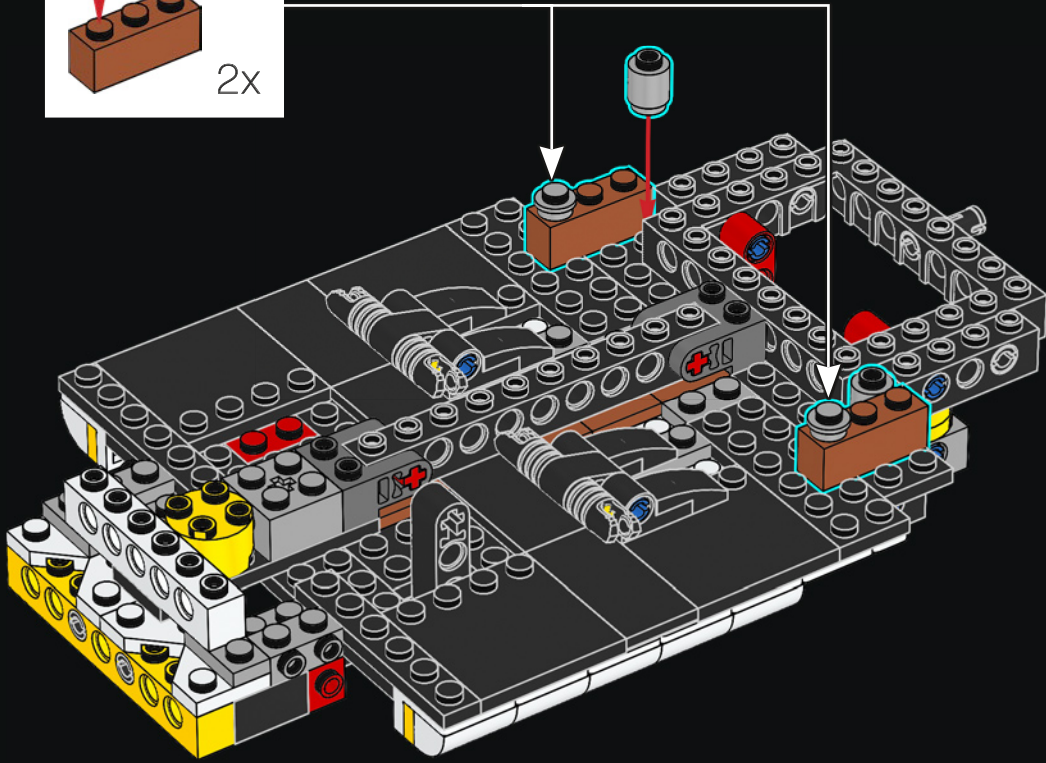
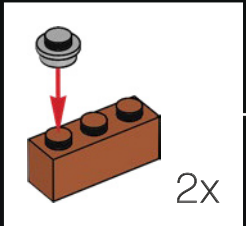



23

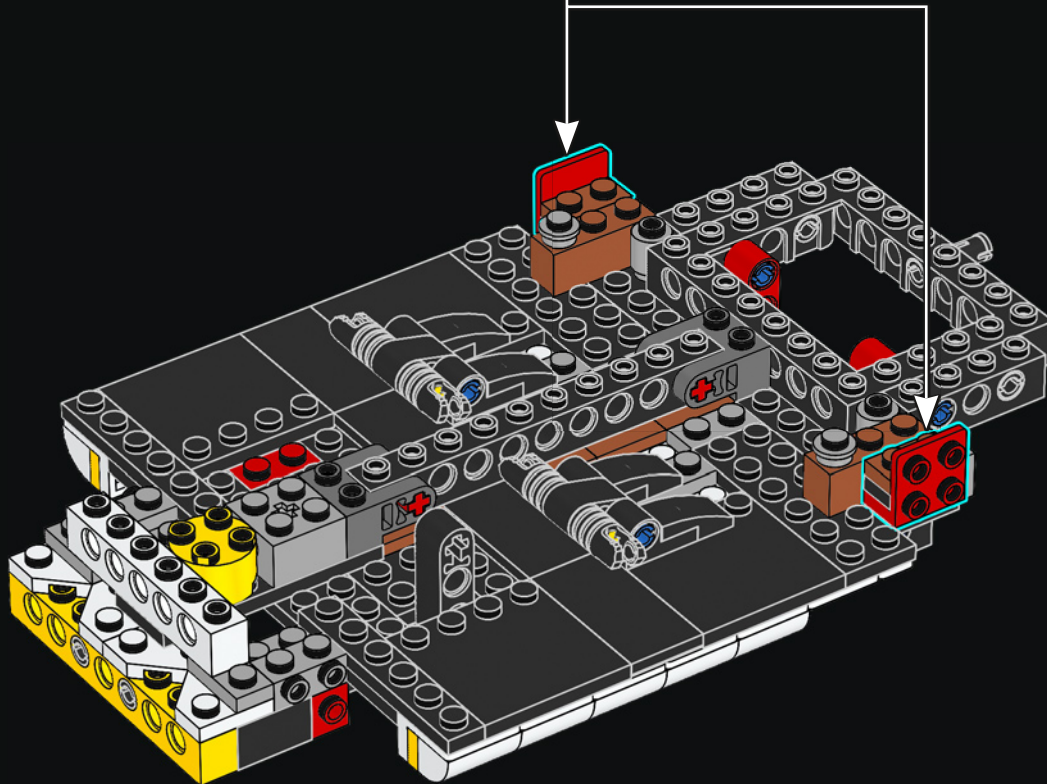
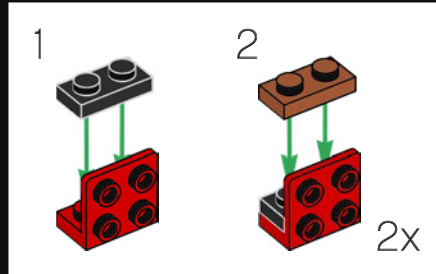

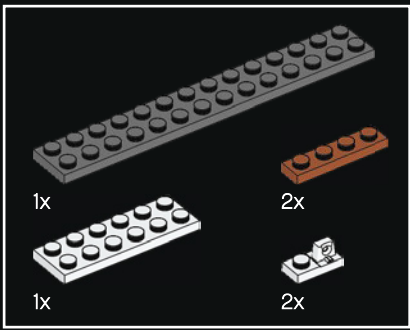

24

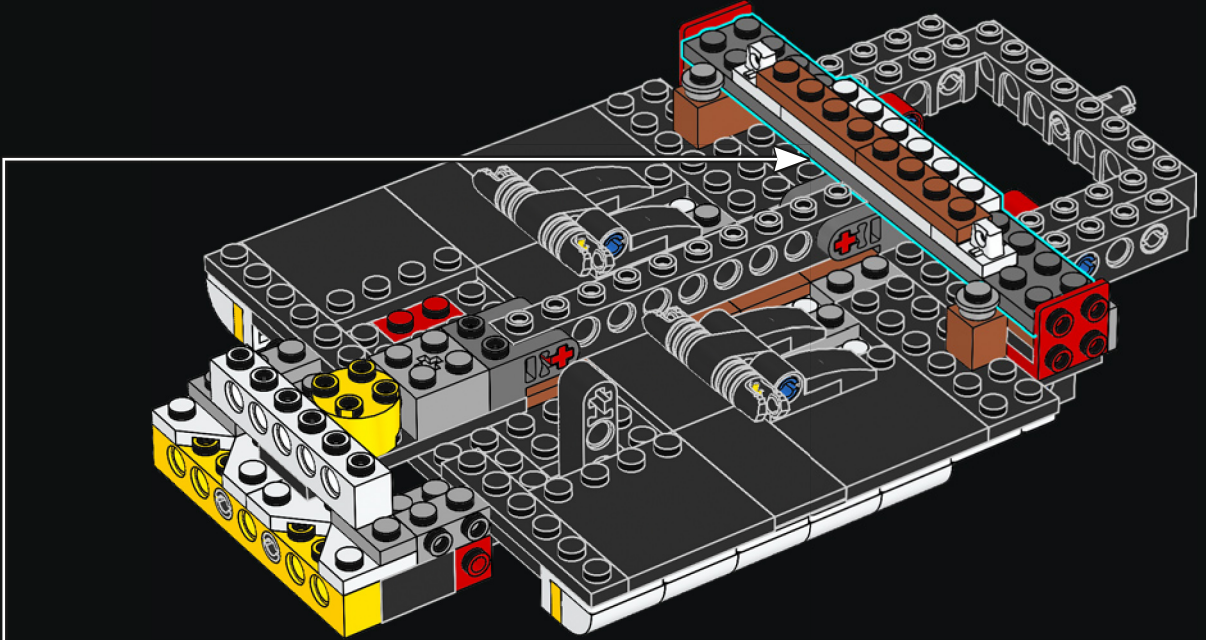
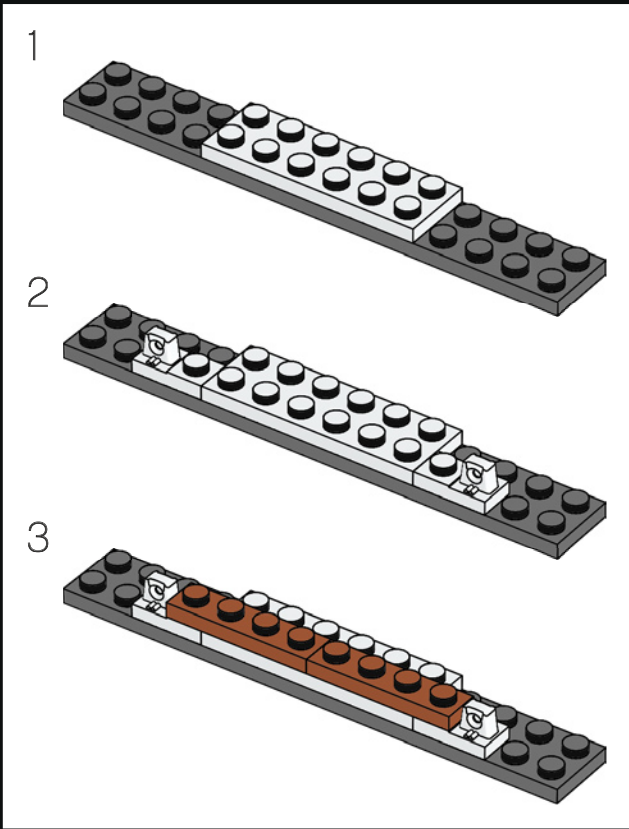

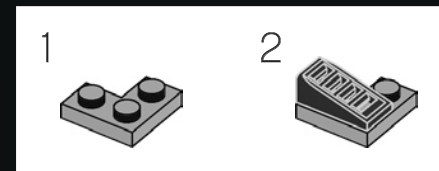

25

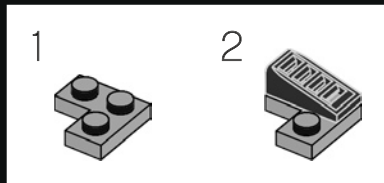
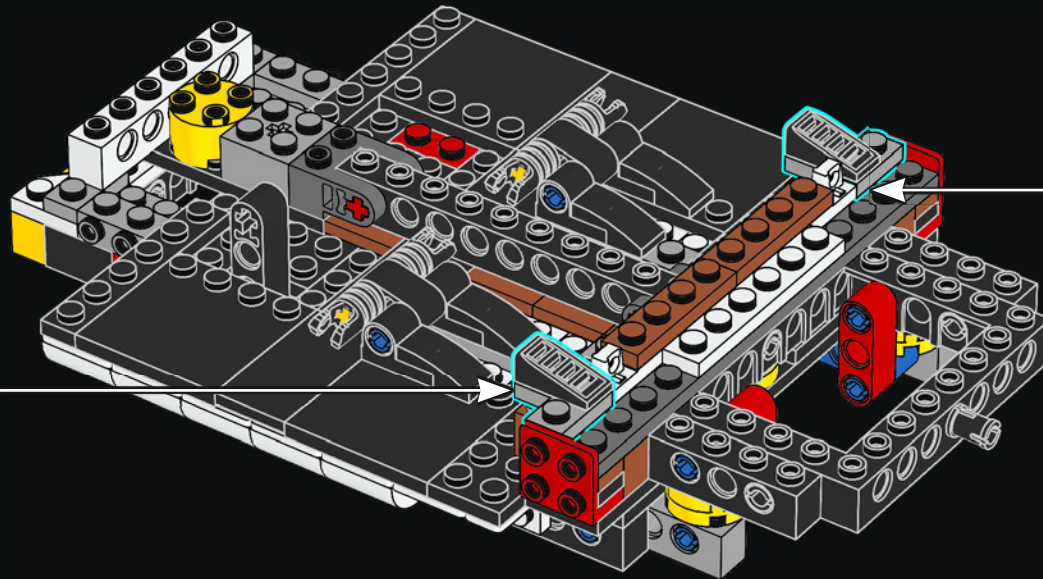

26

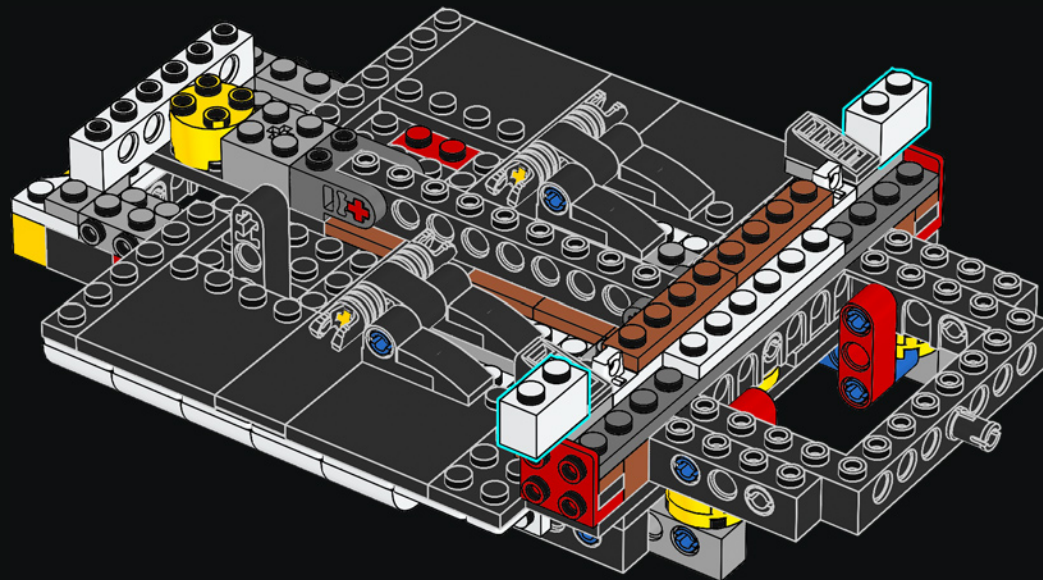

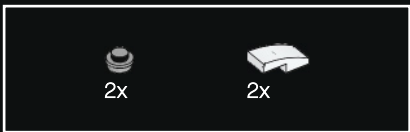

27

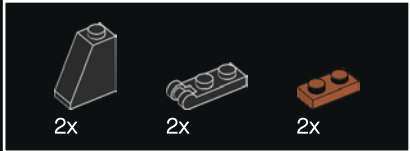
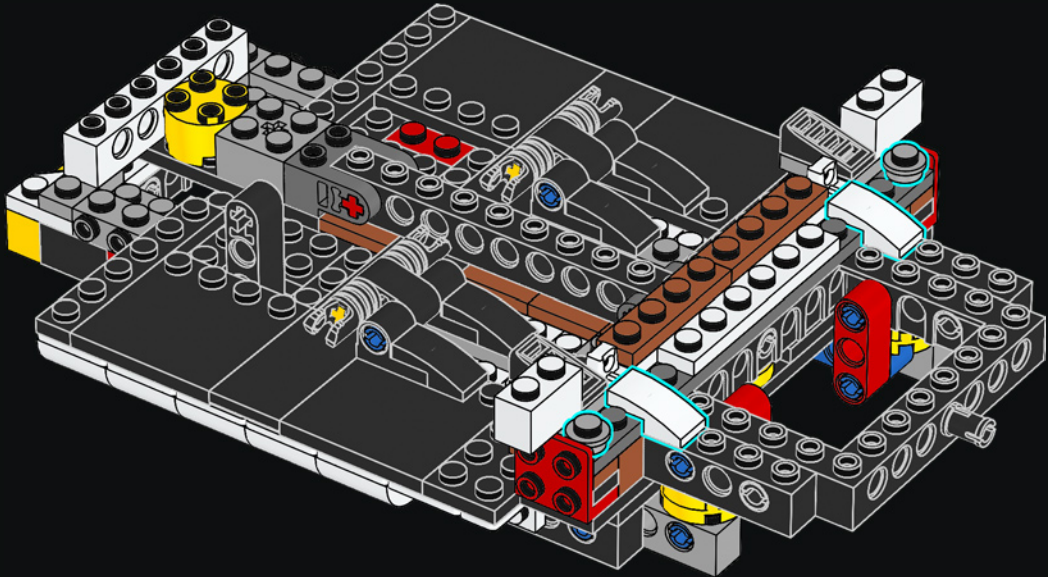

28

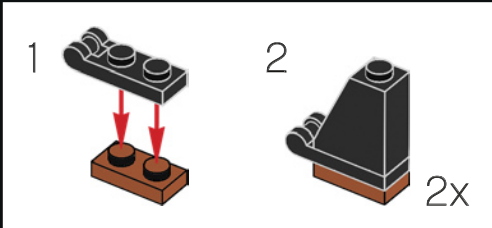
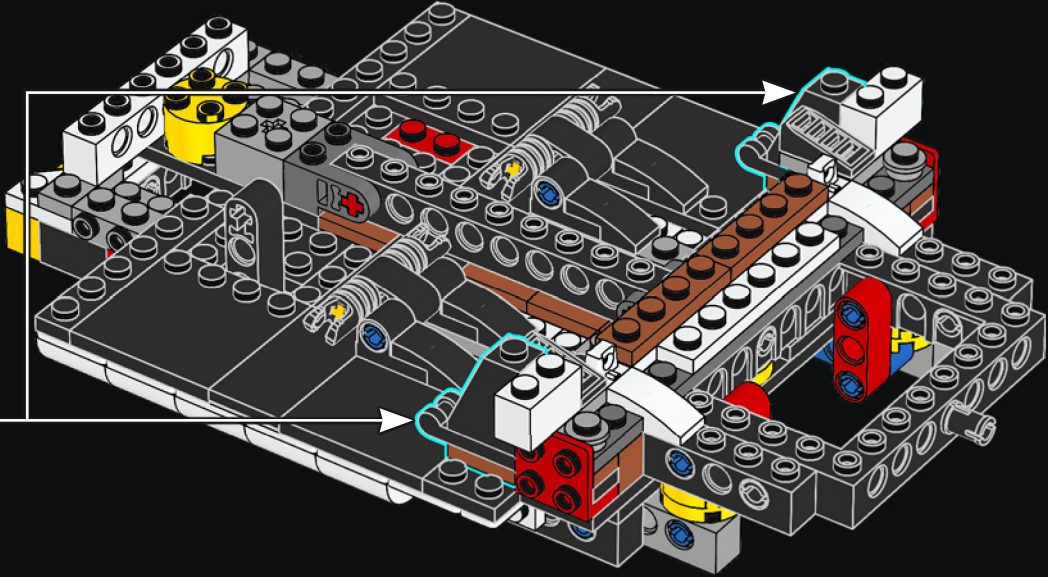

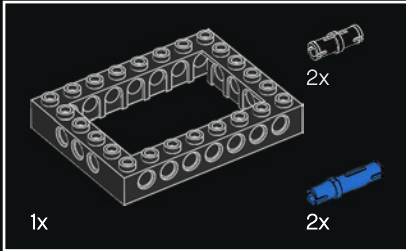
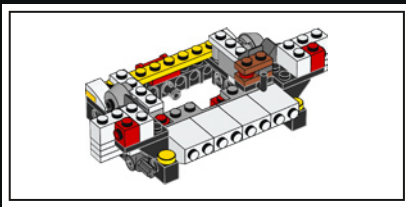

29

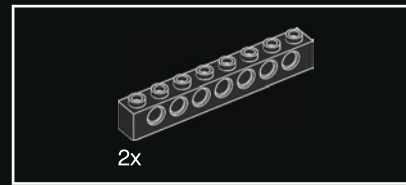
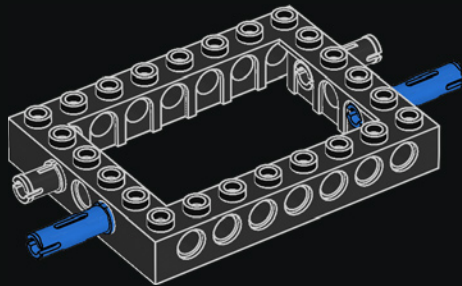

30

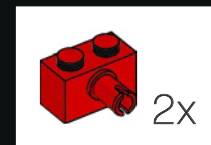
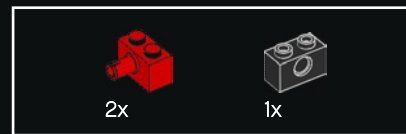
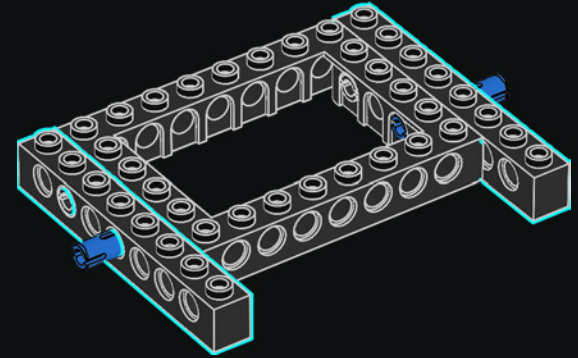

31

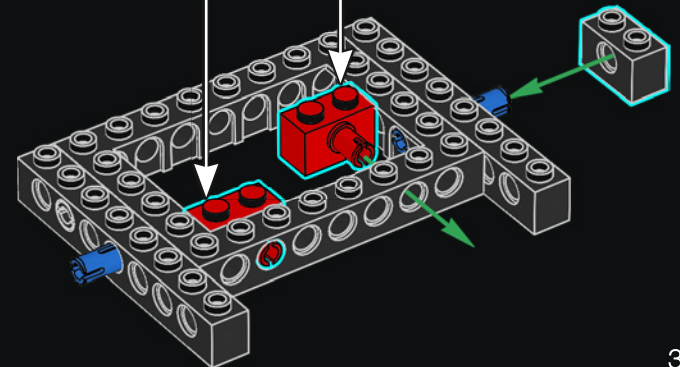



2x

32

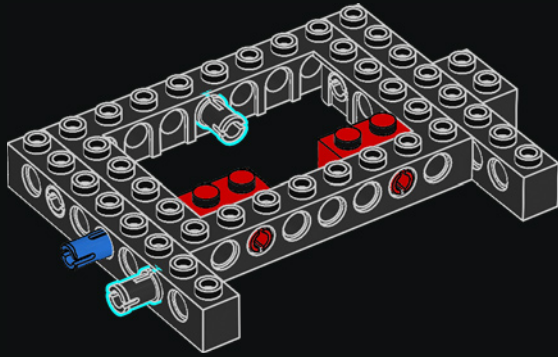

1x



1x

33

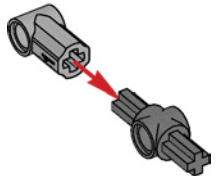
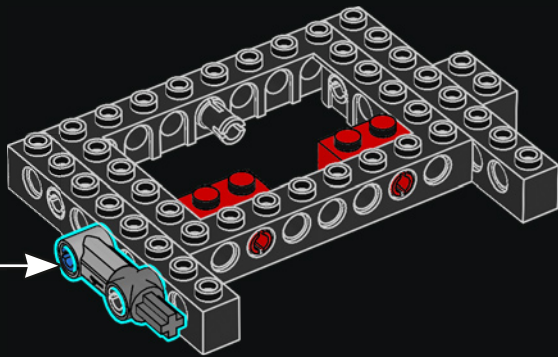

2x



2x



1x



2x

34

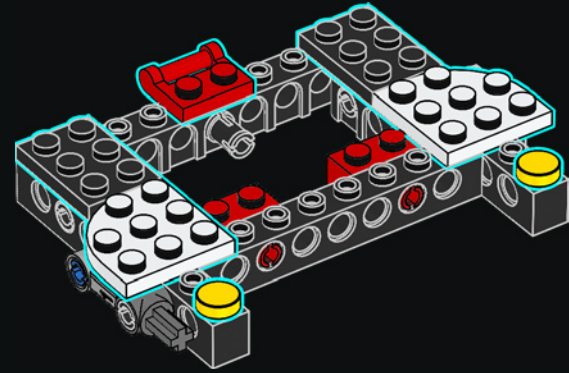

2x



2x

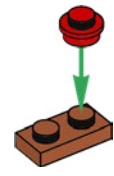

2x

35

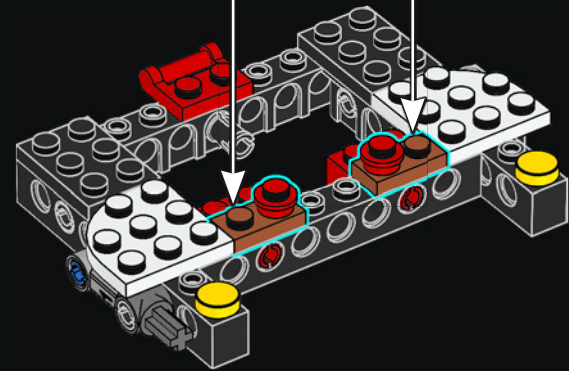

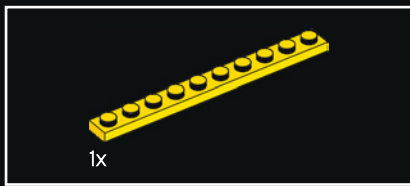

36

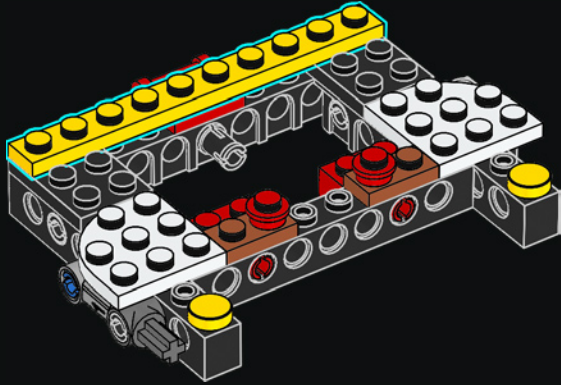

37

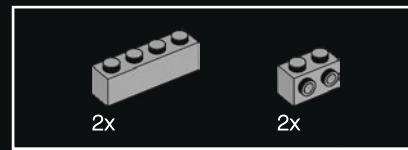
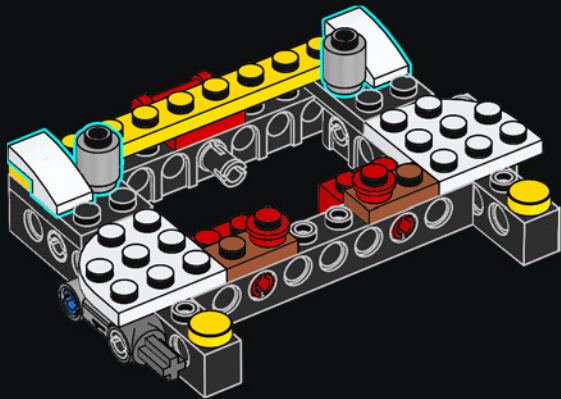

38

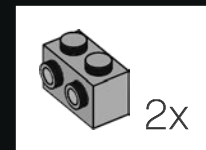
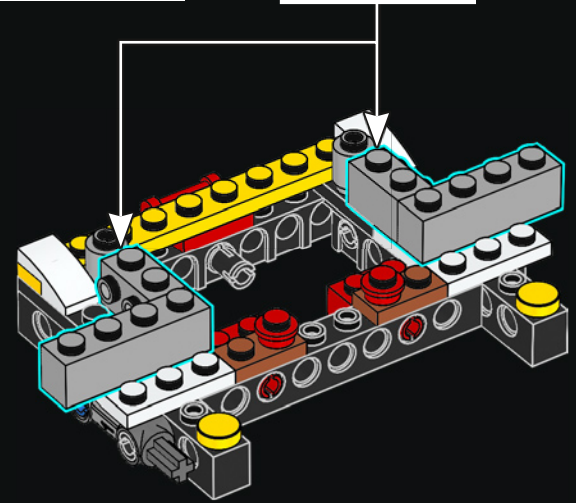

39

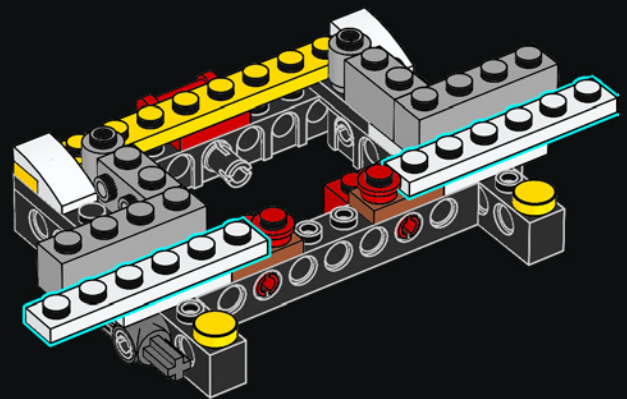
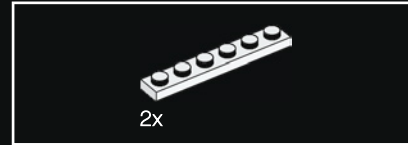



40

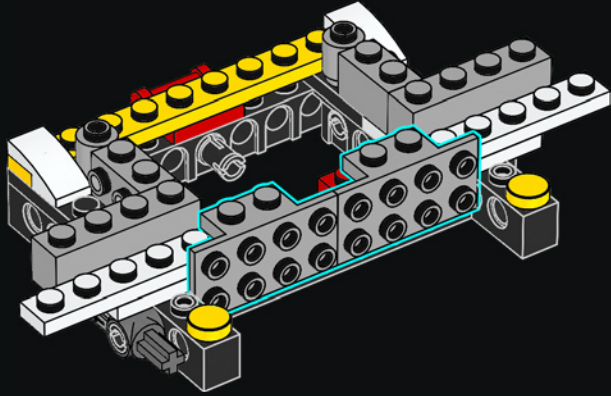

41

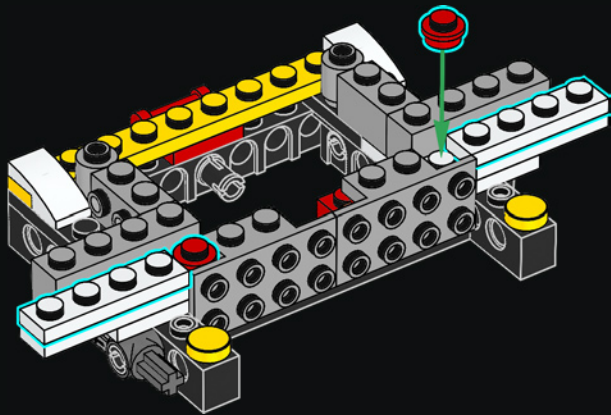

42

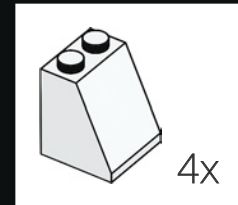
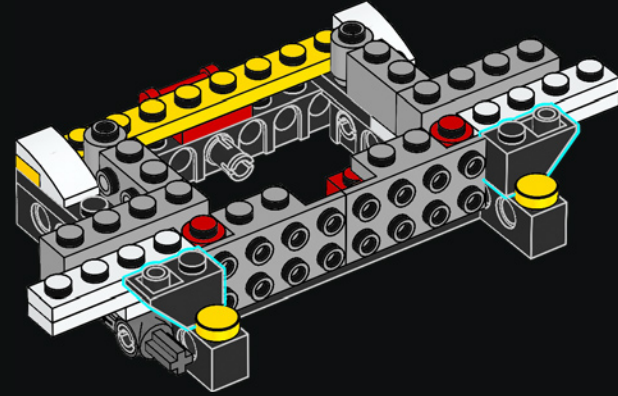

43

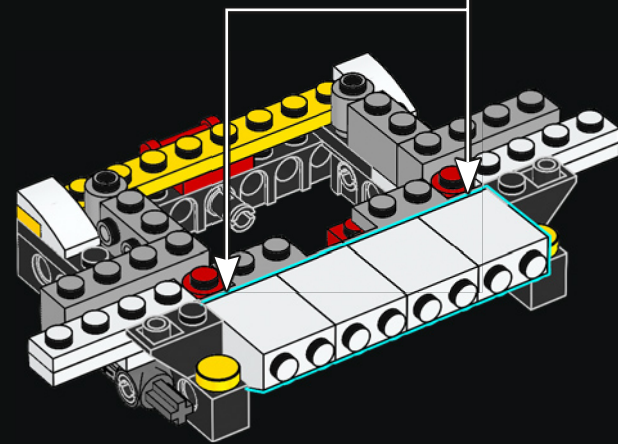



44

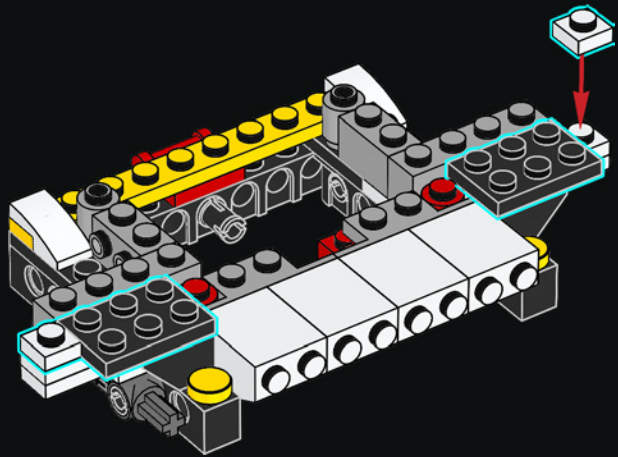

45

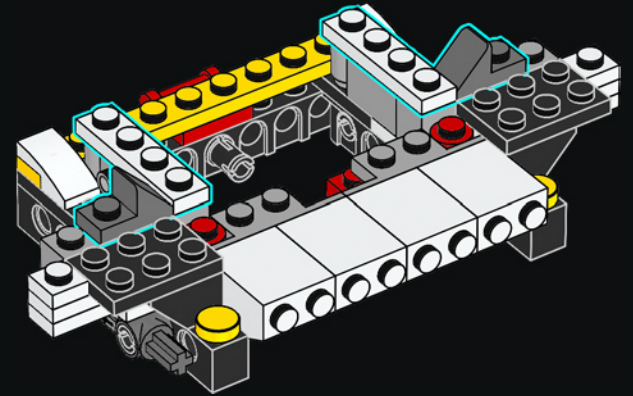



46

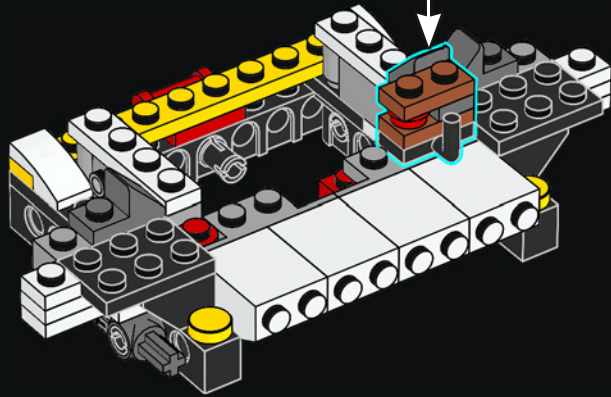
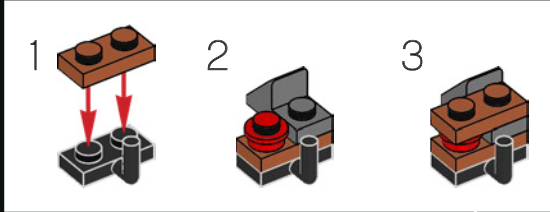

47

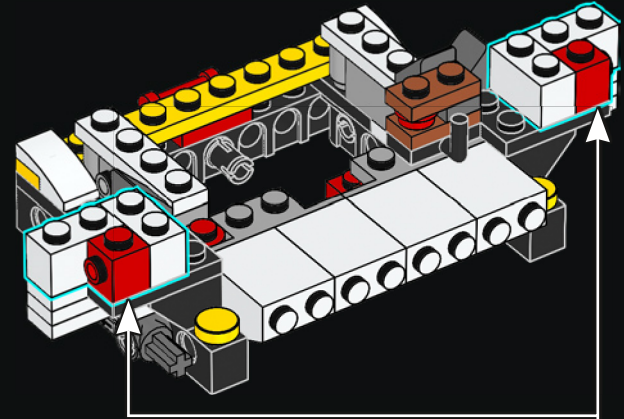

48

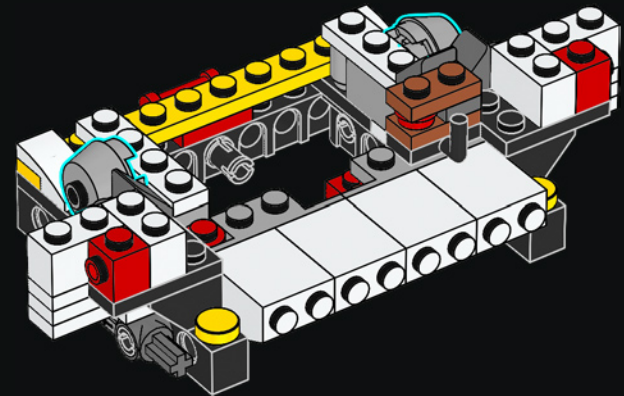

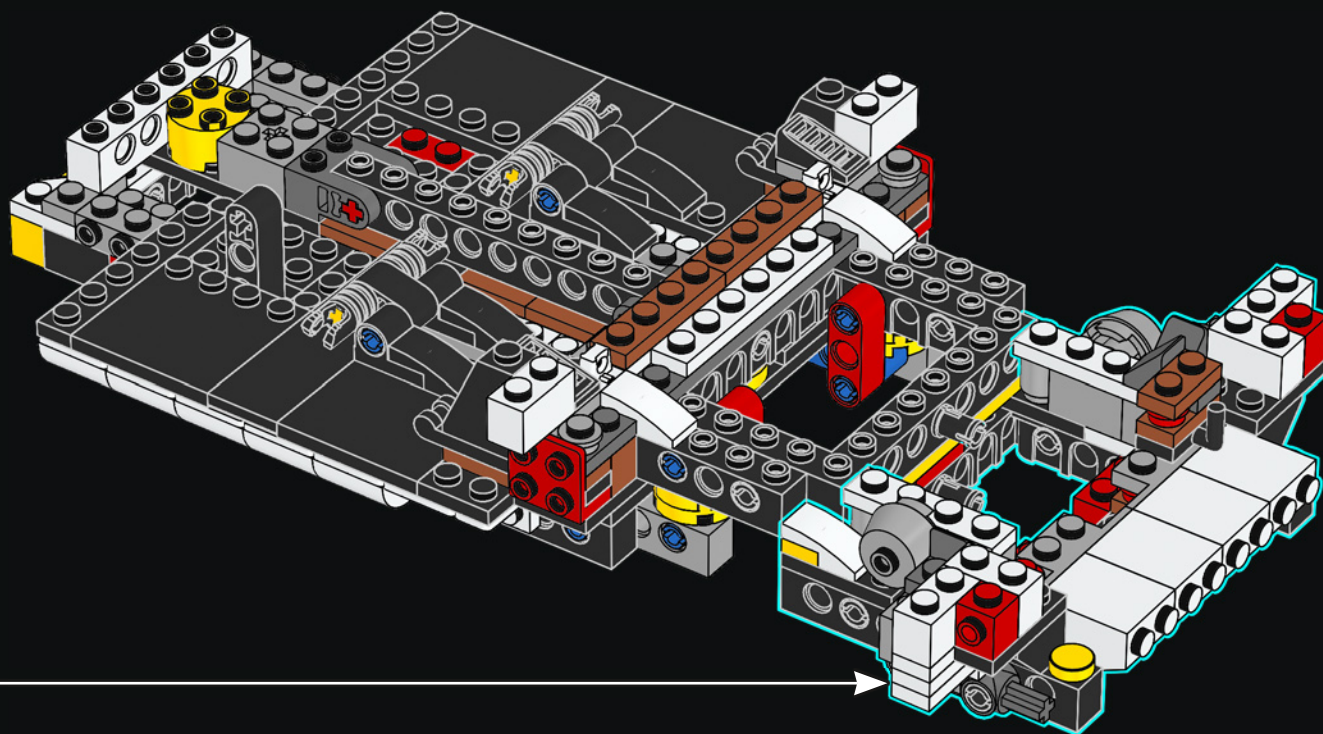

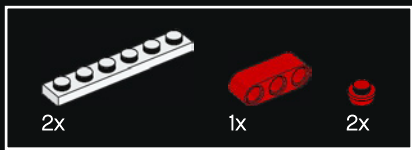

50

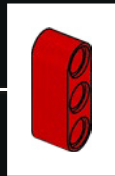
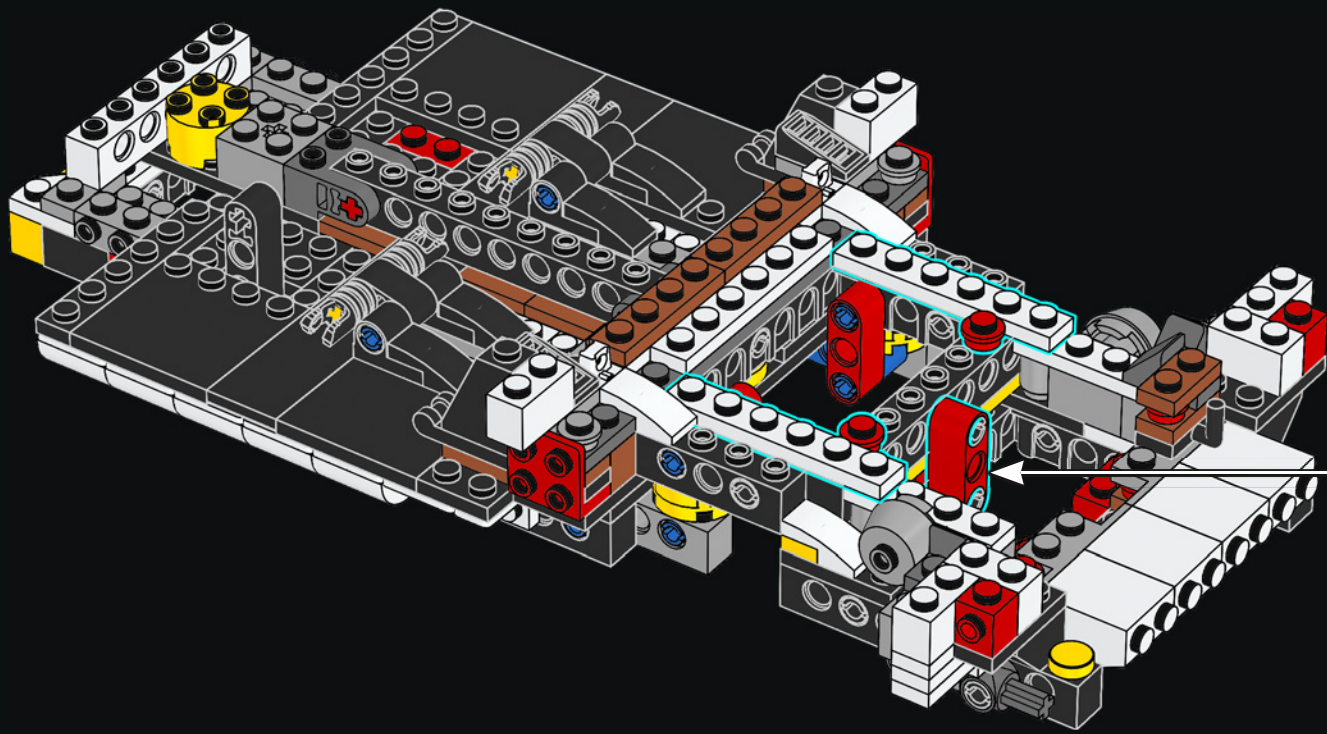



51

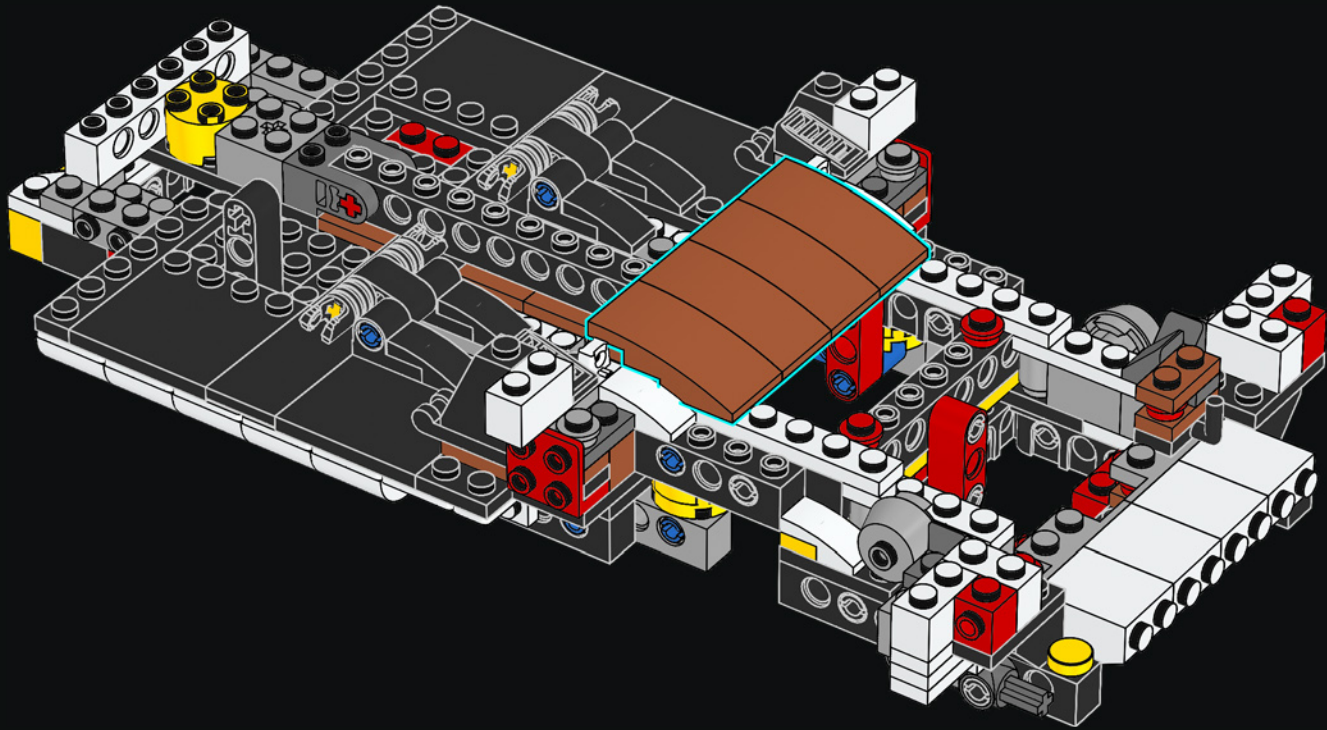

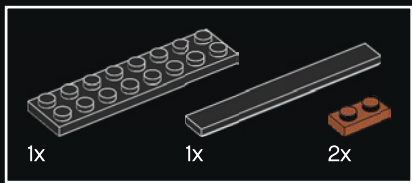

52

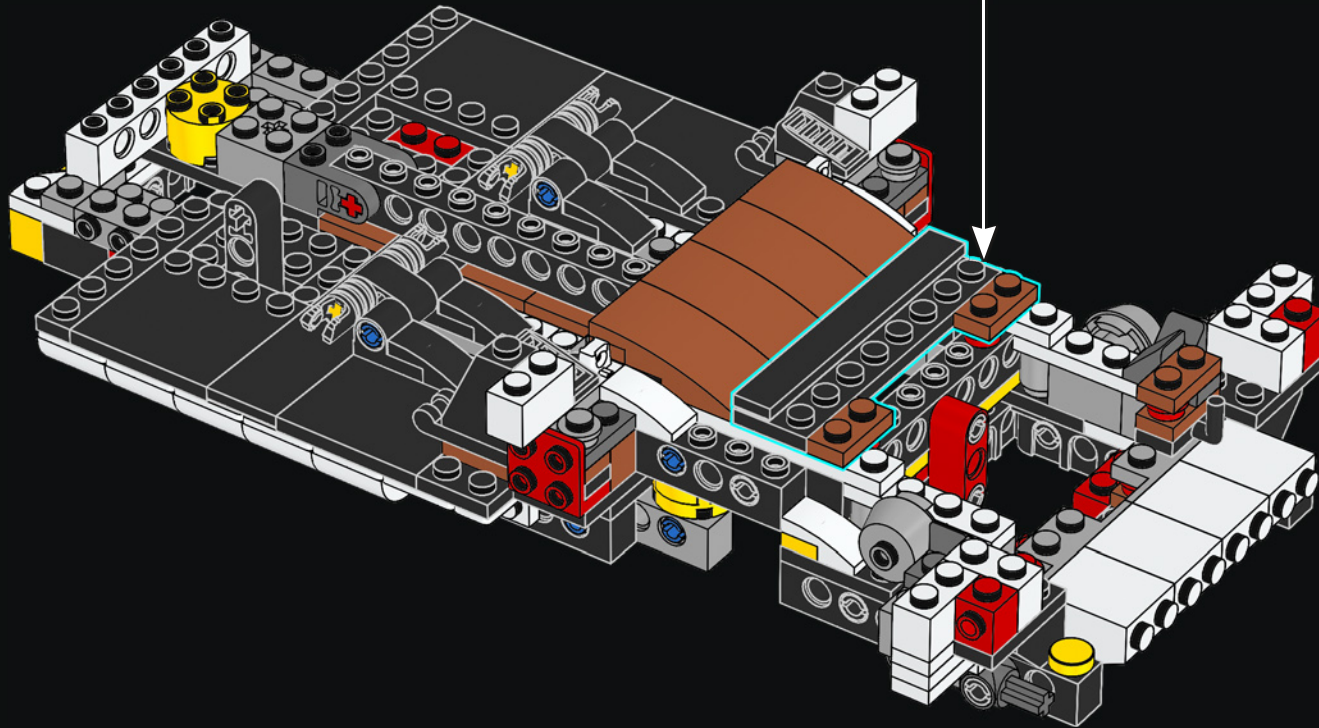
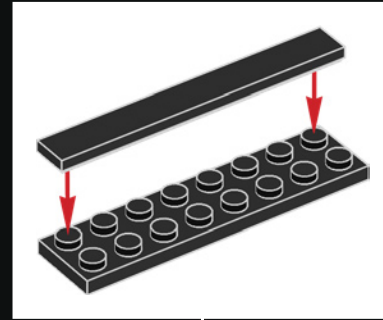

As the rear seats were very small, the 911 was termed a "2+2" rather a "four-seater".

Wegen der sehr kleinen Rücksitze wurde der 911 als „2+2-Sitzer“ bezeichnet, und nicht etwa als „Viersitzer“.

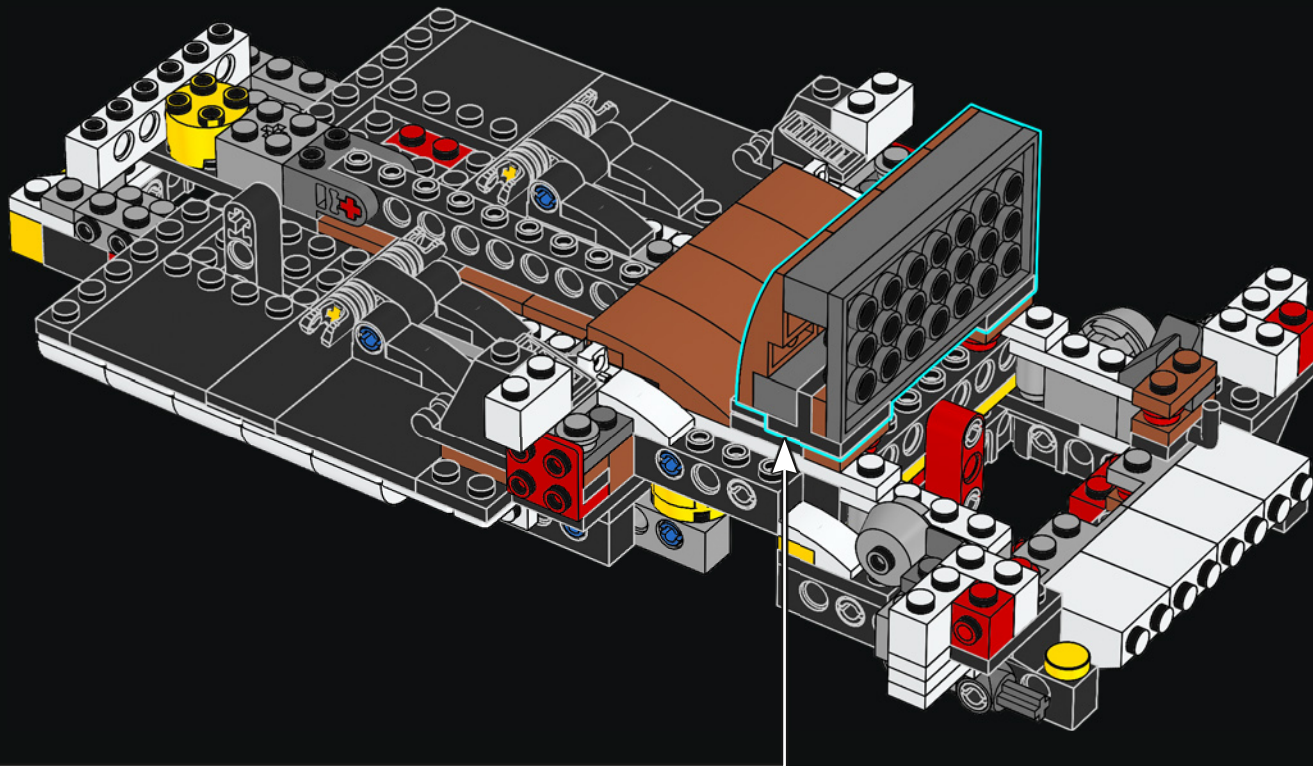

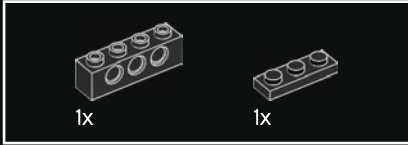
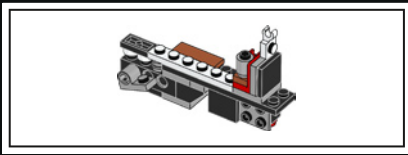

54

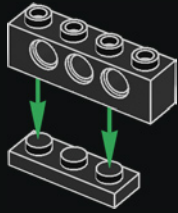

55

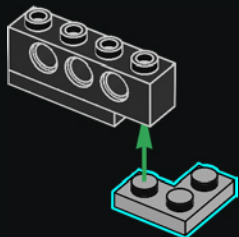

56

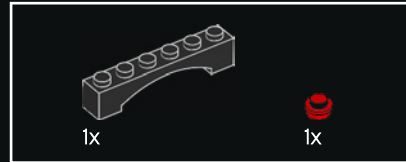
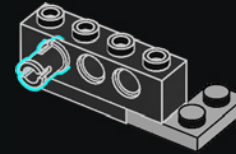

57

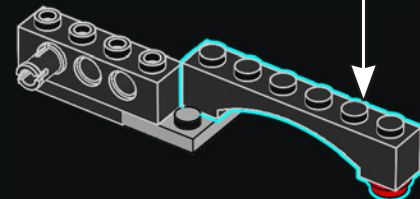
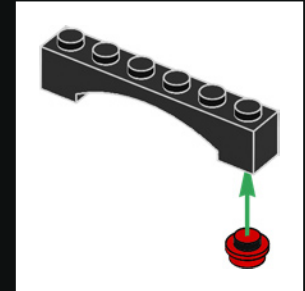



58

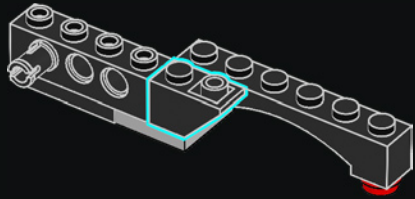

59

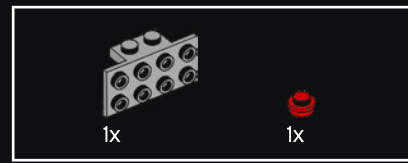
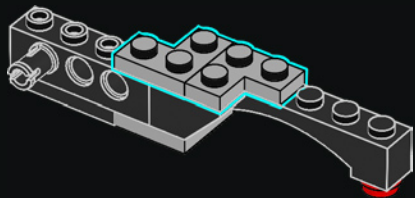

60

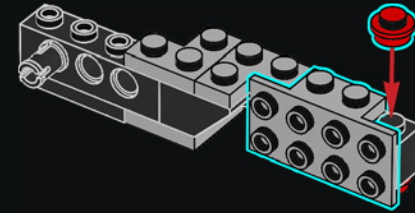

61

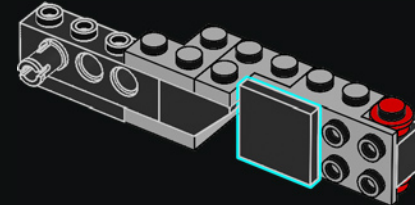

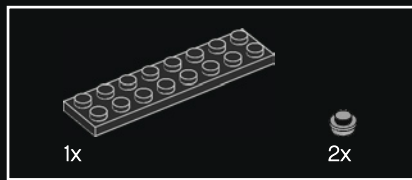

62

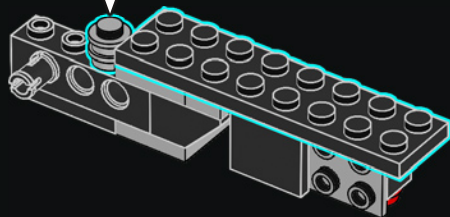
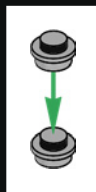

63

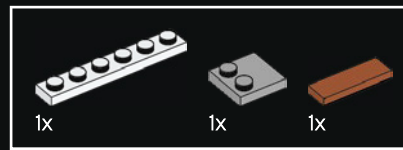
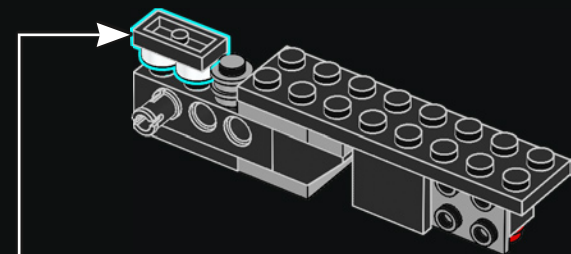
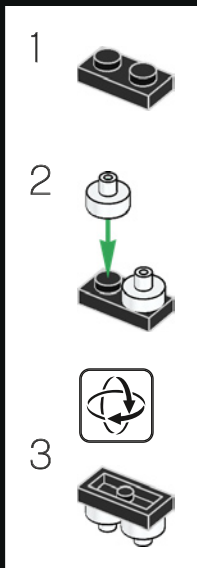

64

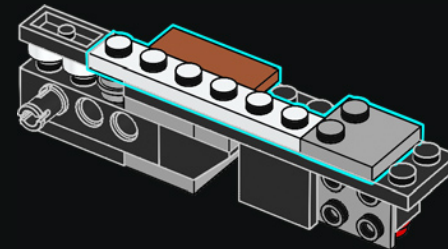

65

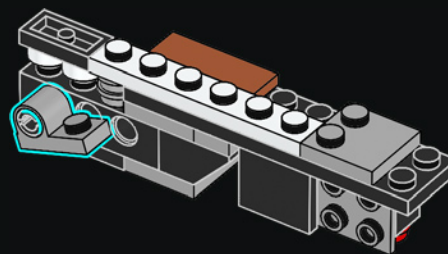

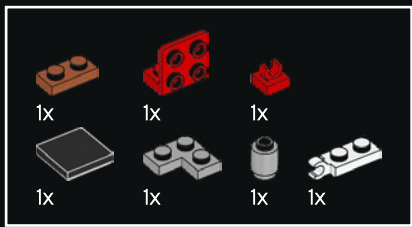

66

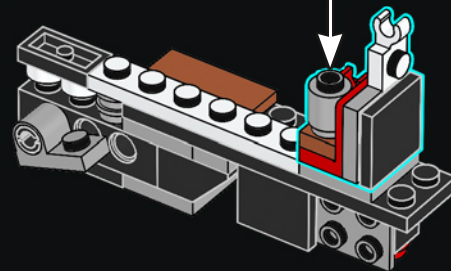
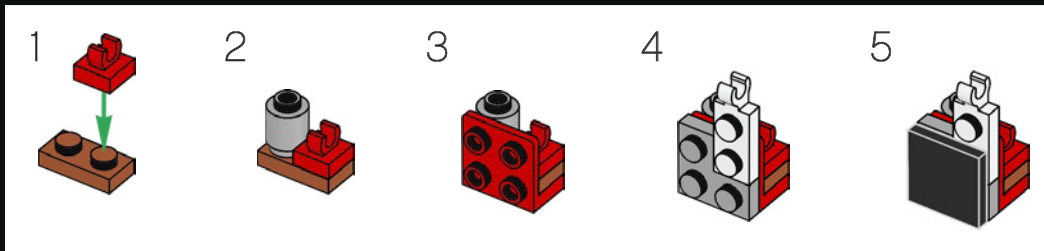

67

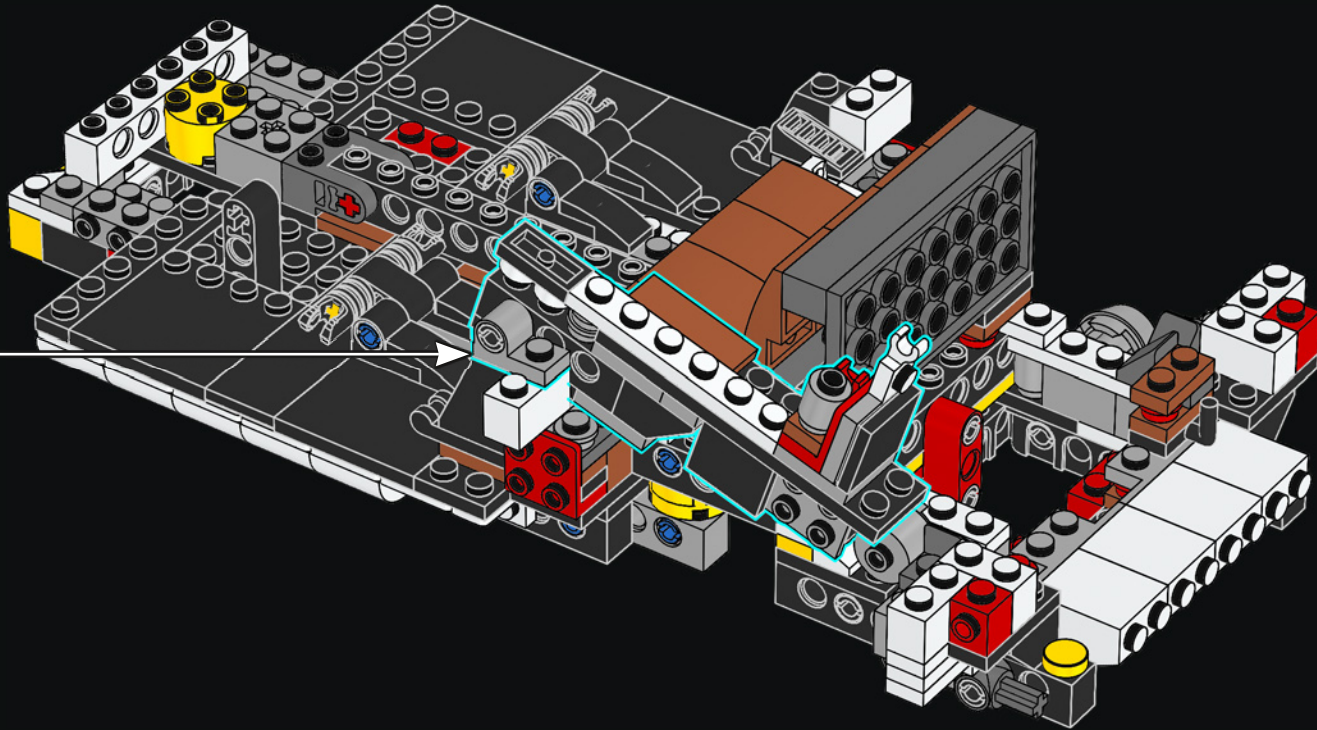



68

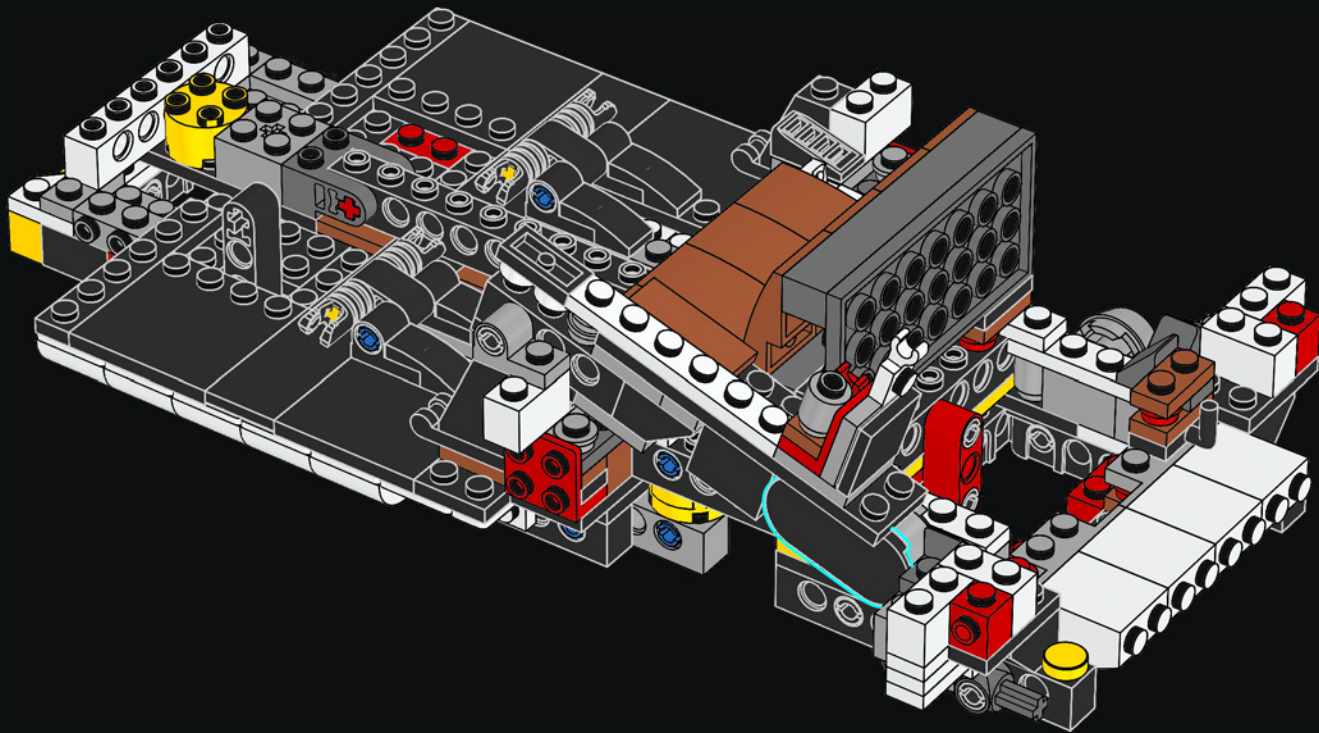

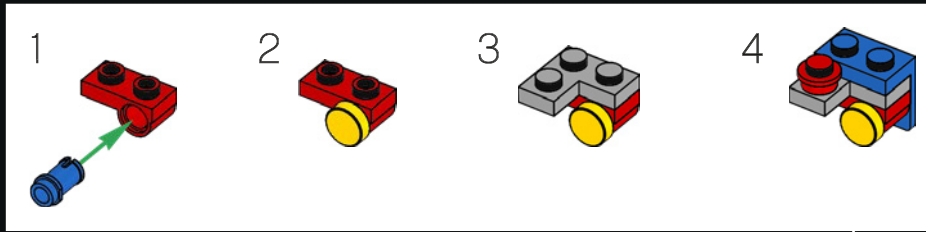
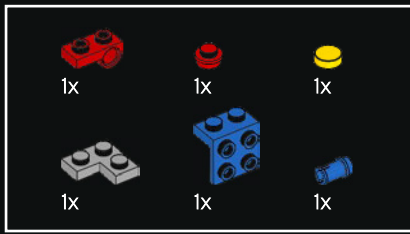

69

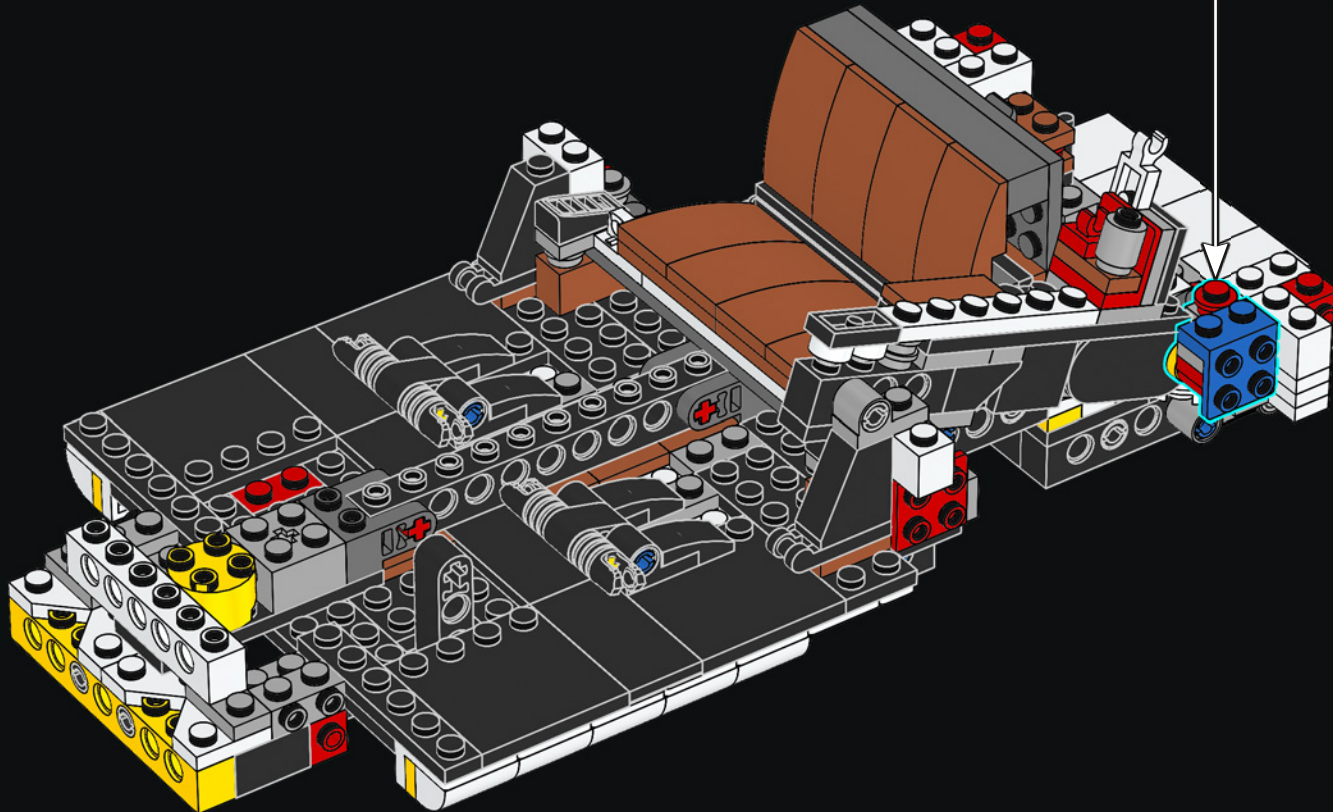

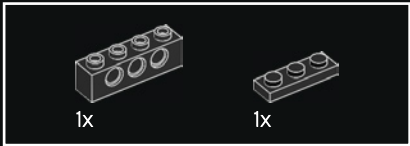
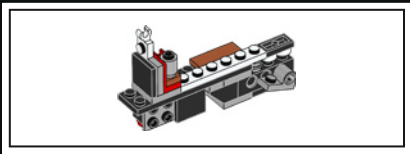

70

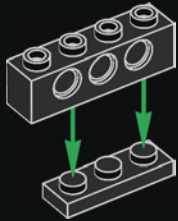

71

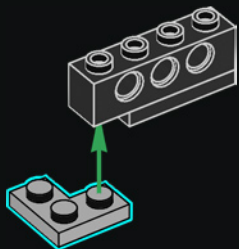

72

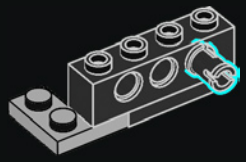

73

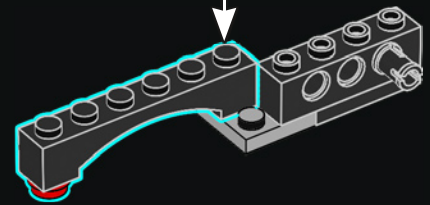
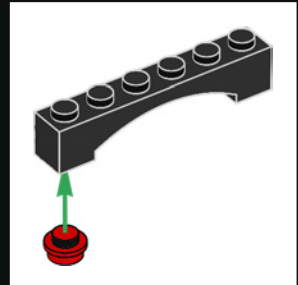



74

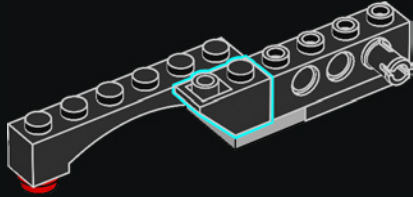

75

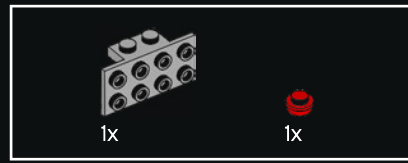
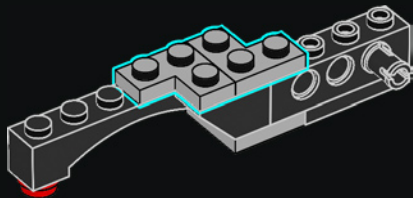

76

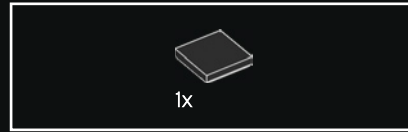
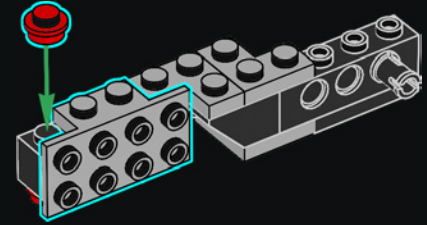

77

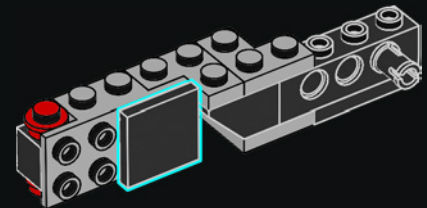

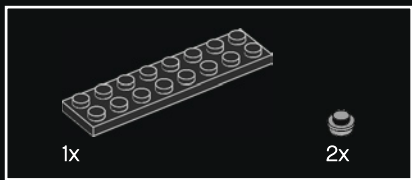

78

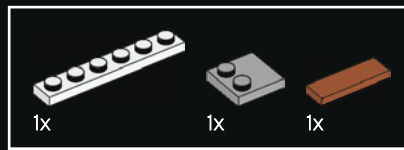
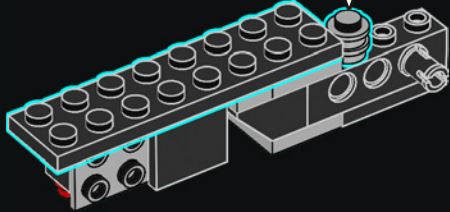
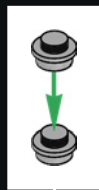

80

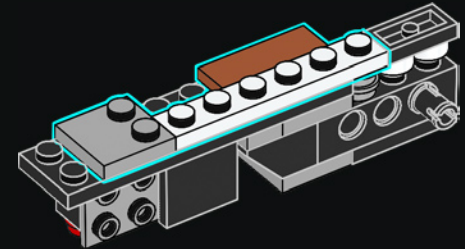

79

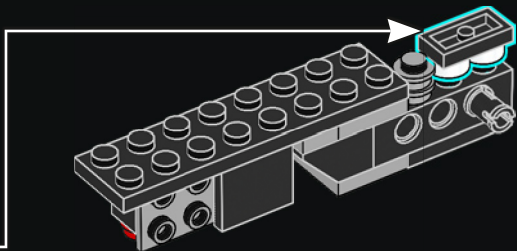
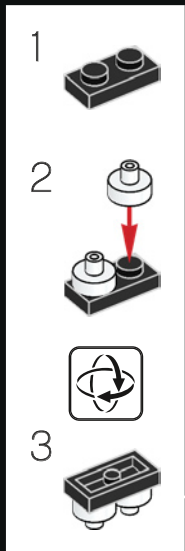

81

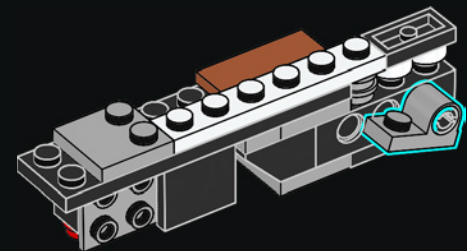

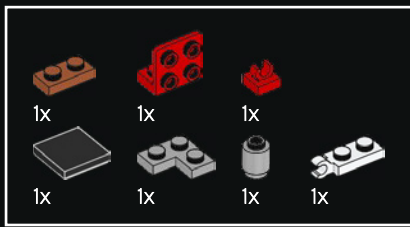

82

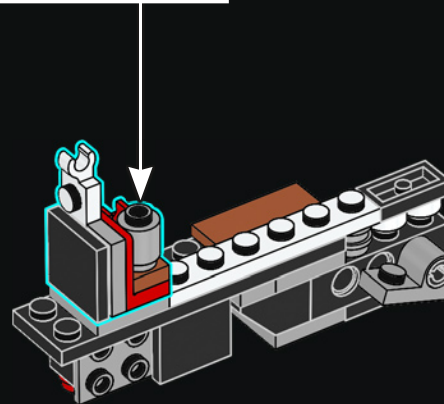
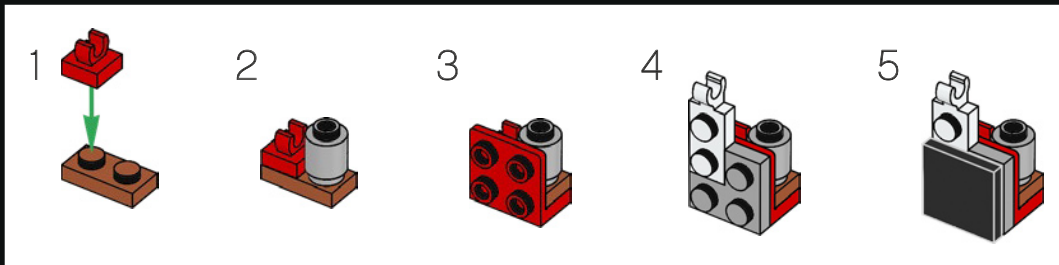

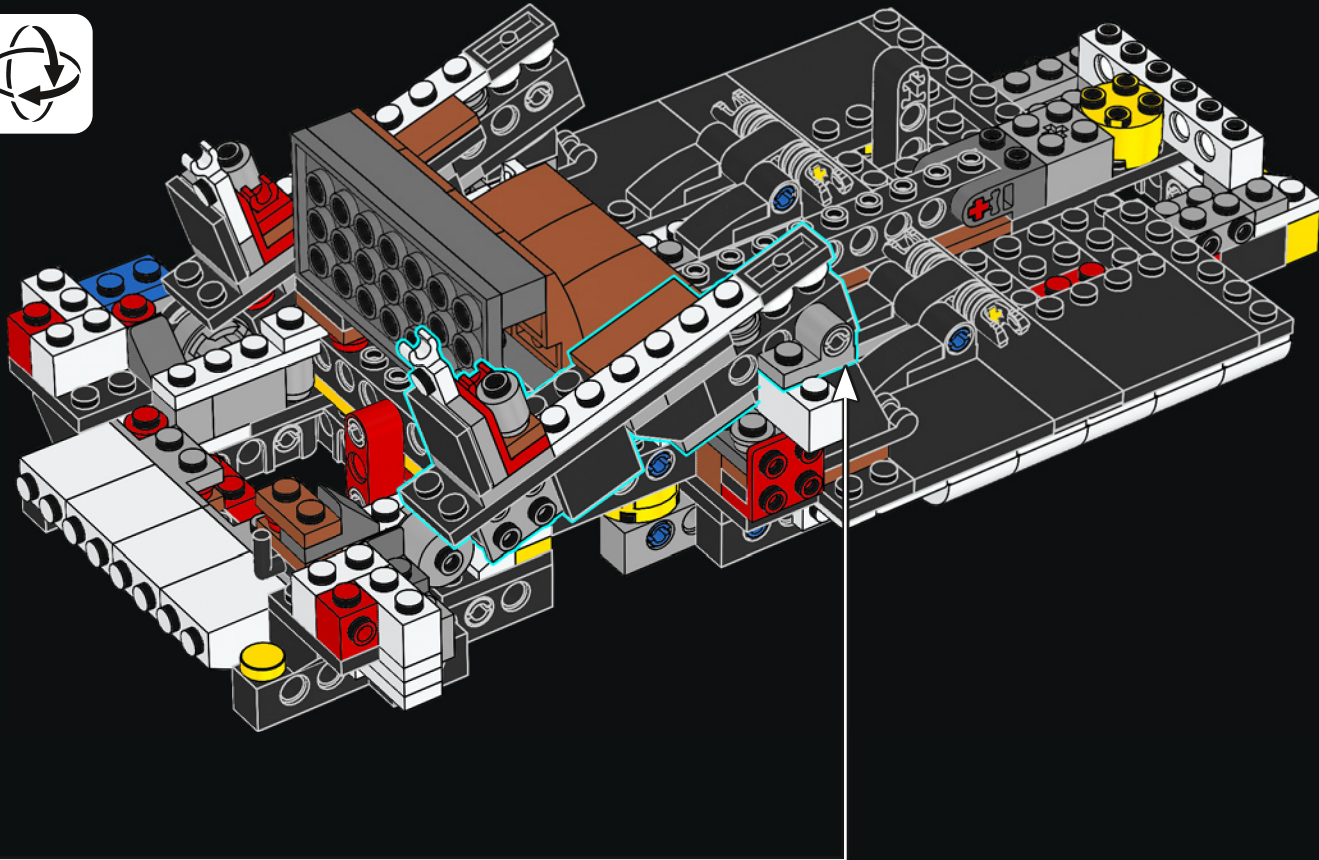



84

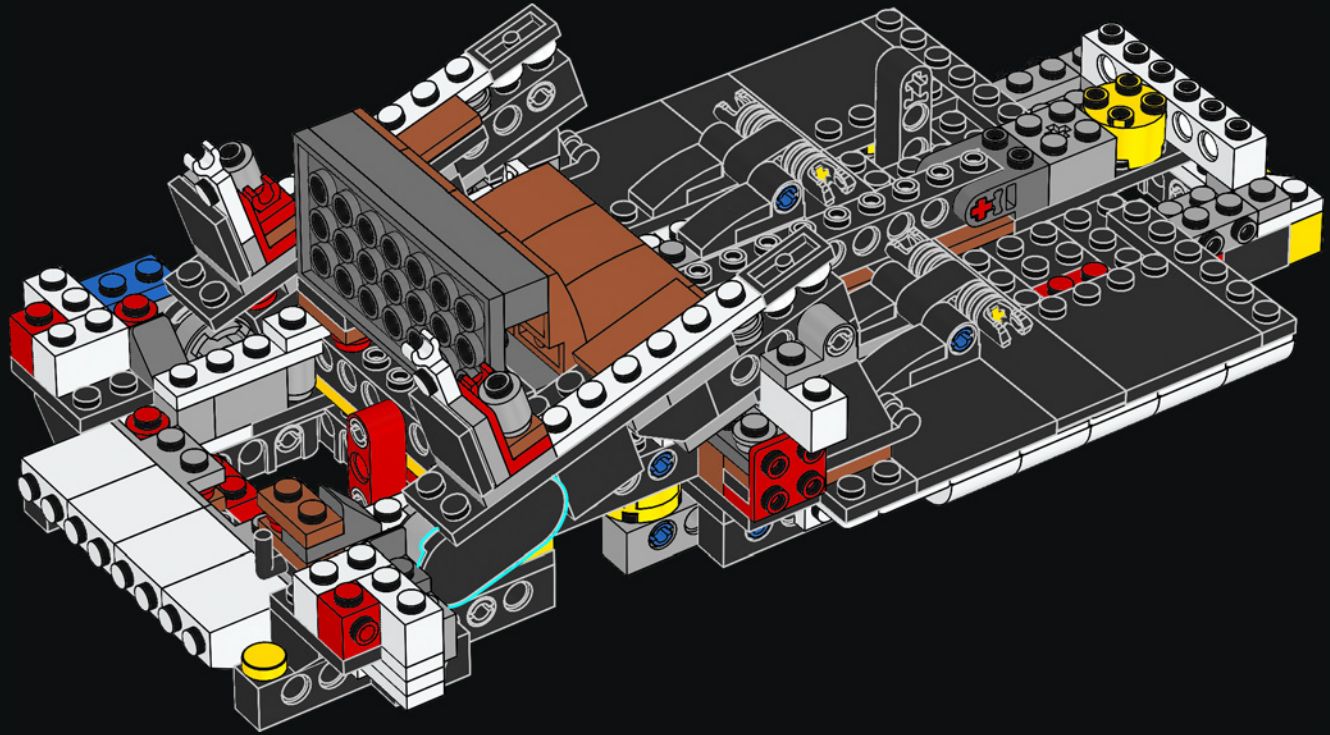

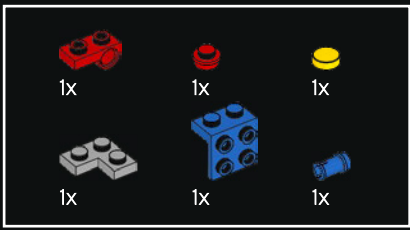

85

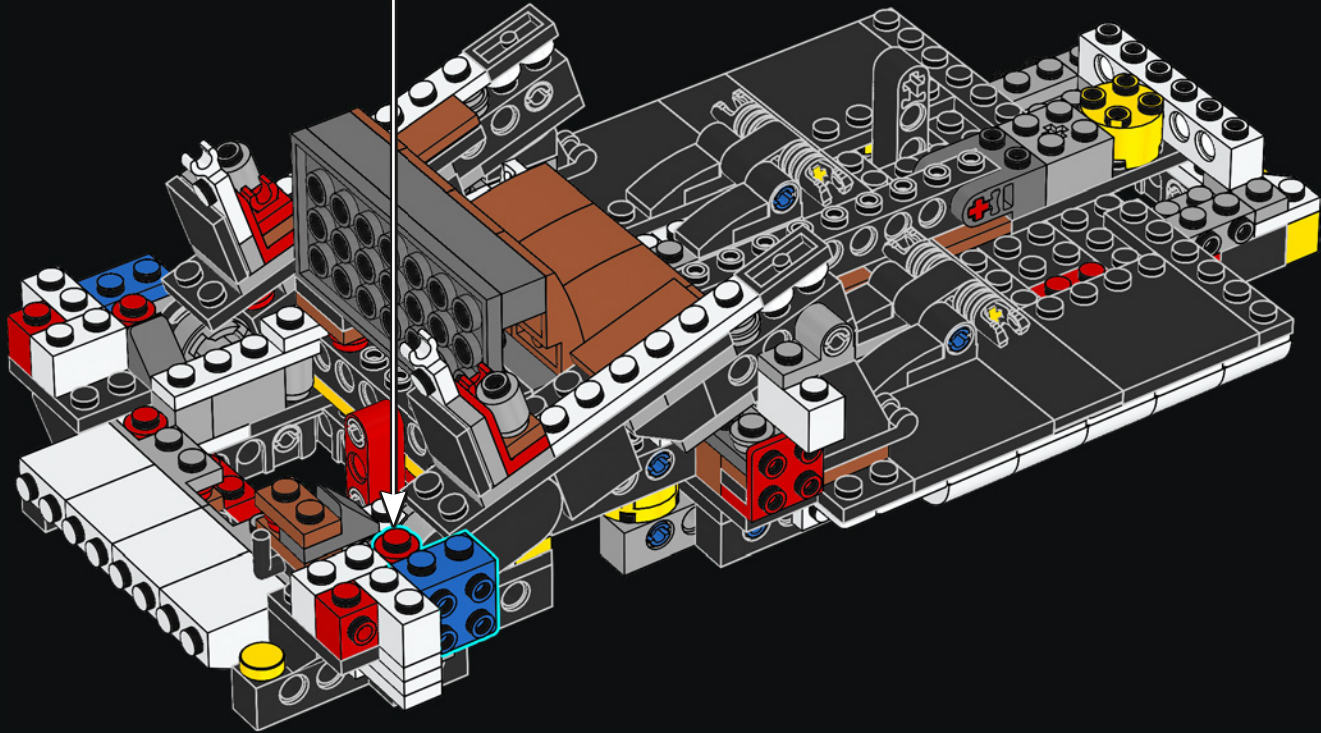
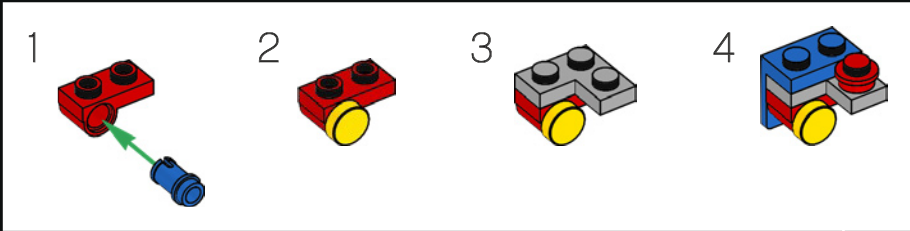



86

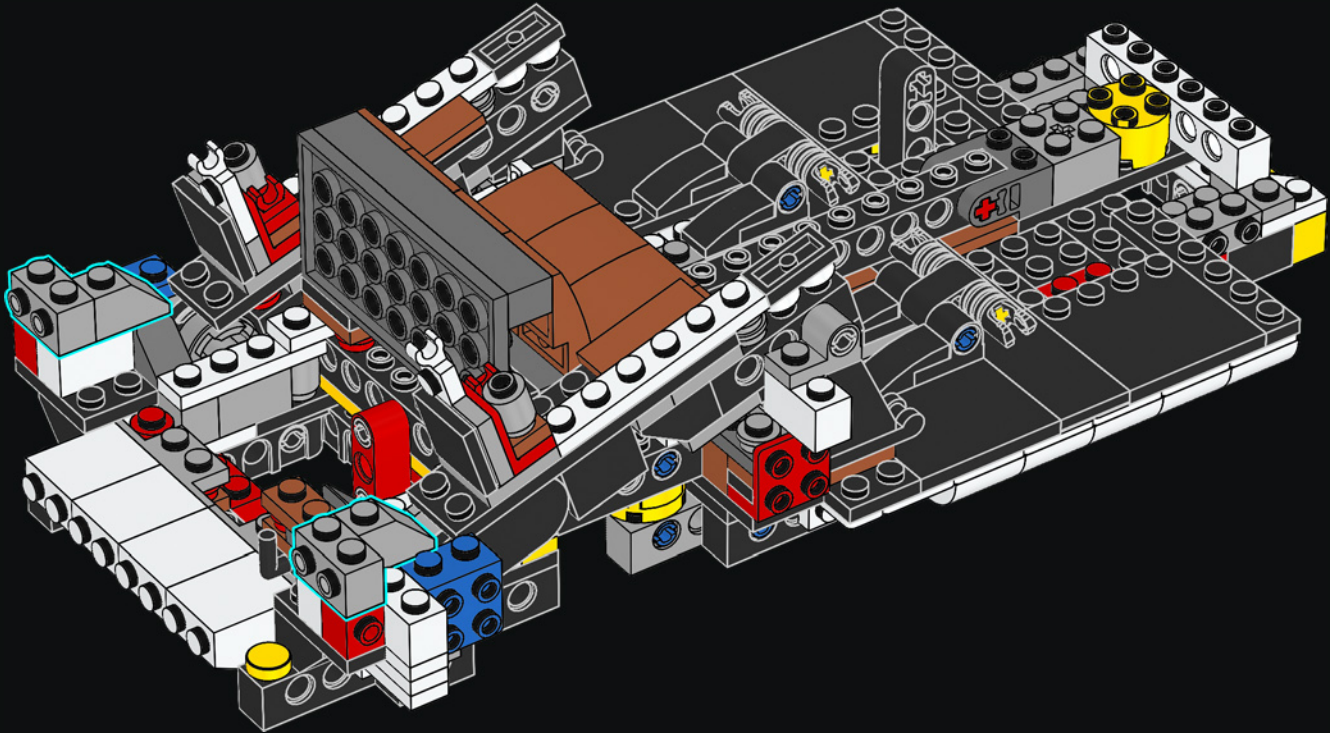



87

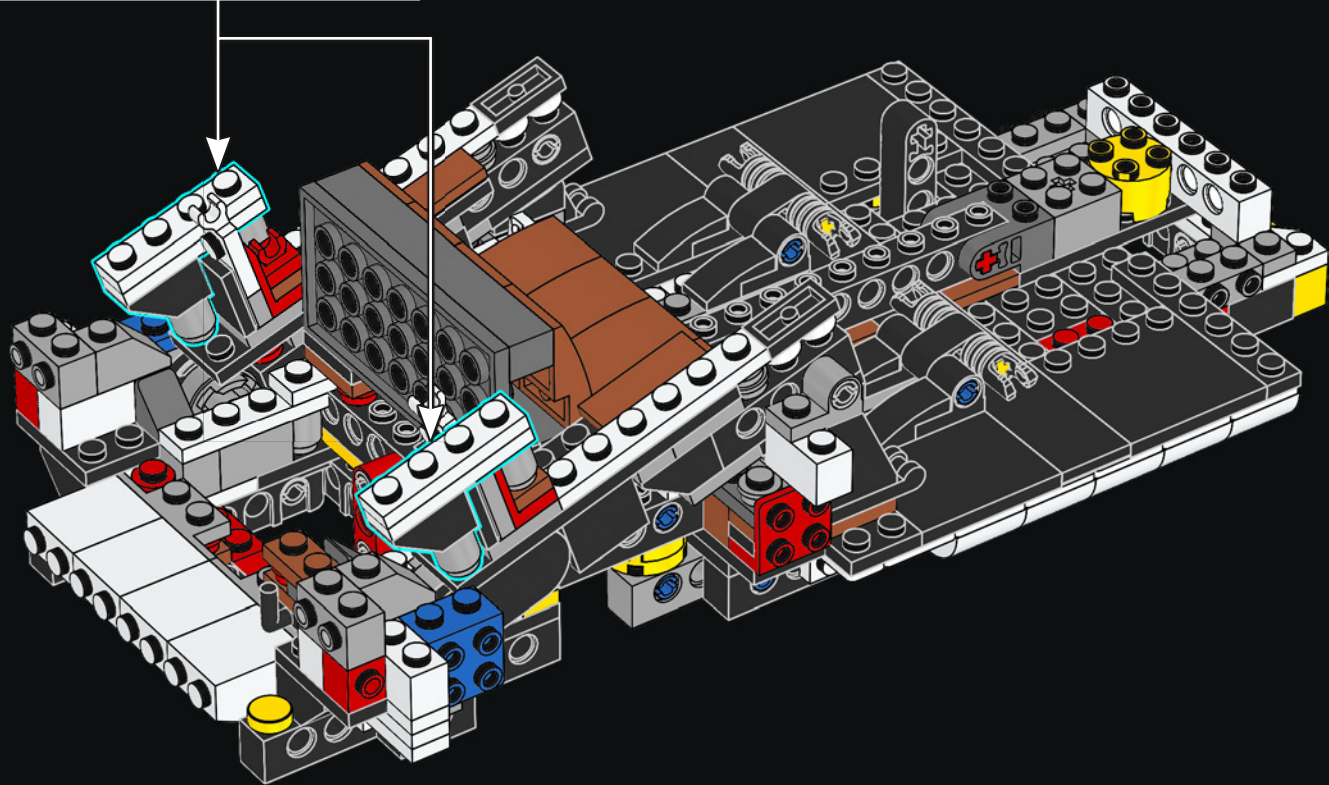
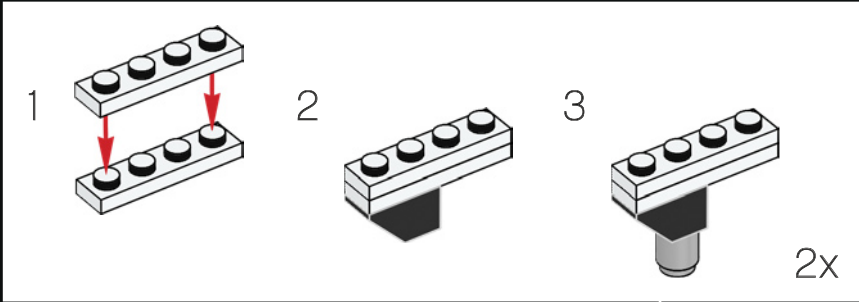

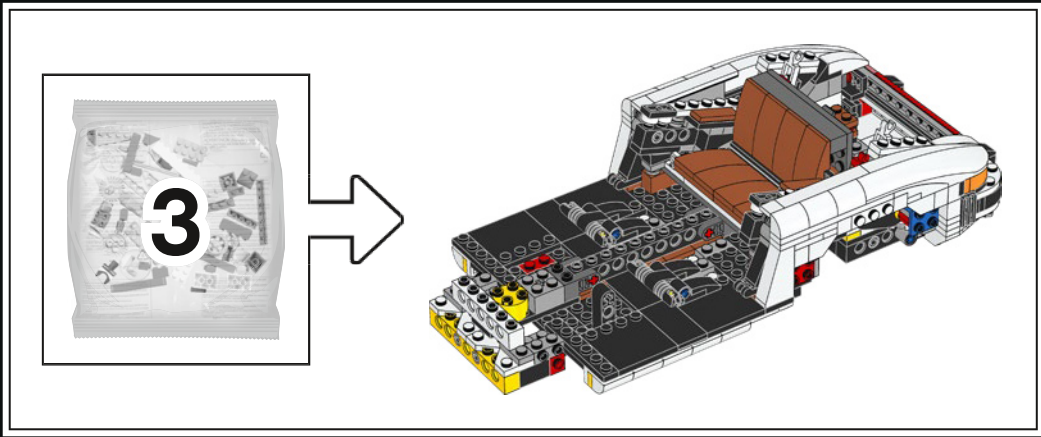

88

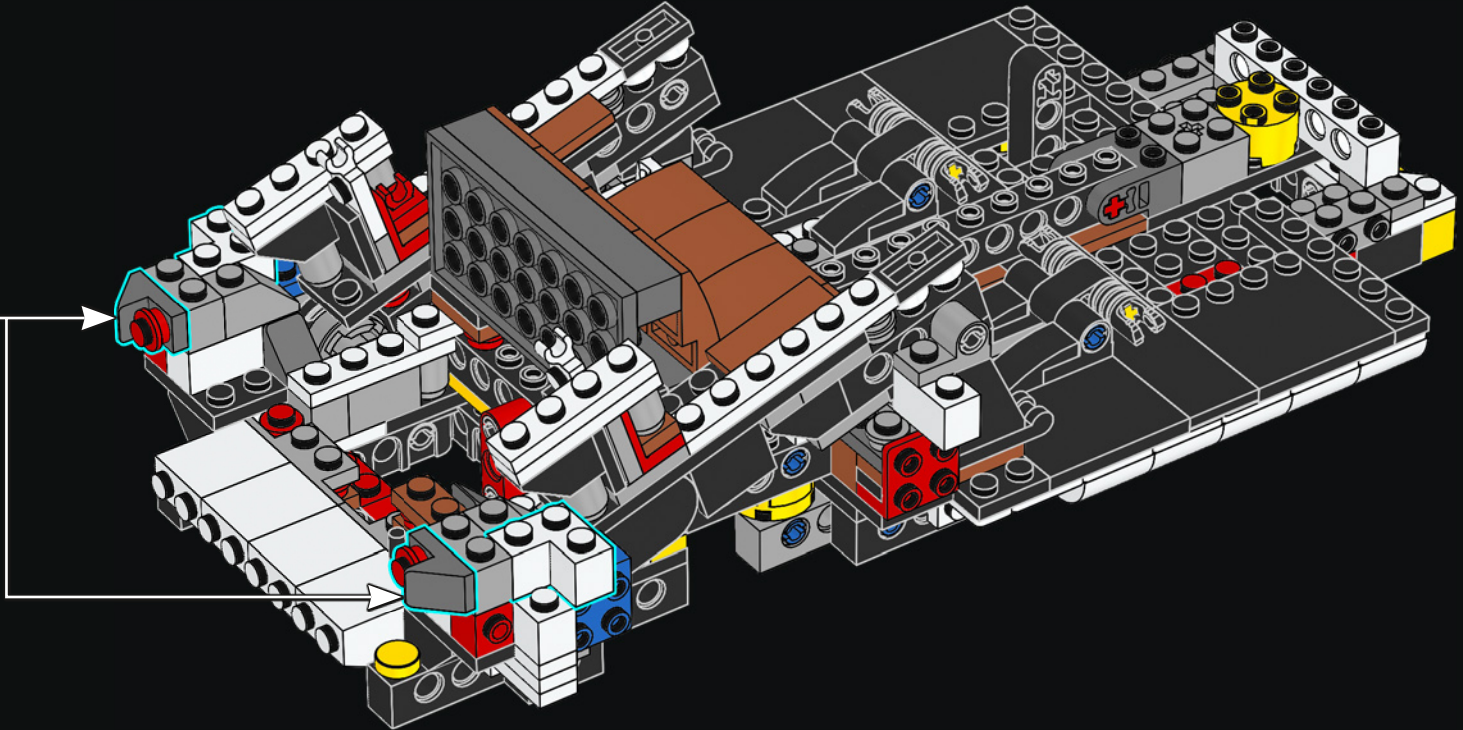
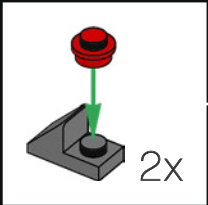

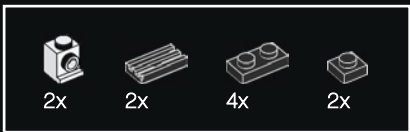

89

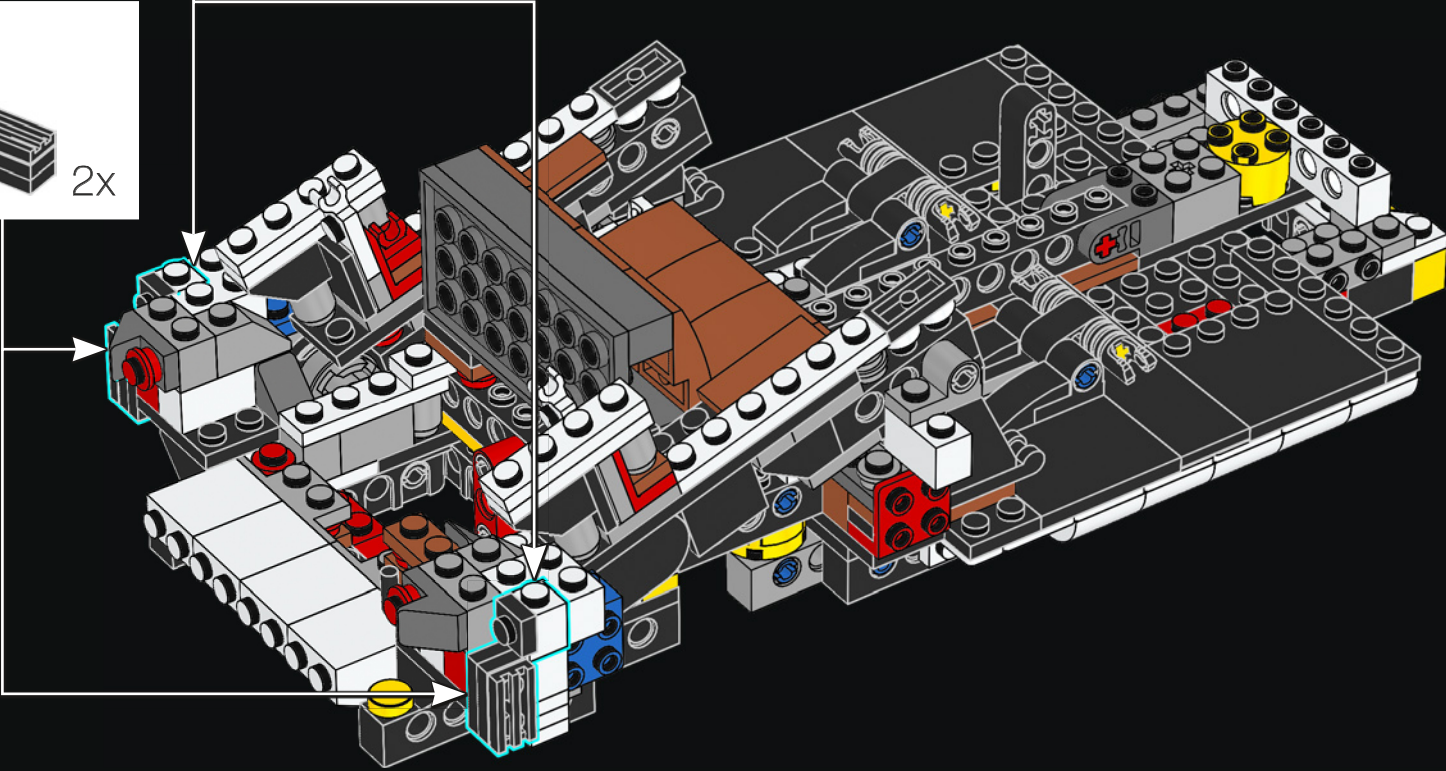
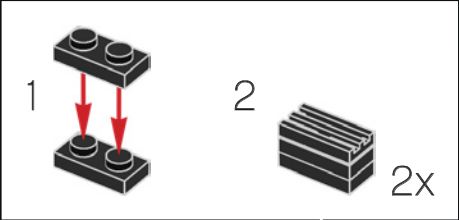
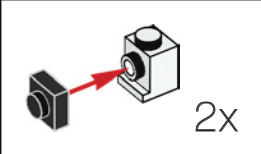

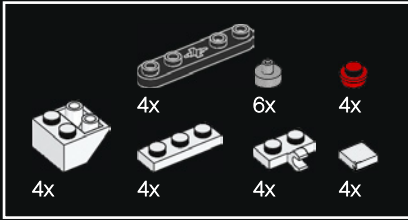
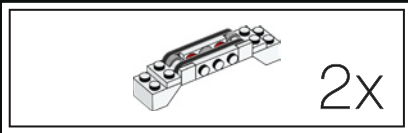

90

1



2

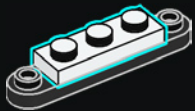

3

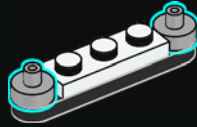

4

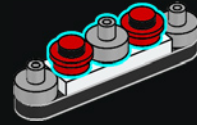

5

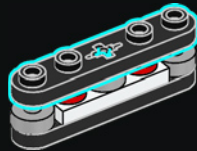

6

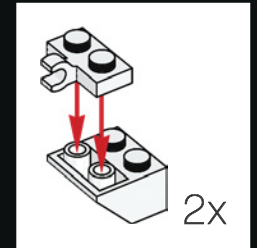
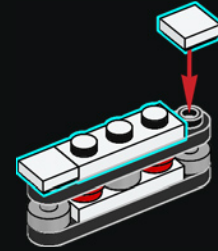

7

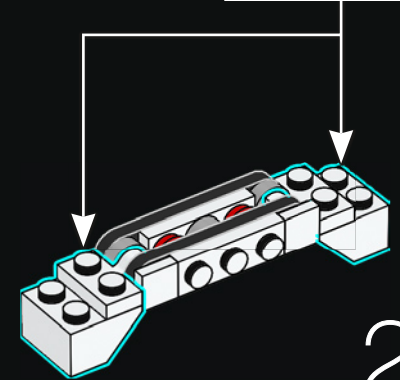

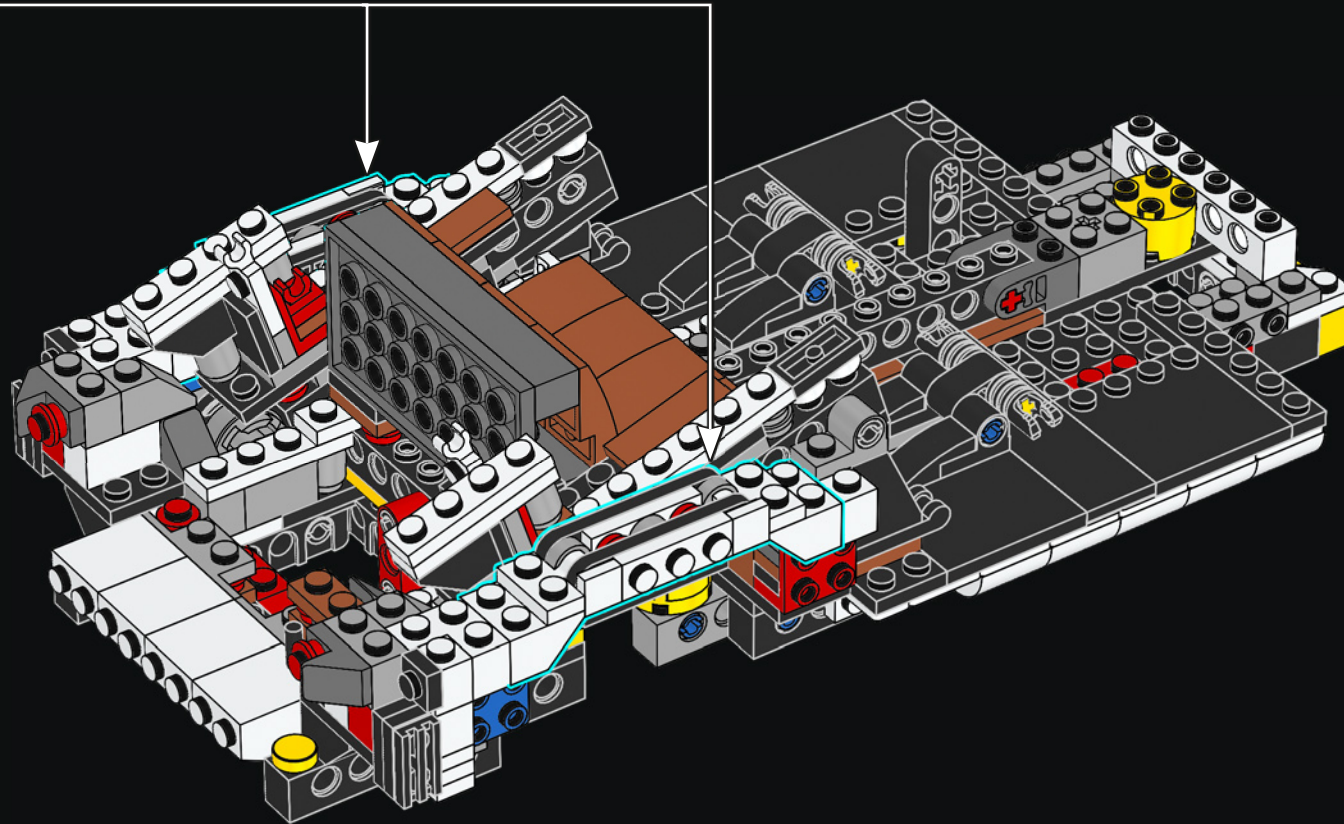



91

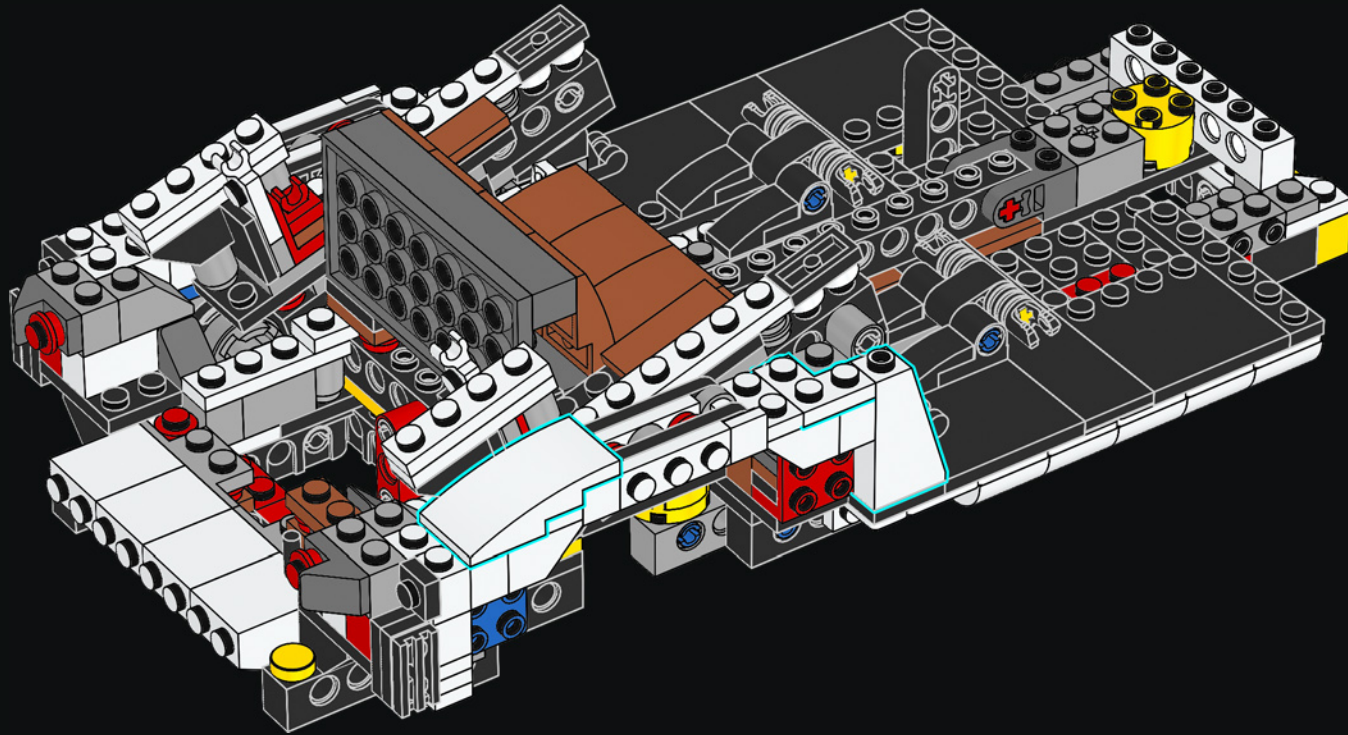

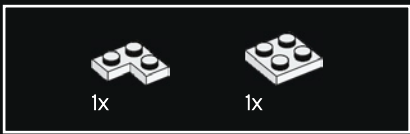

92

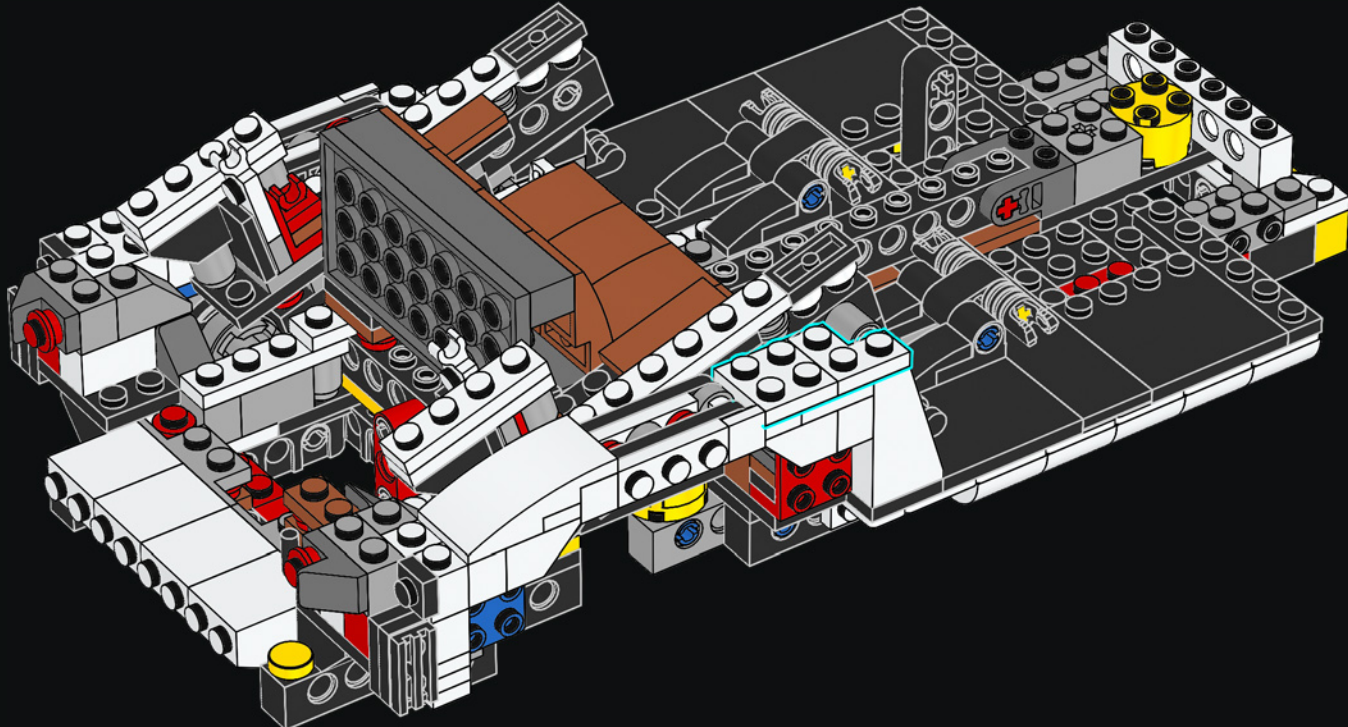



93

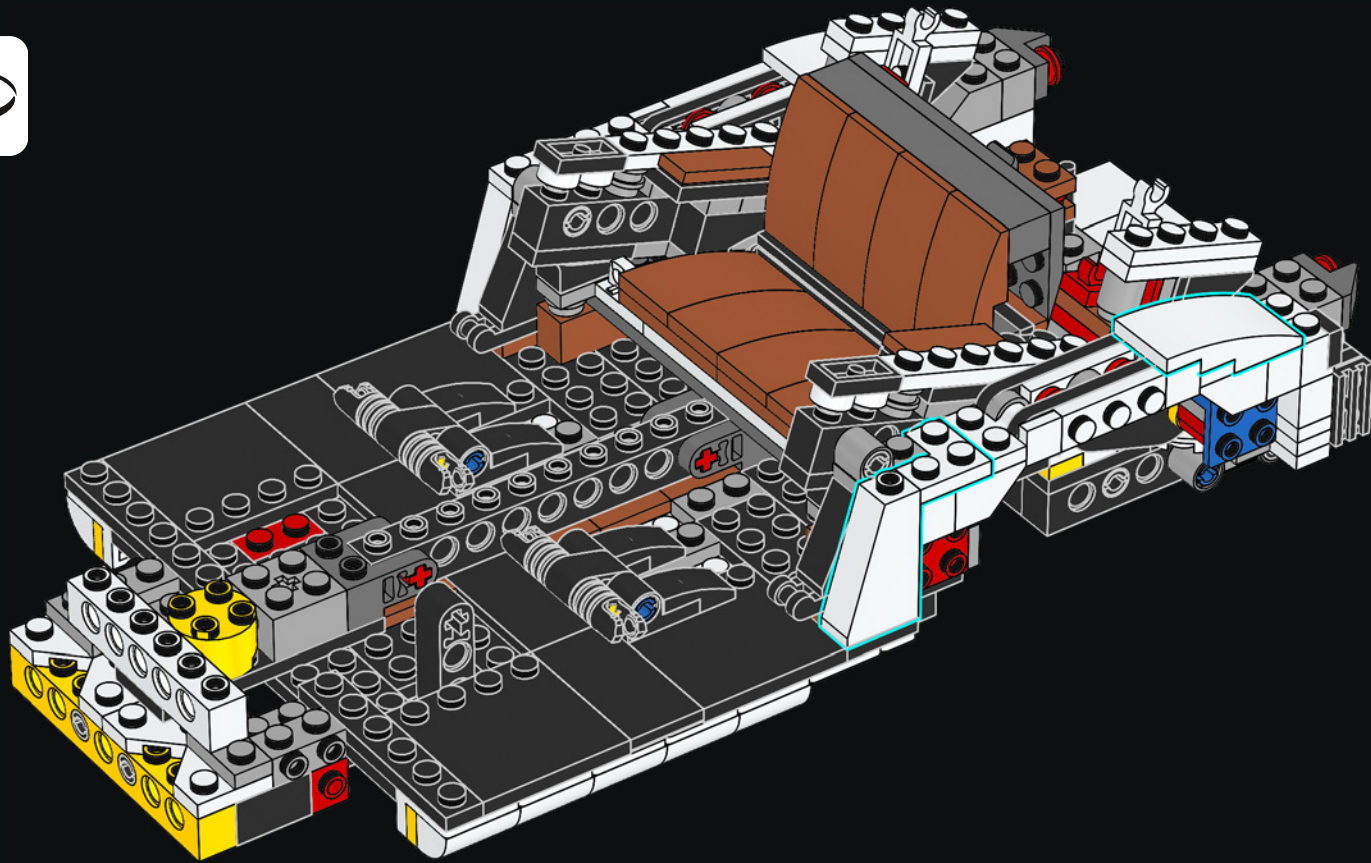

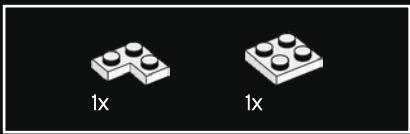

94

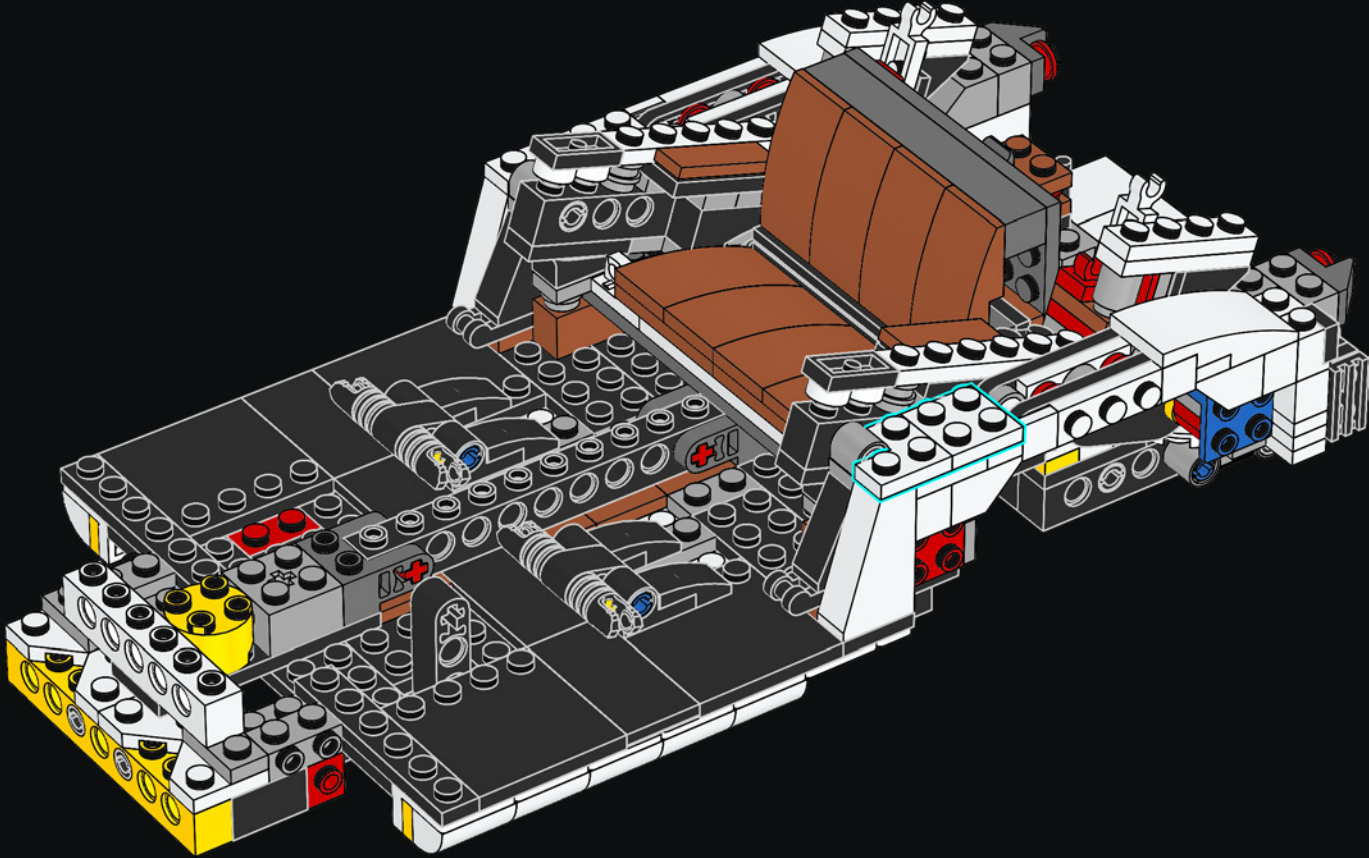

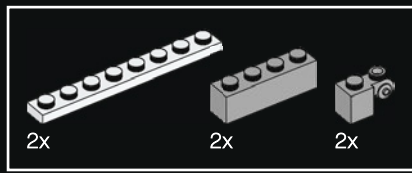

95

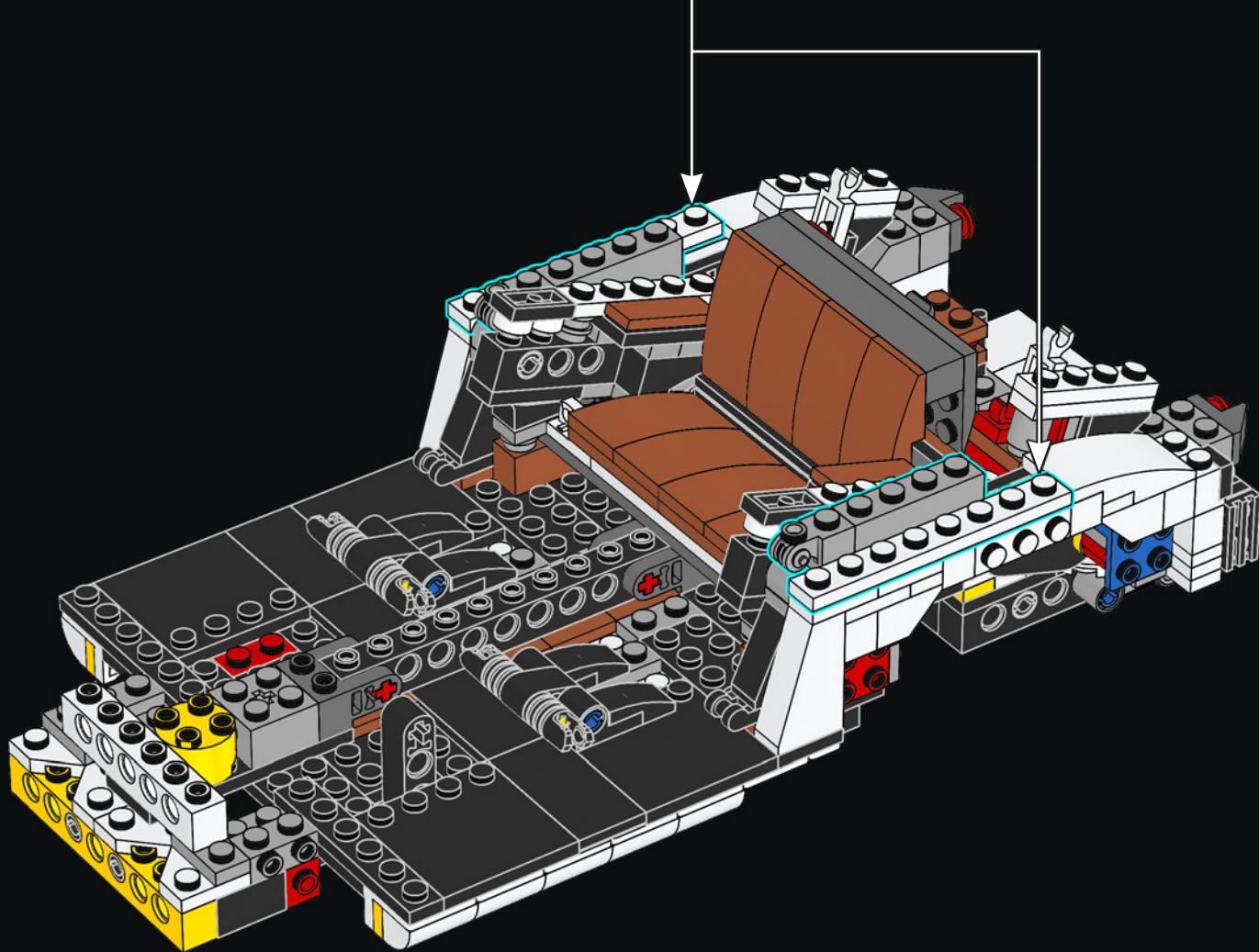
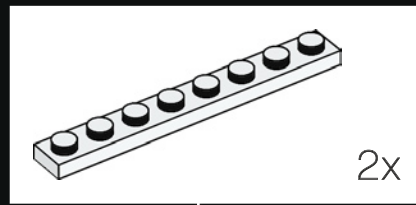

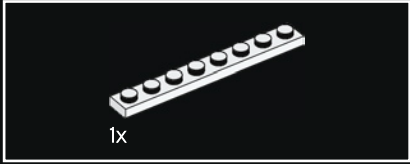
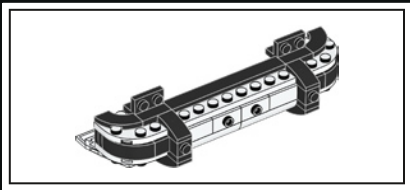

96

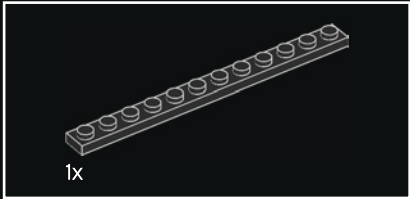
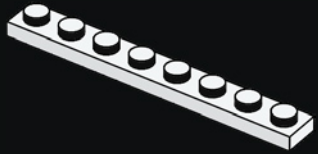

97

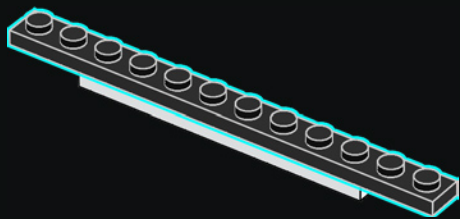

98

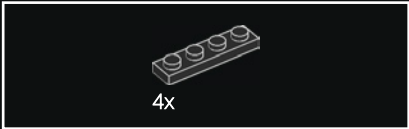
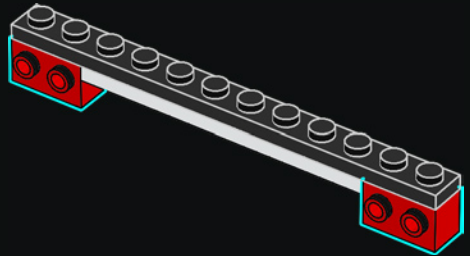

99

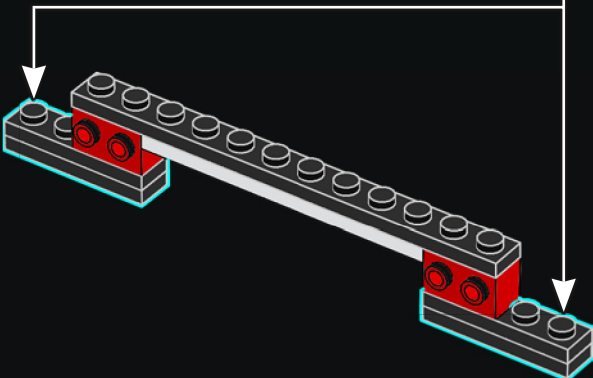
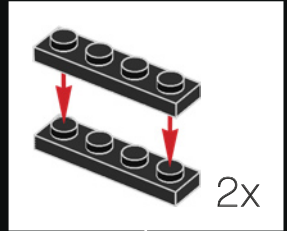



100

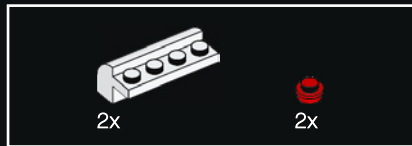
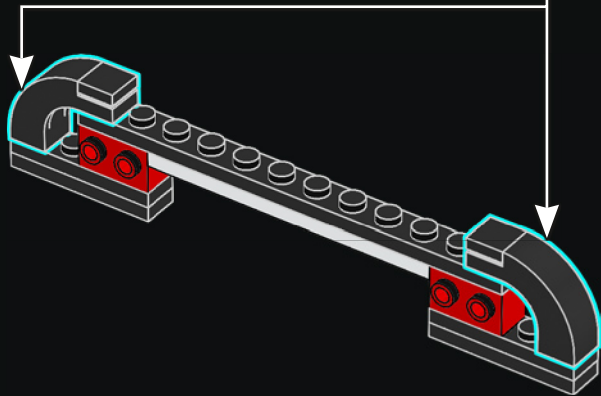
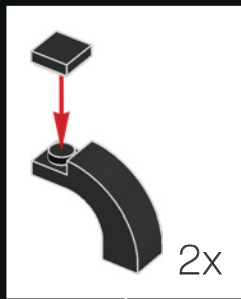

101

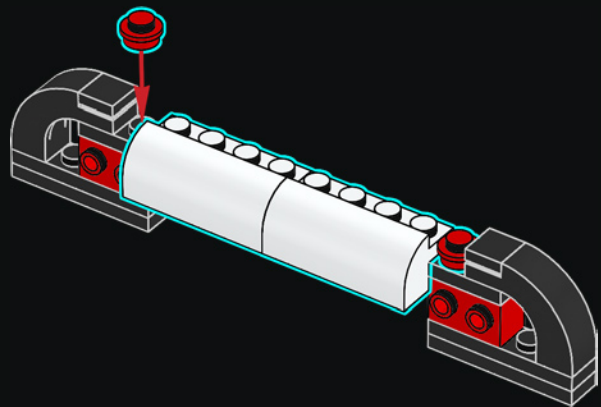

102

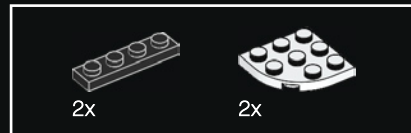
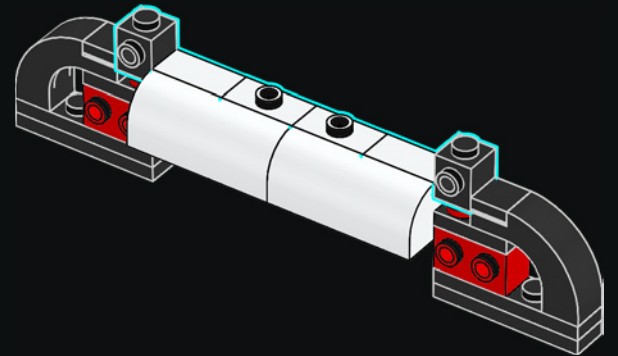

103

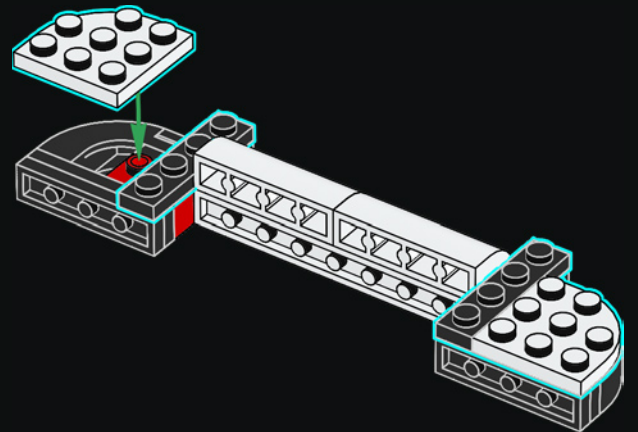

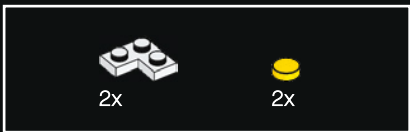

104

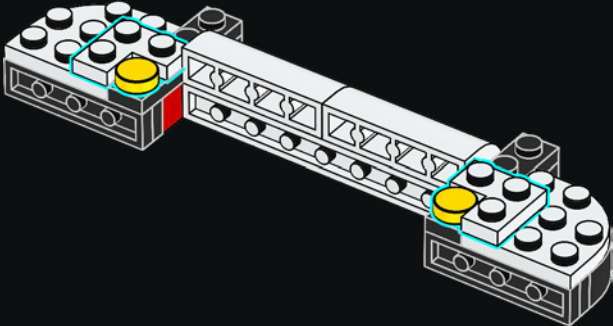

105

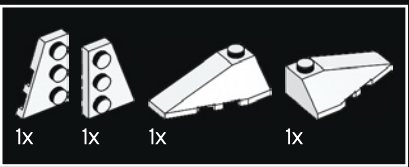
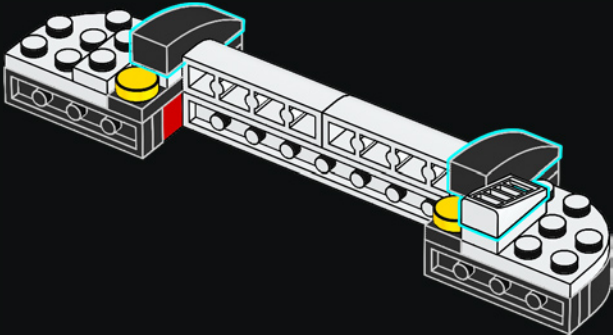

106

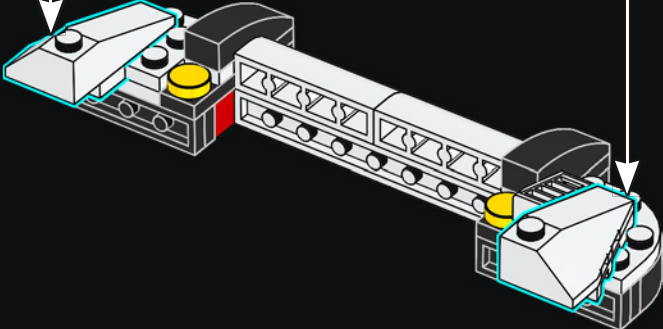
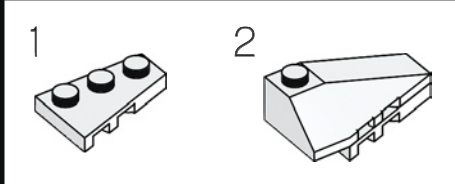
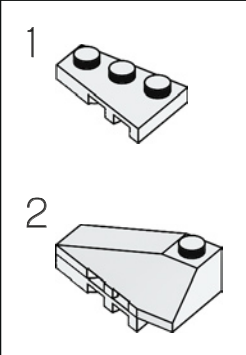

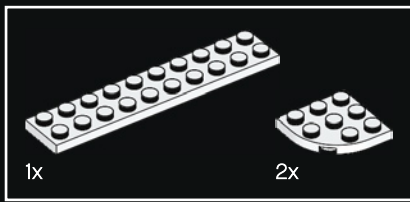

107

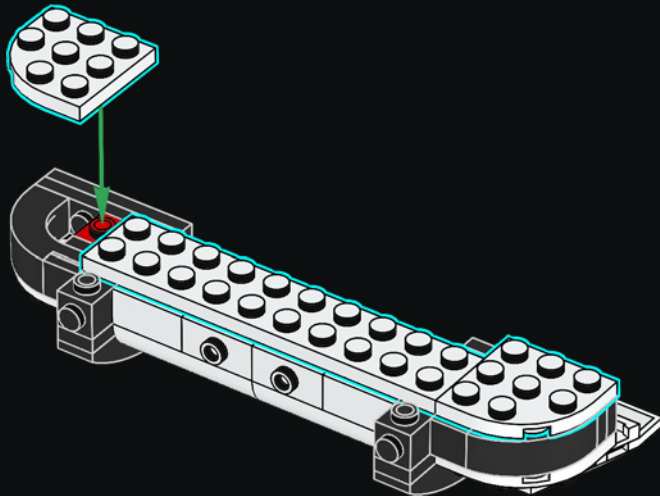

108

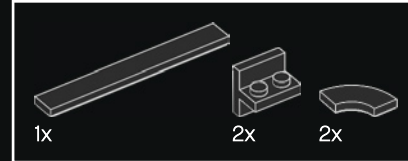
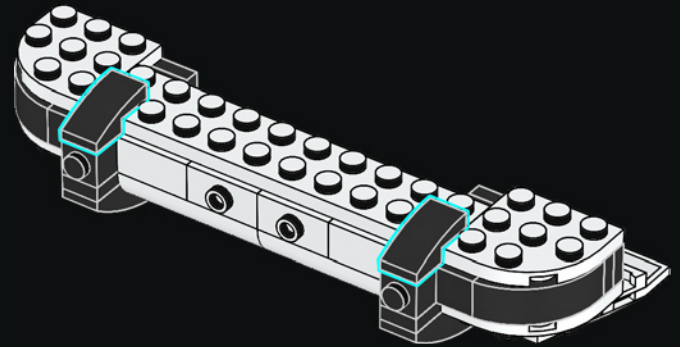

109

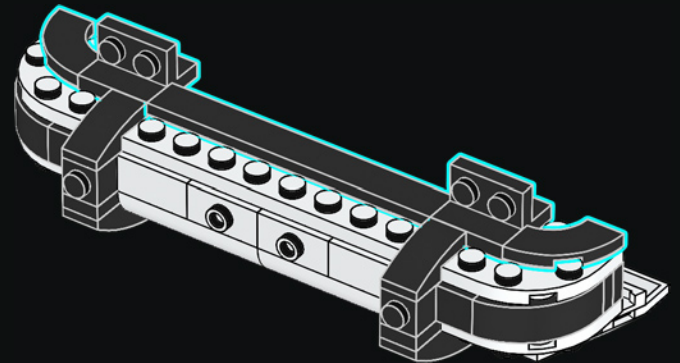

110

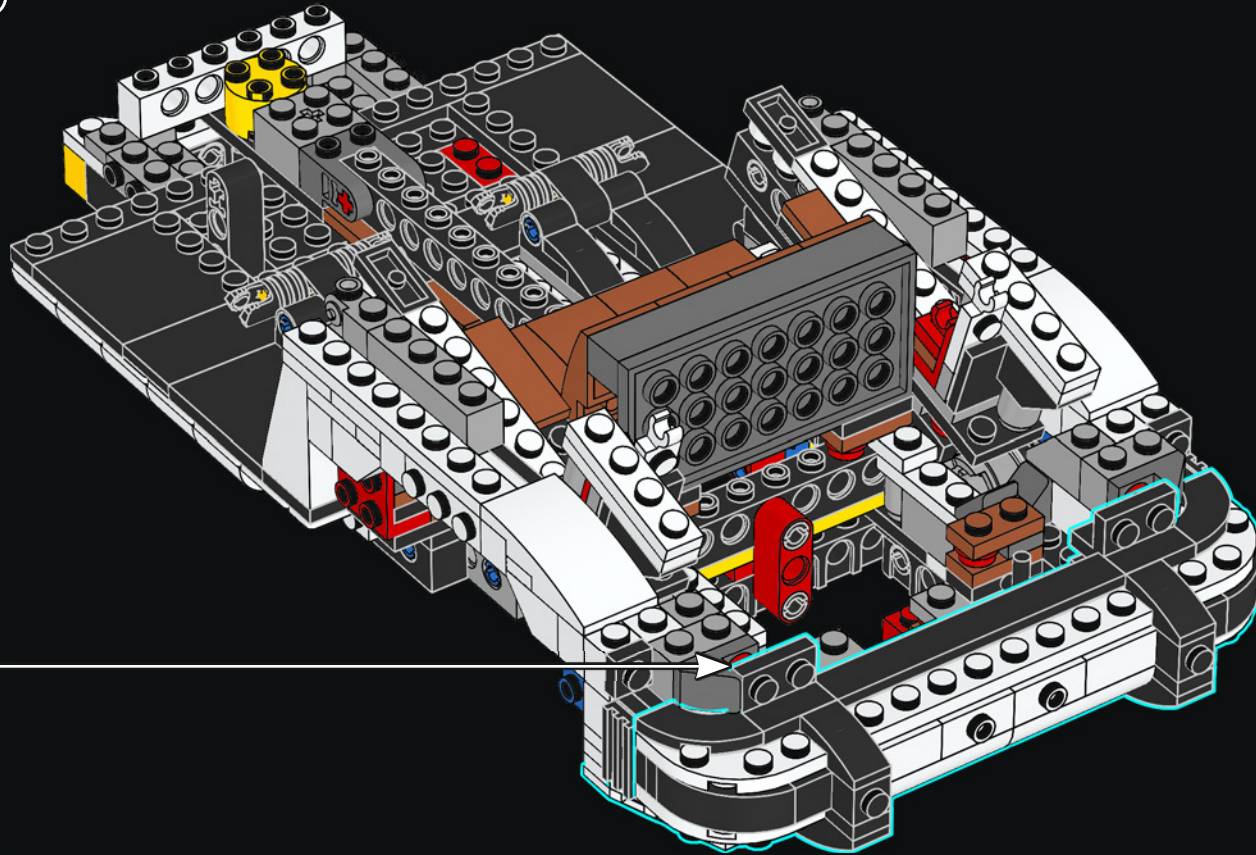

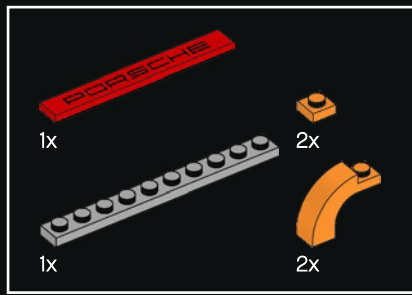

111

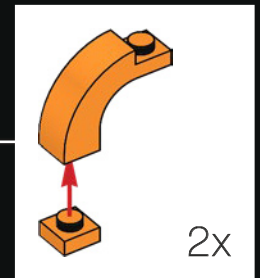
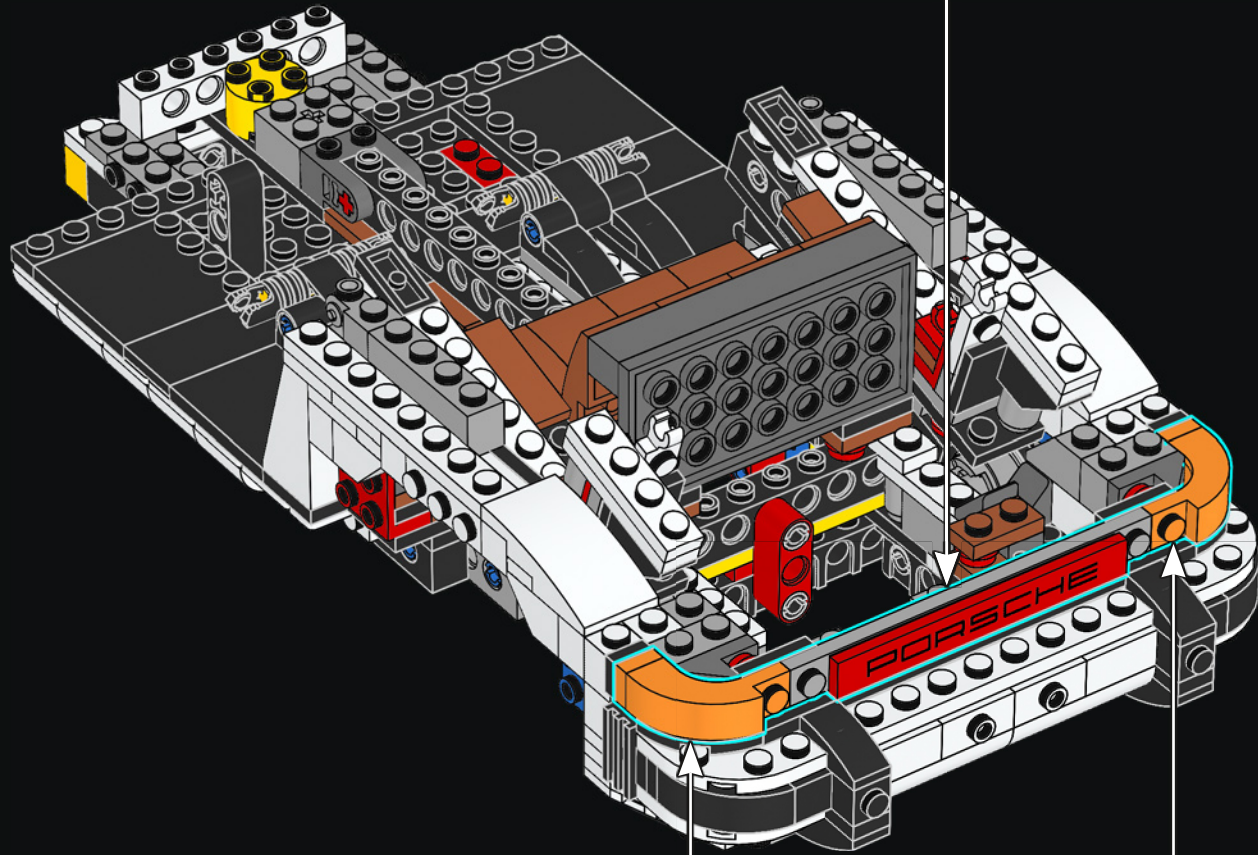
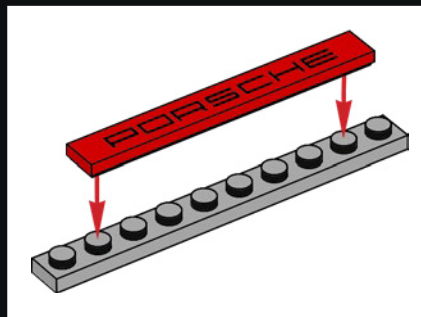

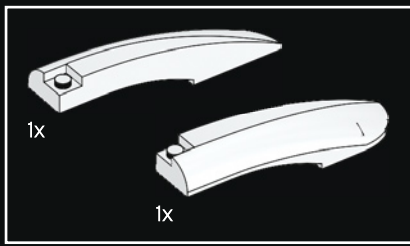

113

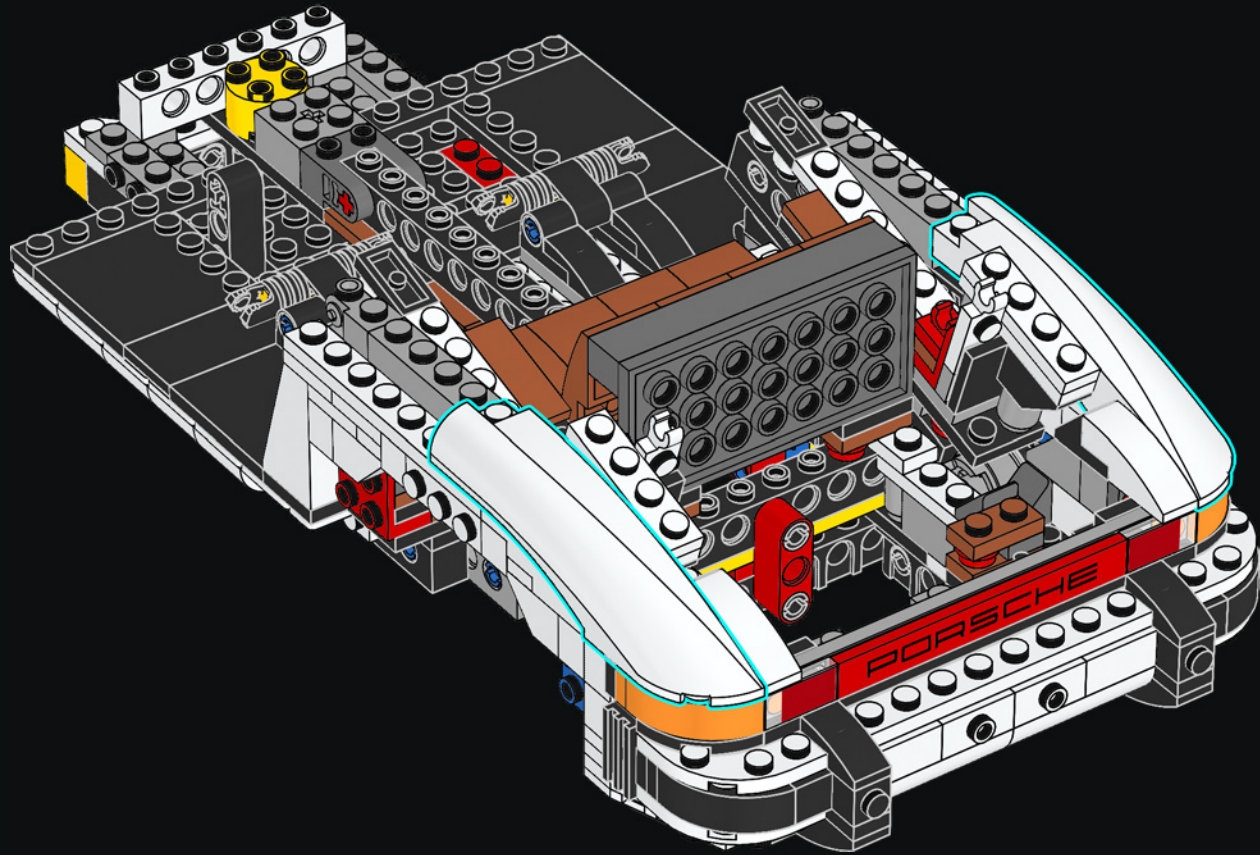



6x

114

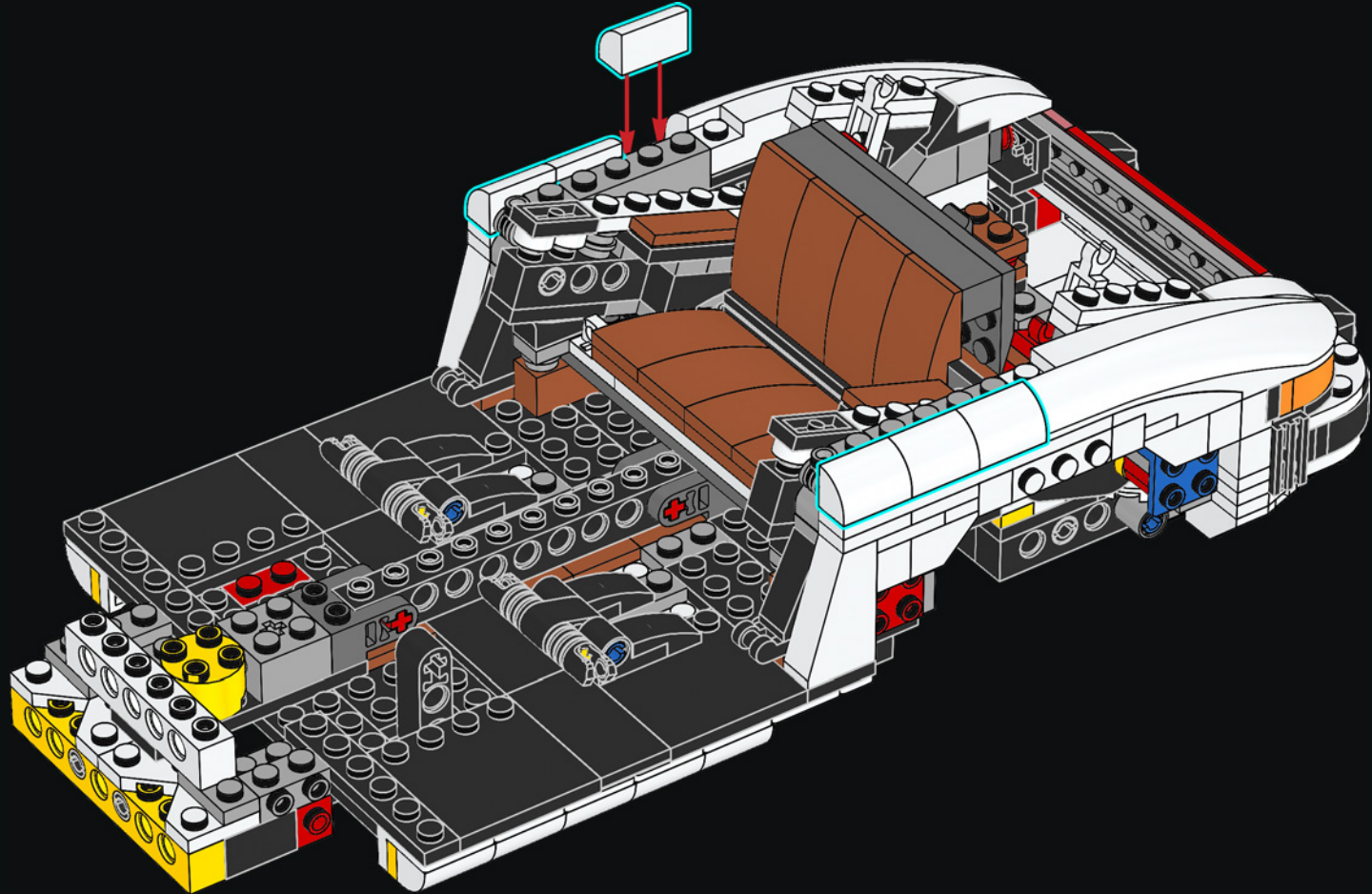



115

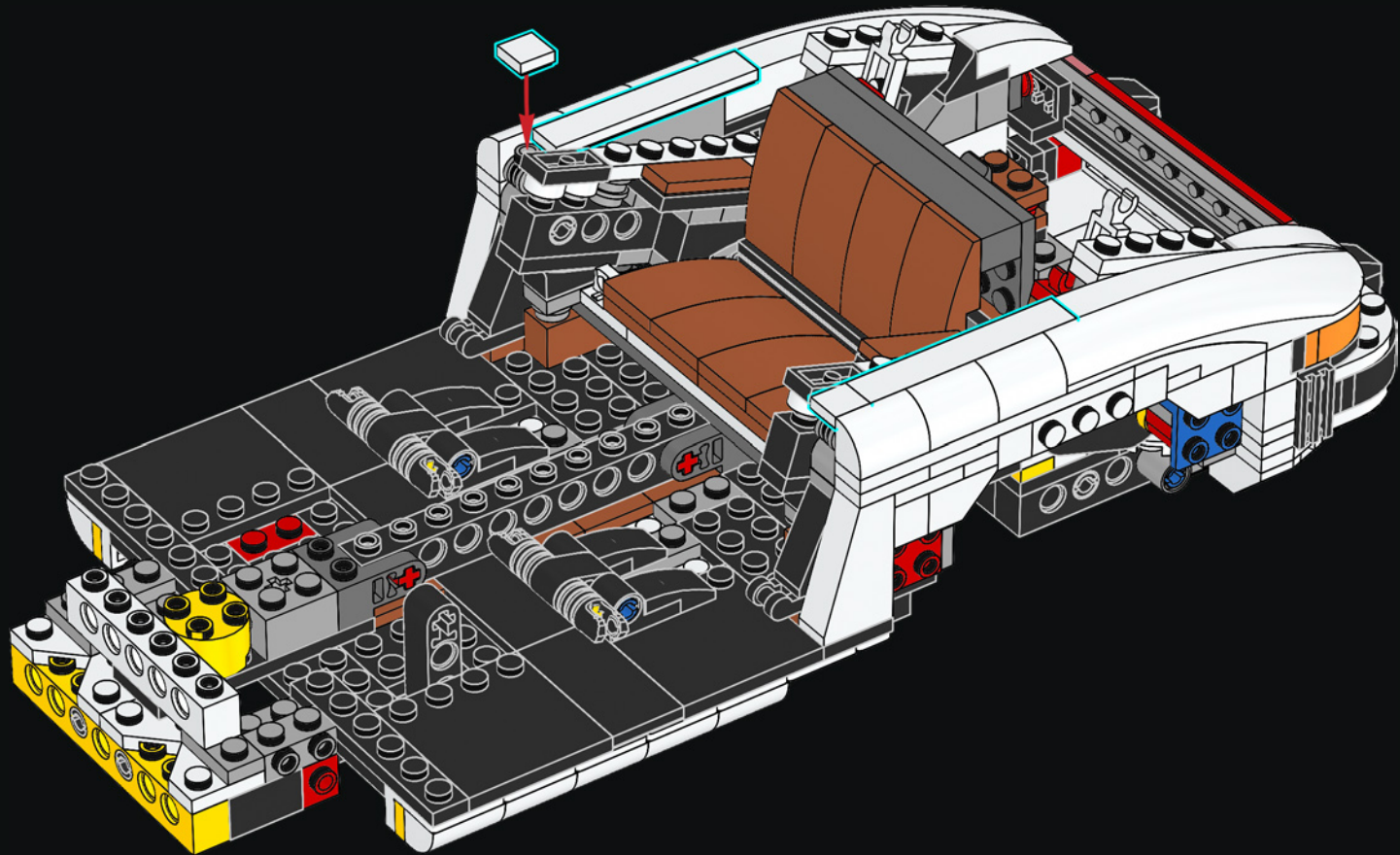



116

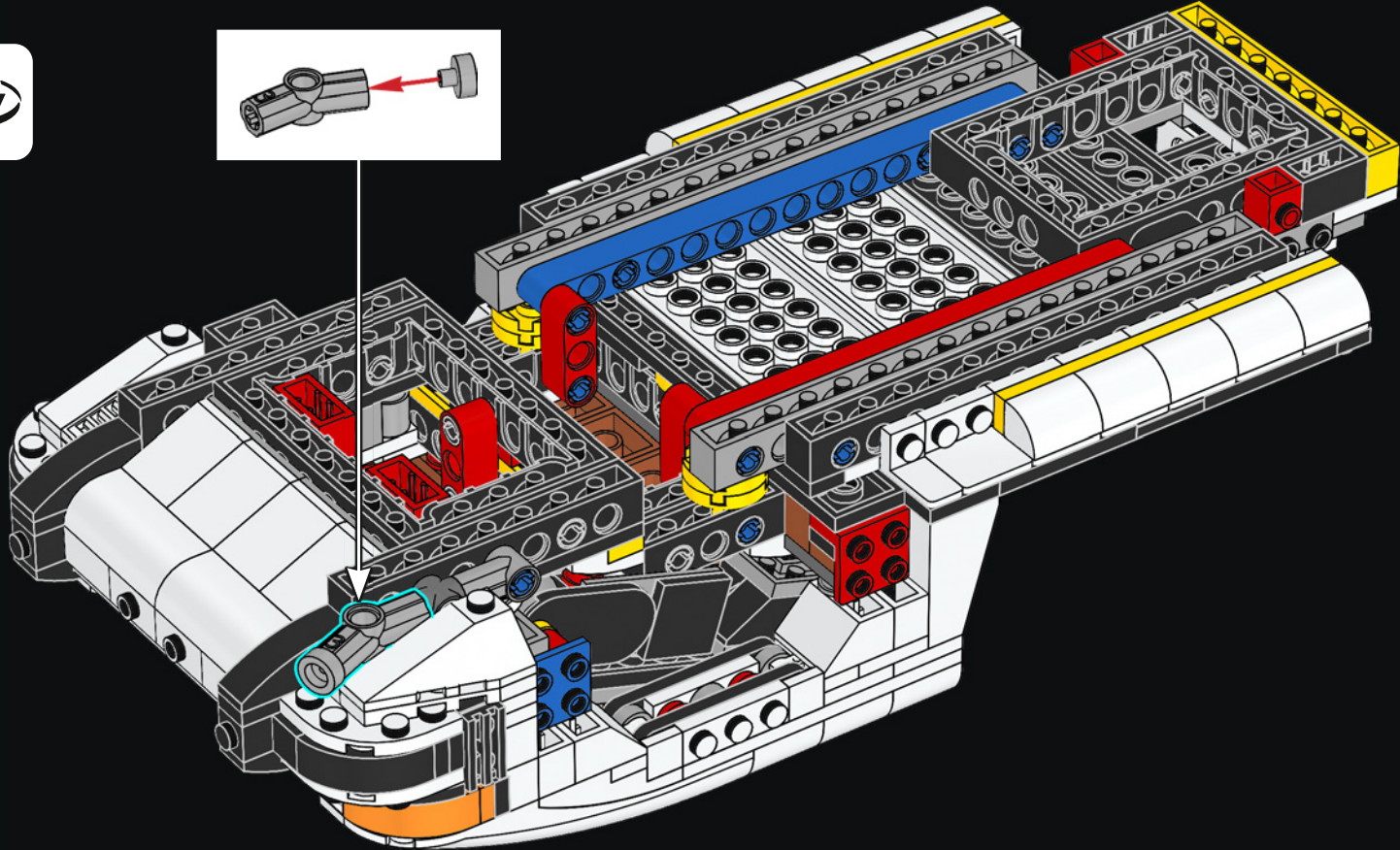
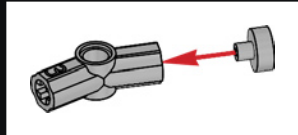

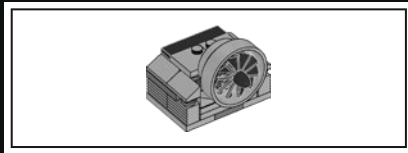
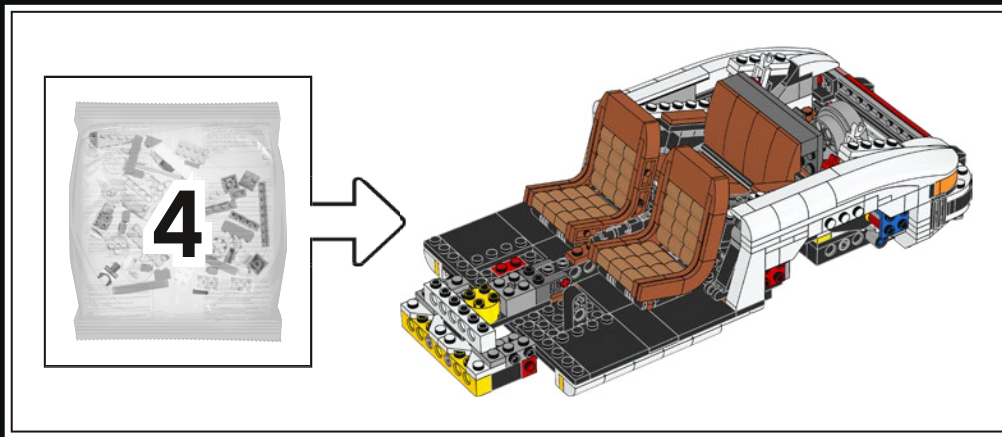

117

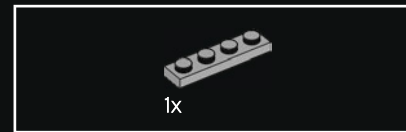

118

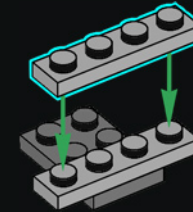

The 911 was born with an air-cooled six-cylinder "boxer" engine.

Der 911 kam ursprünglich mit einem luftgekühlten 6-Zylinder-Boxermotor auf den Markt.



119

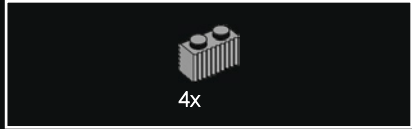
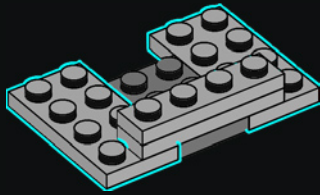

120

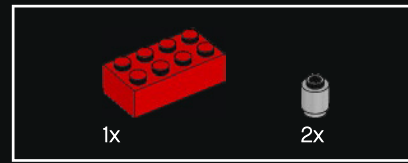
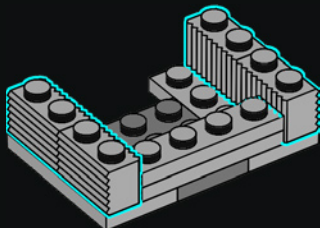

121

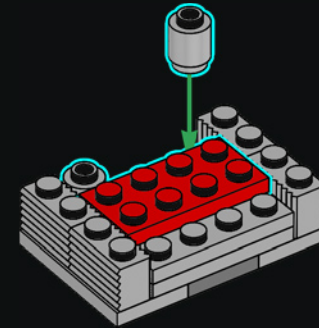

The heart of the "boxer" engine is a red 2x4 brick, the heart of the LEGO® building system.

Das Herz des Boxermotors ist ein roter 2x4 Stein, das Herz des LEGO® Bausystems.

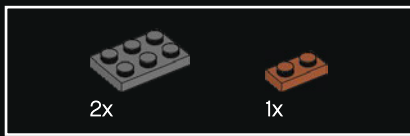

122

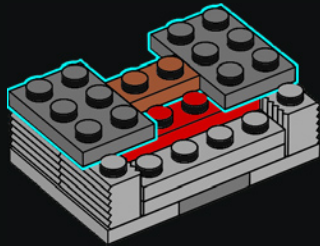

123

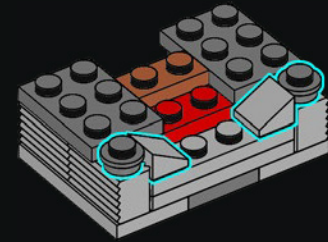

124

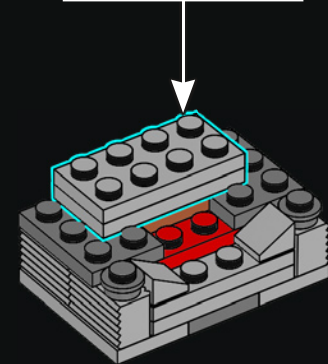
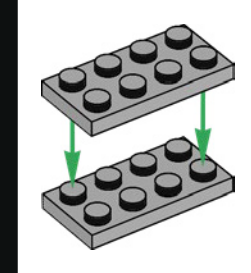



125

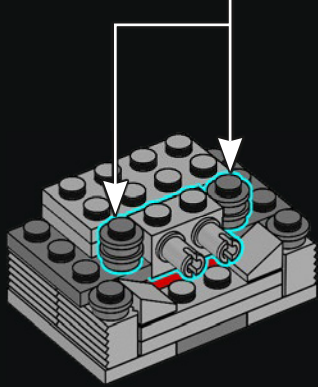
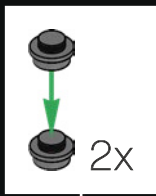

126

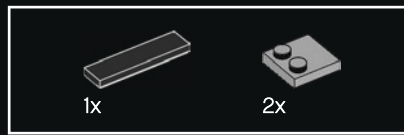
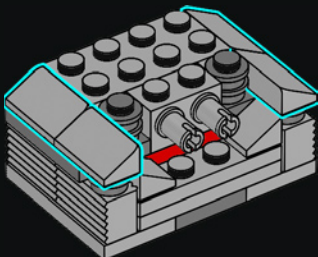

127

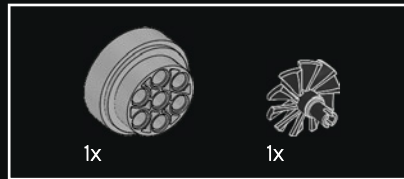
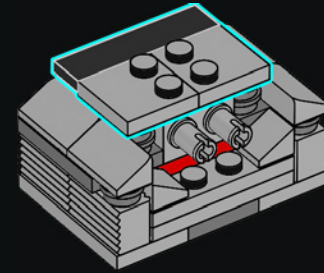

128

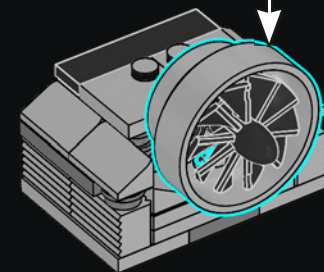
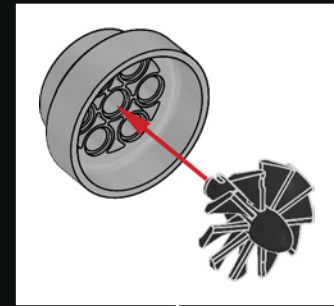

129

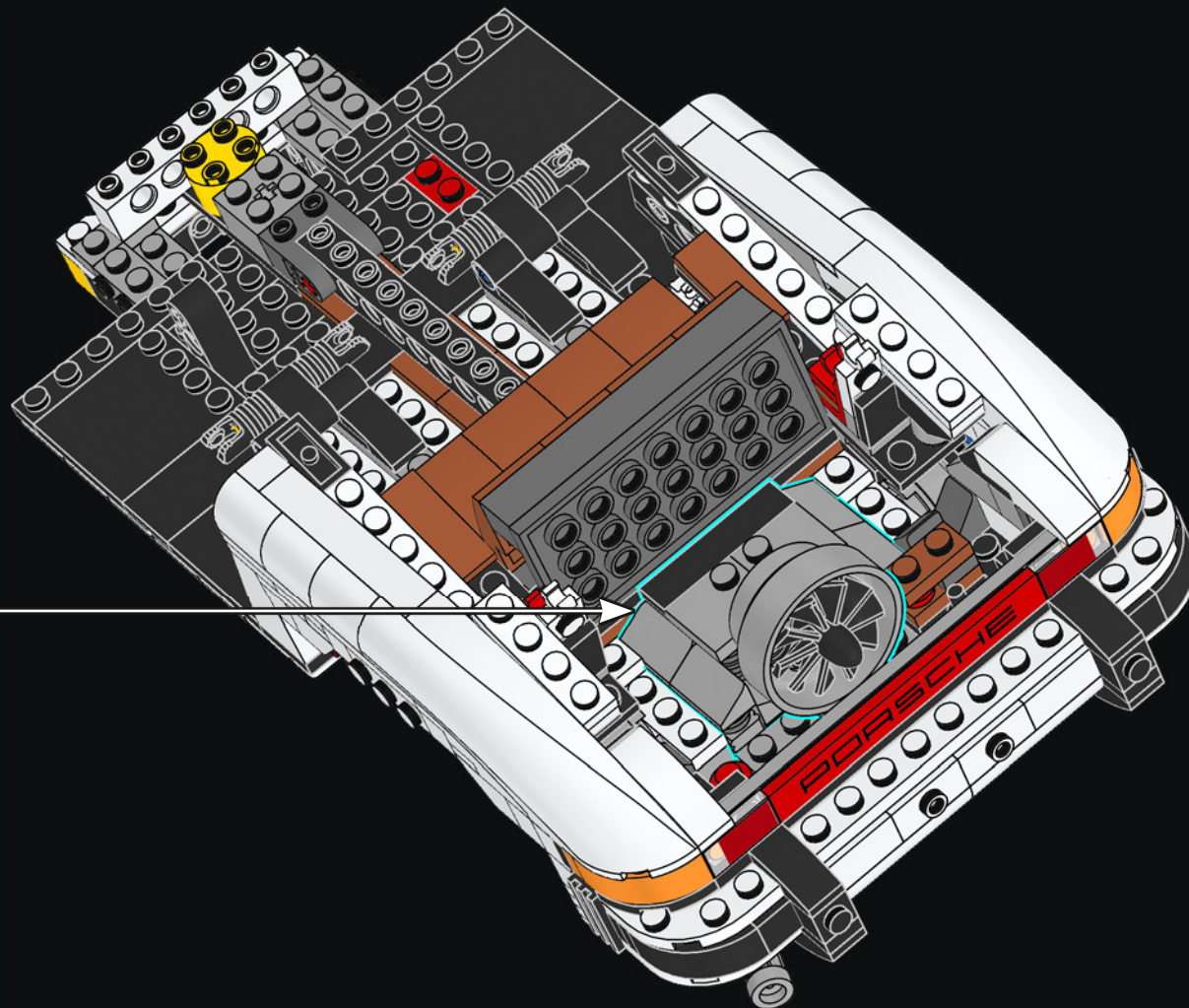

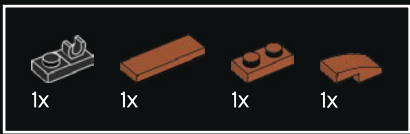

130

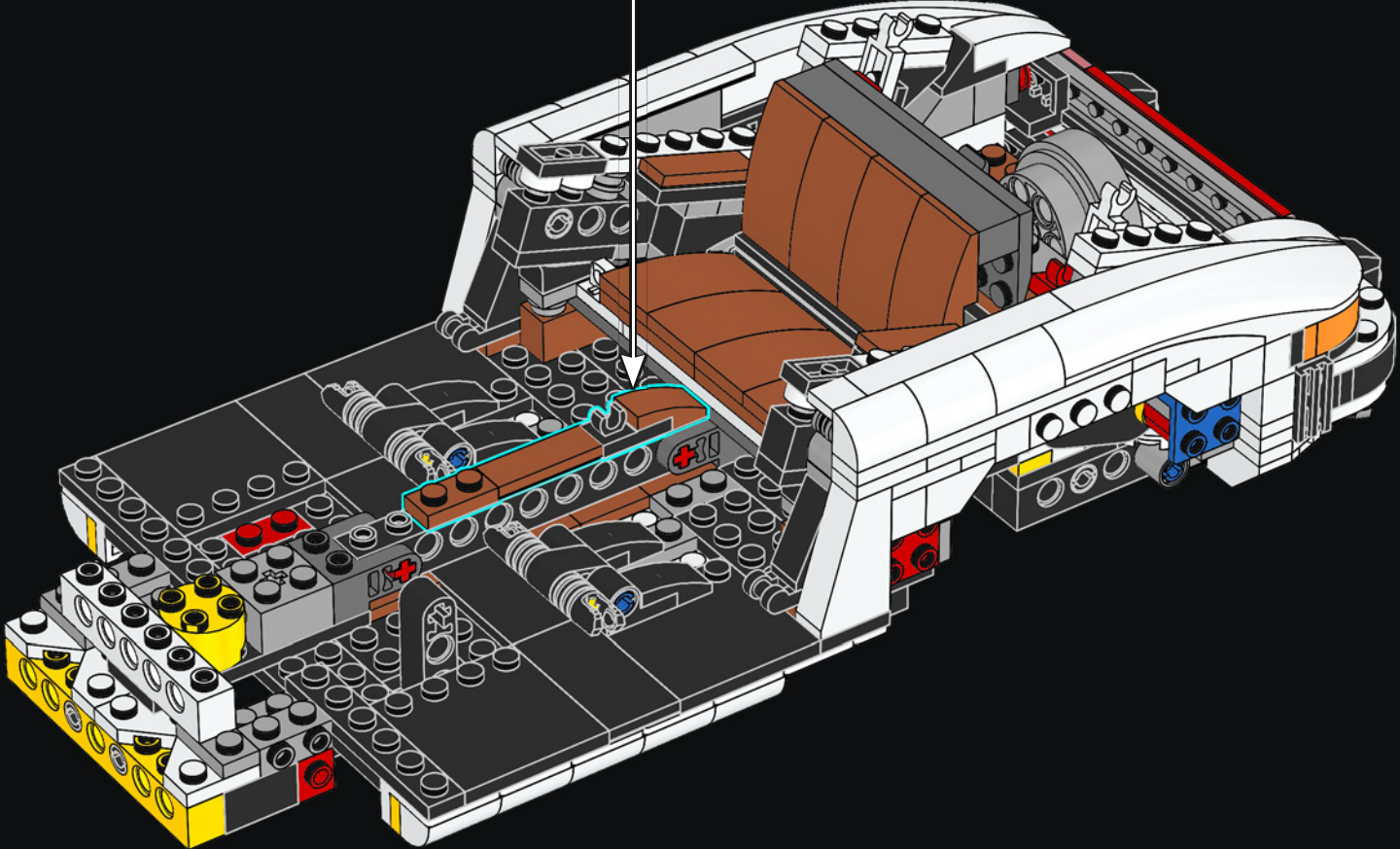
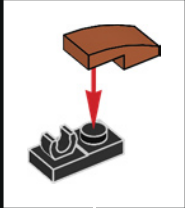



131

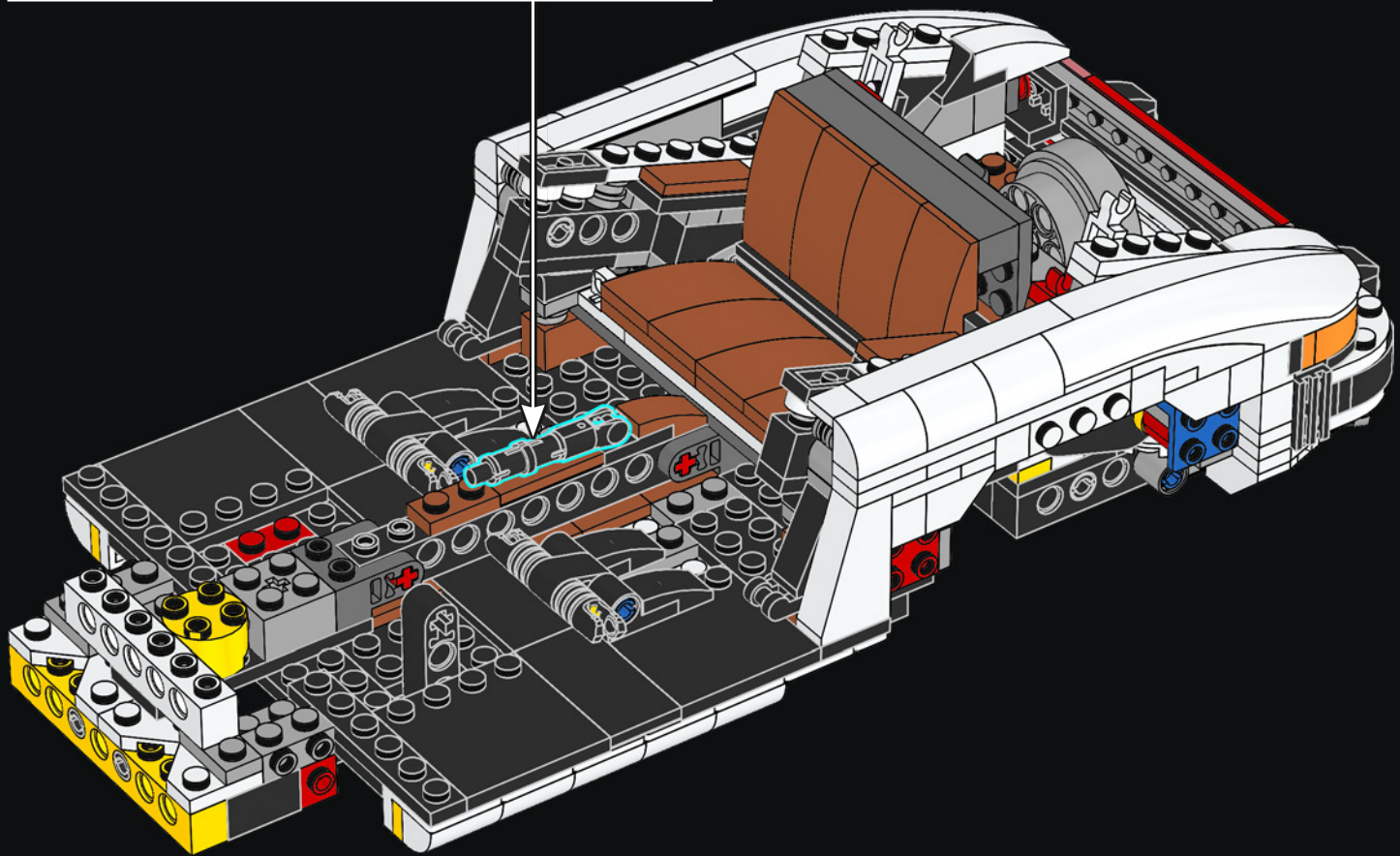
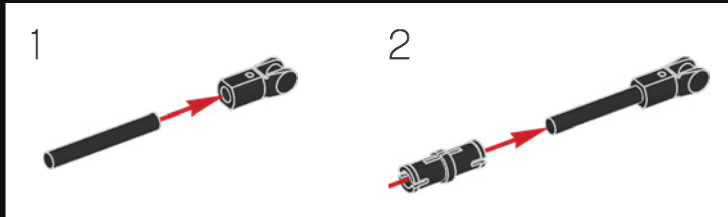



132

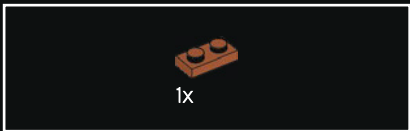
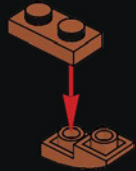

133

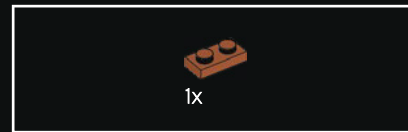

134

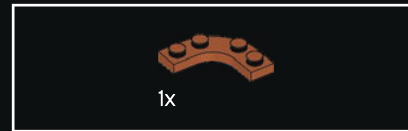
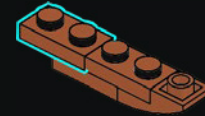

135



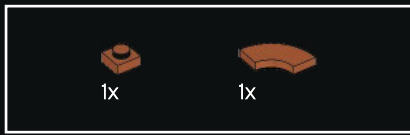

136

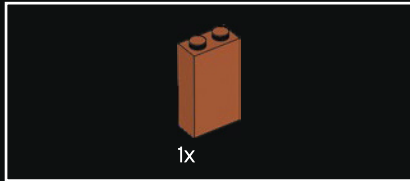
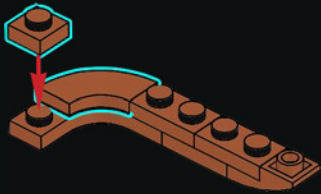

137

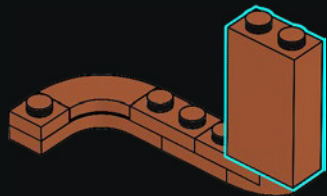

138

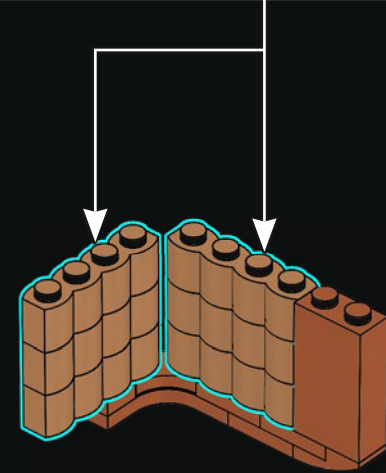
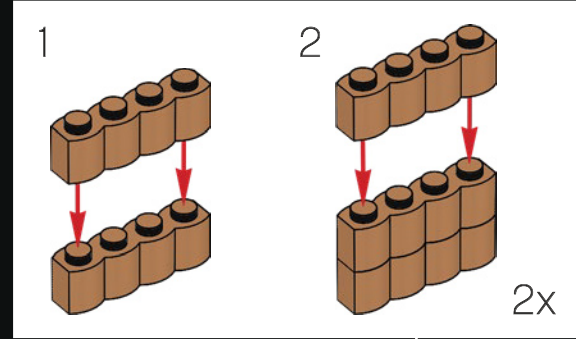



139

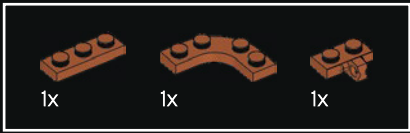
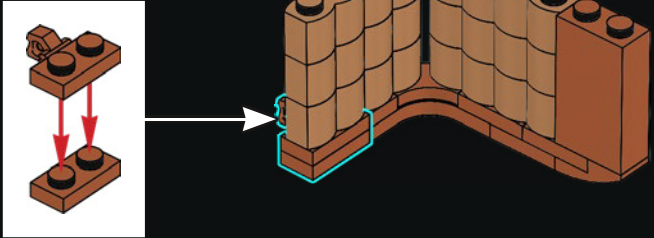

140

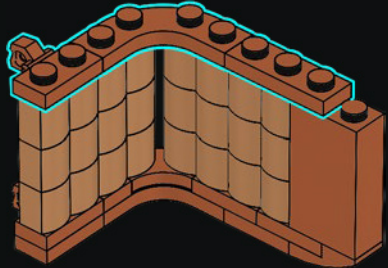

141

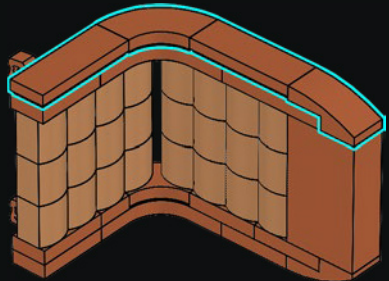

142

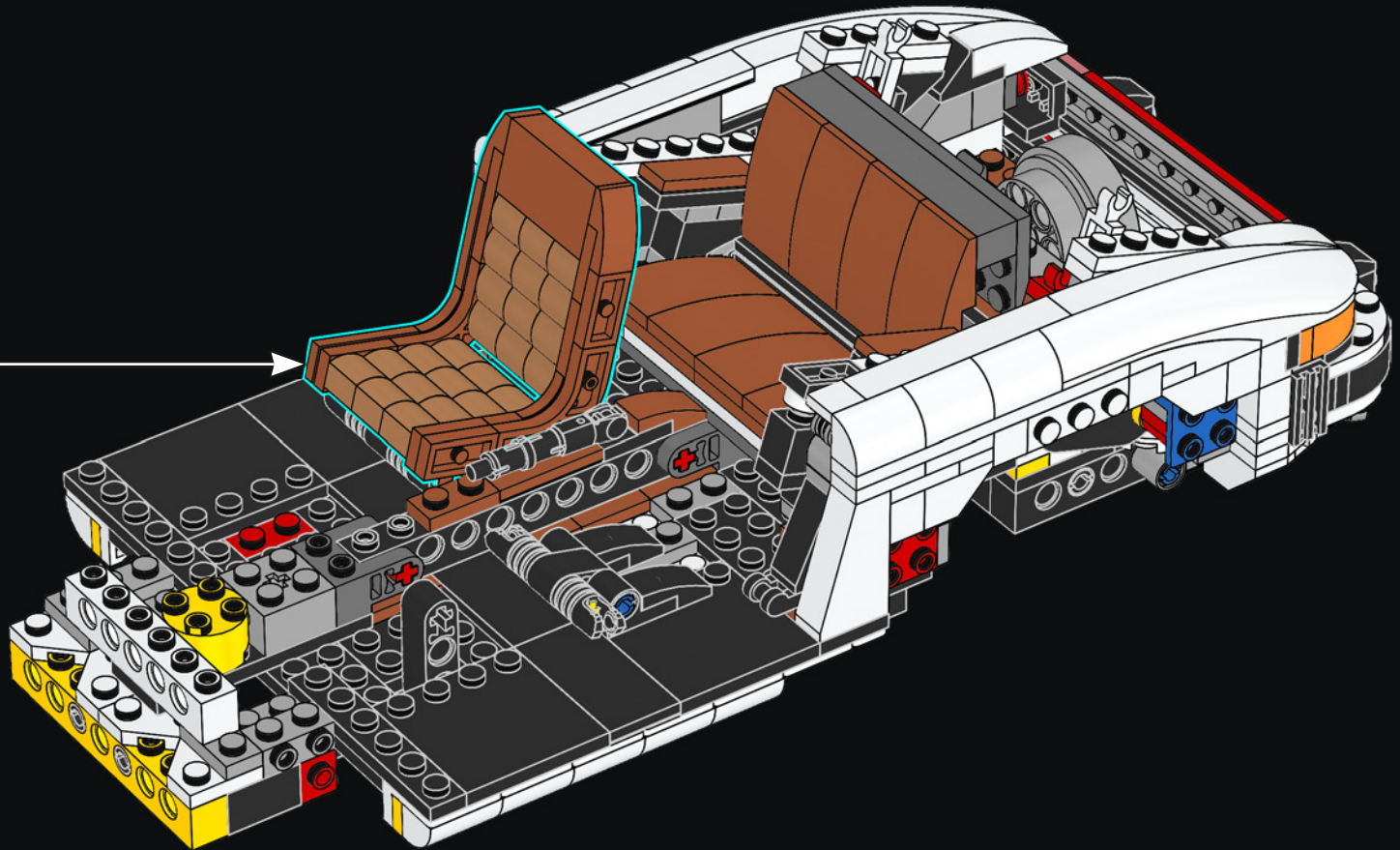

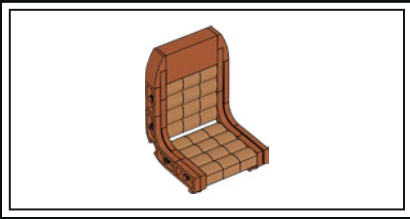

143

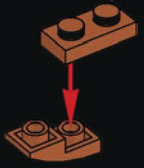

144



145

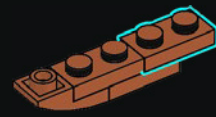

146

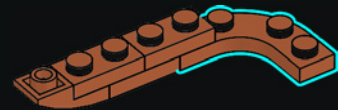

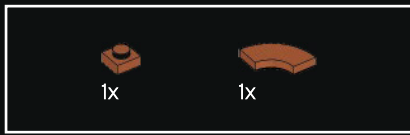

147

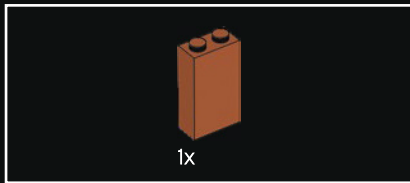
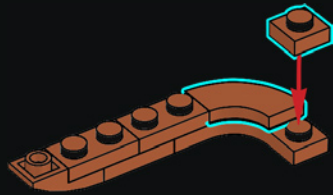

148

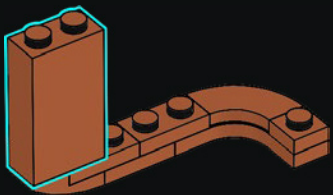

149

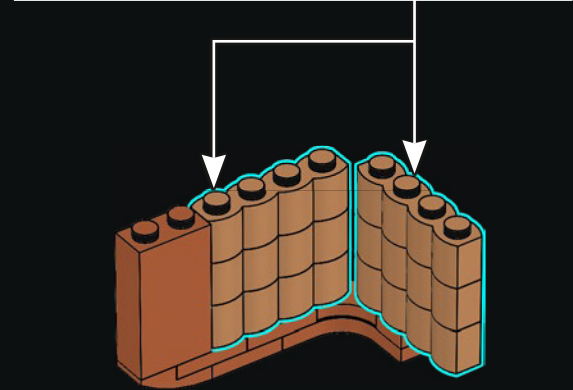
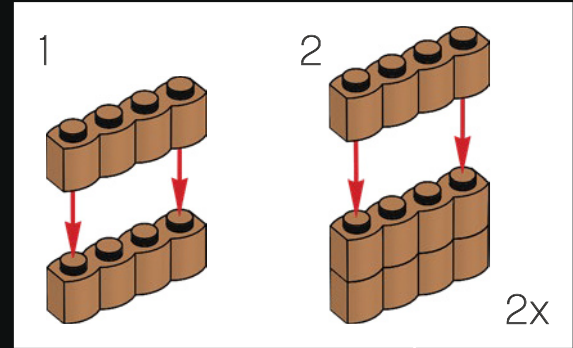



150

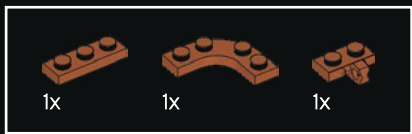
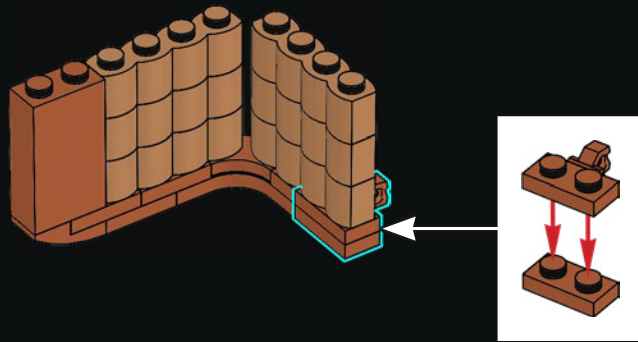

151

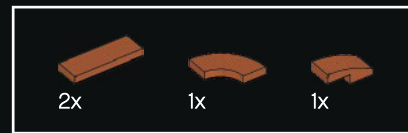
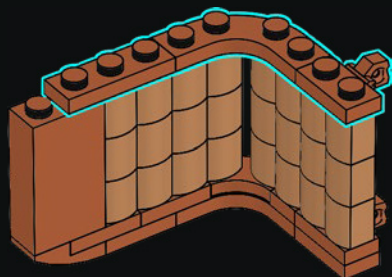

152

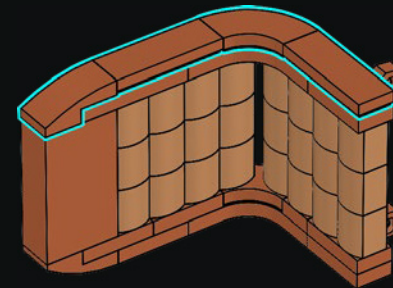

153

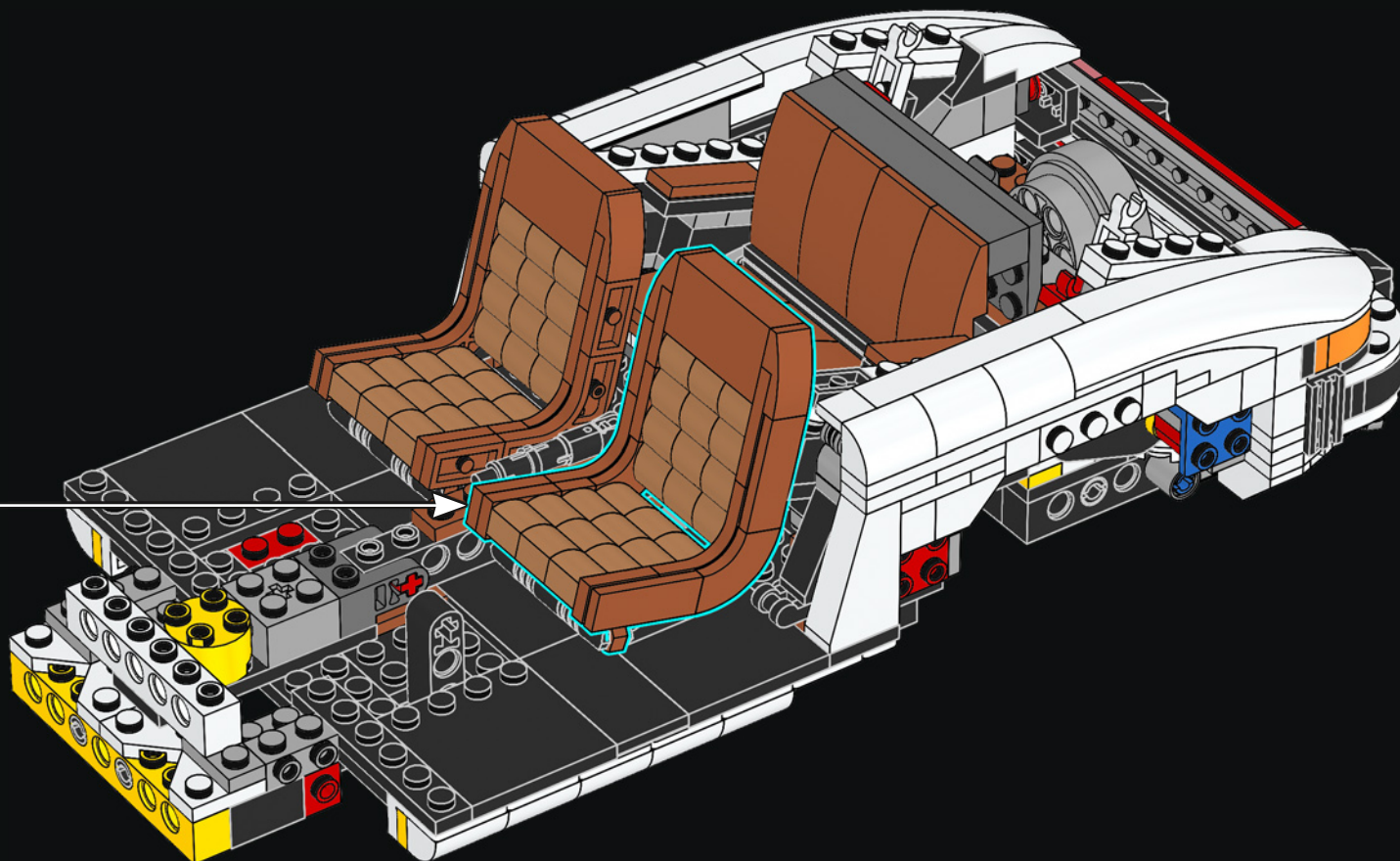

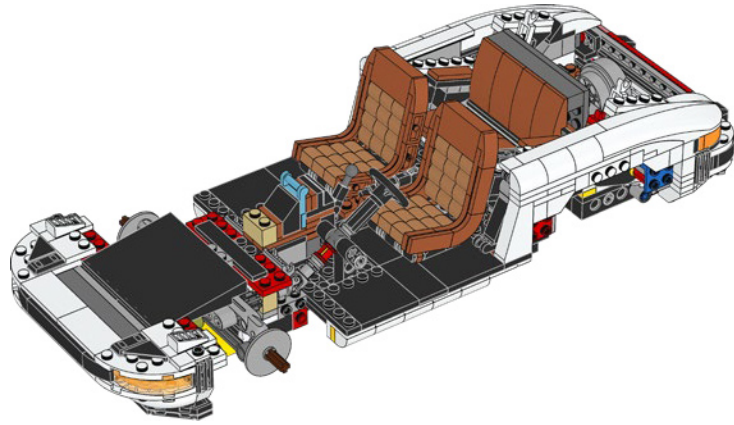



154

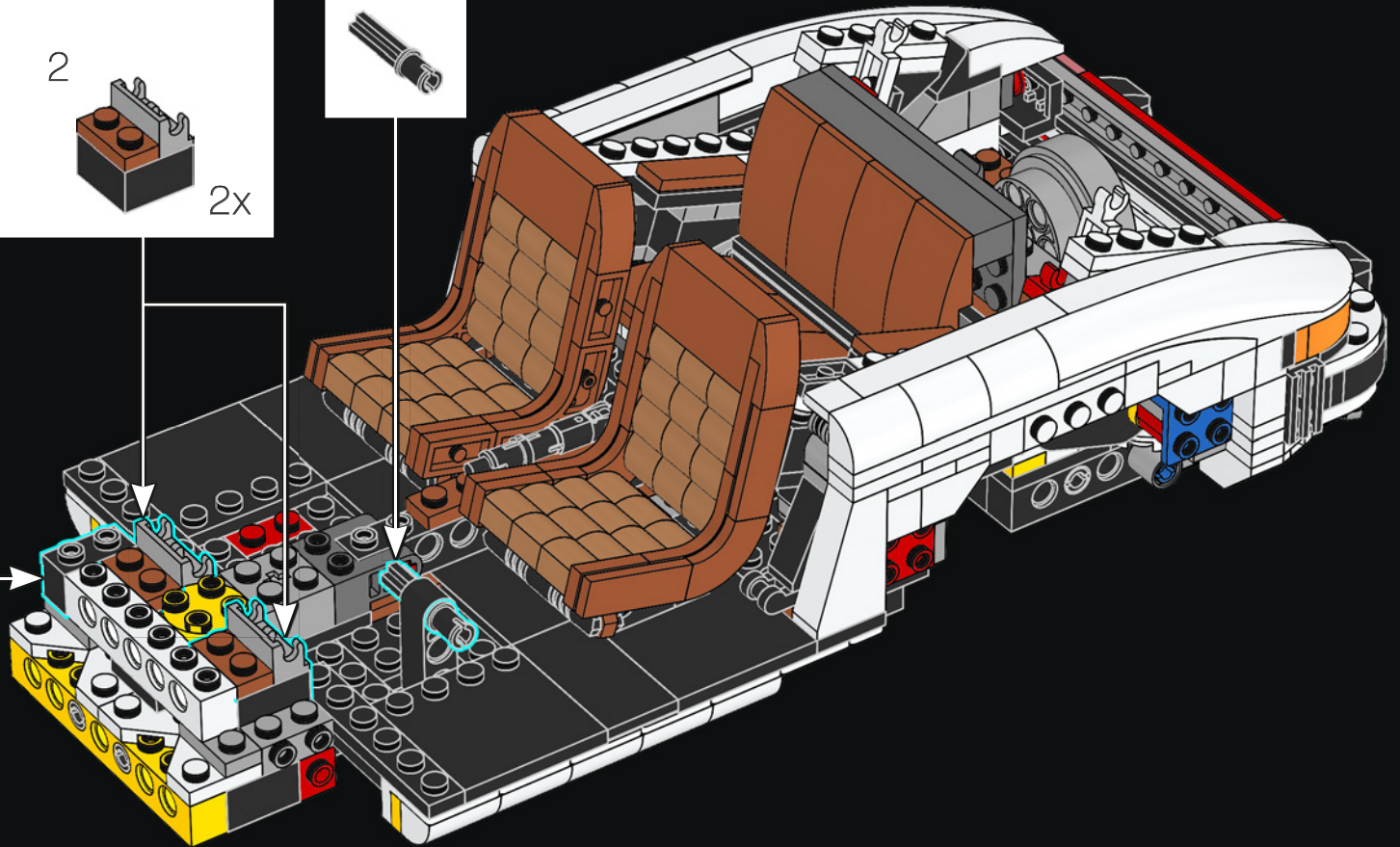
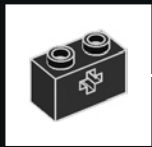
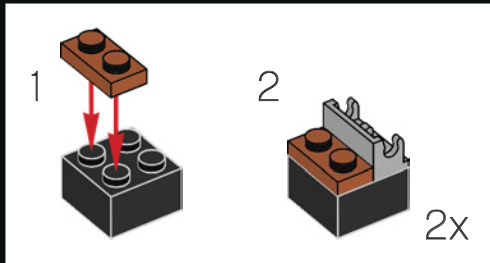

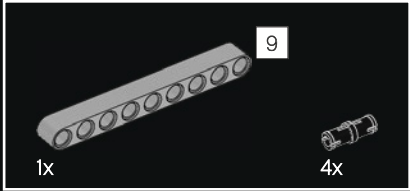
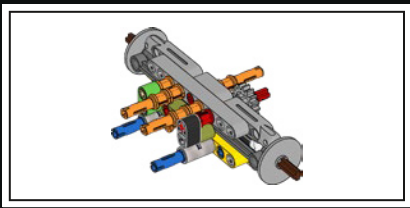

155

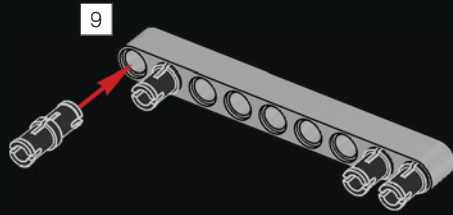

156

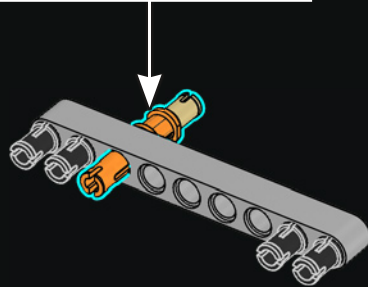
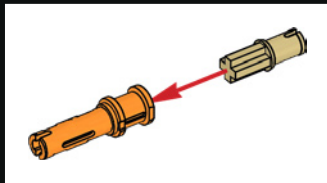

98



157

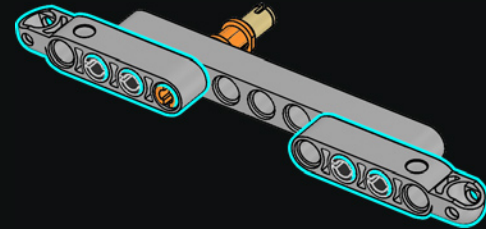
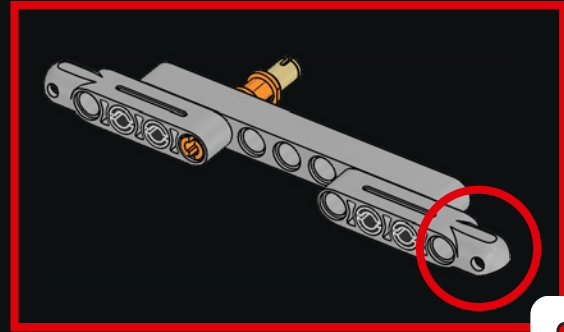

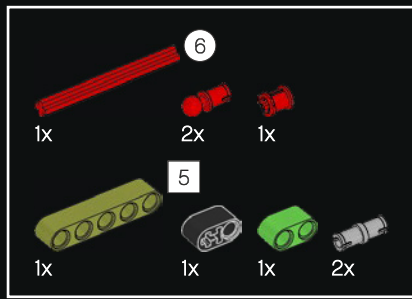

158

